

SELECTION AND USE OF TLDs FOR HIGH PRECISION NERVA SHIELDING MEASUREMENTS

H. C. Woodsum

Westinghouse Electric Corporation
Astronuclear Laboratory

An experimental evaluation of Thermoluminescent Dosimeters (TLDs) was performed in order to select high precision dosimeters for a study whose purpose is to measure gamma streaming through the coolant passages of a simulated flight type internal NERVA reactor shield. The criteria for selection of the dosimeters was that they should be reproducible within $\pm 2\%$ and some must have spatial resolution within ± 1.5 mm.

The experimental procedure was to expose batches of 50-100 CaF_2 and LiF chip, mini, and micro TLDs to ^{60}Co radiation by mounting these dosimeters on a rotating wheel (to minimize positional differences). ^{60}Co radiation was used since it approximates the average energy of the gammas entering the shield. The 30 Ci source was placed ~ 150 cm from an aluminum wheel 51.1 cm dia. by 0.079 cm thick on which dosimeters were taped. All TLDs had been annealed for 1 hour at 400°C followed by 17 hours at 80°C prior to exposure.

Reading of the TLD exposures was performed on a digital readout system. All dosimeter data was processed by the TLDEVAL code which calculates the mean, standard deviation, variance for each dosimeter and fractional standard deviation of the mean.

Based on this study, the CaF_2 chip TLDs are the most reproducible dosimeters with reproducibility generally within a few percent, but none of the TLDs tested met the reproducibility criterion of $\pm 2\%$. The microdosimeters were the least reproducible to the point of not being usable for measurements below several hundred rads. The dosimeters tested are linear with dose over the range of 1-180 rads within $\pm 10\%$ and fading of dosimeters after exposure was found to be negligible within the accuracy of the measurements. The non-reproducibility of ^7LiF mini TLDs is not presently understood, but may be due to a combination of the following: lack of sensitivity (compared to comparable CaF_2 dosimeters), non-radiation-induced thermoluminescence, or radiation damage from previous reactor irradiations. These effects are currently under further investigation.

Since the CaF_2 chip dosimeters appear to be the only ones which approach the requirements for the combination of reproducibility and spatial resolution, attempts will be made to further improve their precision by selective use of dosimeters based on repeated calibrations and control of the effects which are known to produce non-radiation-induced thermoluminescence.

INTRODUCTION

An experimental evaluation of Thermoluminescent Dosimeters (TLDs) was performed to select high precision dosimeters for a set of experiments whose purpose is to measure gamma ray streaming through the coolant passages of a simulated flight type internal NERVA* reactor shield. The criteria for selecting these dosimeters were based on experimental requirements for reproducibility within ± 2 percent and spatial resolution within ± 1.5 mm. The TLD selection study results will be presented, followed by the experiments which led to these requirements, and, finally, some preliminary experimental data from the shield streaming measurements will be given.

EVALUATION STUDY OF TLDs AND TLD CALIBRATIONS

General Description of TLD Evaluation Experiments

TLDs were selected for the initial phase of the gamma ray streaming experiments, since they are small enough to have the potential of meeting the spatial resolution requirements, and other investigators such as ANL⁽¹⁾ and ANSC⁽²⁾ have demonstrated their utility and accuracy for measurements of this type. TLDs are an integrating type of dosimeter, such as is needed with the source simulator used here, and considerable experience had been gained from their previous use. Several types of TLDs were available at the Westinghouse Astronuclear Experimental Facility

*The Nuclear Engine for Rocket Vehicle Application Program (NERVA) is administered by the Space Nuclear Systems Office, a joint office of the U. S. Atomic Energy Commission and the National Aeronautics and Space Administration. Aerojet Nuclear Systems Company as prime contractor for the engine system and Westinghouse Electric Corporation as sub-contractor for the nuclear subsystem, are developing a nuclear propulsion system for space application.

(WANEF) and a preliminary experimental investigation was conducted to help select TLDs which would meet the reproducibility requirements as well as the spatial resolution requirements. The reproducibility criteria and spatial resolution criteria were dictated by the following shield streaming measurement experimental requirements. 1) It was desirable to have a detector which was reproducible to within 2 percent since, for the smallest duct size (0.477 cm diameter) and the thinnest shield considered (15.2 cm), the maximum effect of duct streaming was expected to be of the order of a few percent increase over the no duct case. 2) Also, in order to be able to obtain suitable spatial resolution of the streaming patterns near the openings over the smallest duct(s), dosimeters should be ideally no larger than 1/2 to 1/3 of the duct width, or perhaps 1.5 mm. Generally, however, the smaller the dosimeter, the less sensitive it is, which, in turn, reduces the signal to "noise" ratio. Thus, there is a trade-off between the spatial resolution and reproducibility.

Types of TLDs available at WANEF for use in these experiments are shown in Table 1. In order to investigate the sensitivity and reproducibility of these dosimeters, a controlled experiment was set up.

Experimental Procedure for TLD Evaluation and Calibrations

A description of the experimental apparatus and setup for the TLD evaluation study will be presented. Batches of TLDs of the various types shown in Table 1 were exposed to ^{60}Co radiation by mounting these dosimeters on a rotating wheel (to minimize positional differences and maintain a constant radiation field on all dosimeters) placed near a fixed ^{60}Co source. The source-detector geometry is shown in Figure 1. The source used was a 30-Ci (on 9/67) ^{60}Co source capable of storage in a lead shield and remotely operable to the exposure position in a pit approximately 15' x 15' x 11-1/2' deep by the use of a manually operated, mobile gamma ray projector. The dose rate used for the calibration was taken from a calibration of the ^{60}Co source radiation field performed by use of a CO_2 -filled carbon-wall ionization chamber which was previously calibrated at NBS, as described in Reference 3. The dose rate was corrected to equivalent rads (carbon) by multiplying R values by 0.869 rads (C)/R. The value obtained was 10.49 rads (C)/hr at 1.5 meters on 7/1/70.

The wheel used in this study was made of aluminum sheet 0.079 cm thick and 51.1 cm in diameter. Dosimeters were taped directly to its face at a radius of 23 cm. The TLDs were located at approximately 1.5 meters from the source and were exposed in batches of 50-100 for approximately one hour, except for the dose linearity check which required a 6-minute and 18-hour as well as a 60-minute exposure under similar conditions.

A dosimeter decay investigation was also conducted to determine the relative fading characteristics for each of the dosimeter types. Each batch of 50 - 100 dosimeters was divided into 6 equal lots following one irradiation exposure of 1 hour and were read out at approximately 0, 1, 4, 8, 24, and 48 hours after irradiation. Because of schedule difficulties, not all dosimeters were able to be read out at 8 hours after irradiation. Also, when it was determined that the micro dosimeter variability was large enough to preclude their use for the streaming experiments, the originally planned decay study was dropped for the

TABLE 1.

TLD TYPES AND SIZES FOR USE IN STREAMING MEASUREMENTS

Types	Shape	Size	Material
TL-028B	Chip (thin)	1/8"x1/8"x0.03"	Li^6F
TL-028A	" (thick)	1/8"x1/8"x1/16"	Nat. LiF
TL-028C	" "	1/8"x1/8"x1/16"*	Li^7F
TL-22	Tubular (mini)	1.4 mm x 12 mm	Li^6F
TL-23	"	1.4 mm x 12 mm	Li^7F
TL-31	"	1.4 mm x 12 mm	CaF_2
TL-33	Chip (thick)	1/8"x1/8"x1/16"*	CaF_2
TL-29	Tubular (micro)	0.9 mm x 6.0 mm	LiF
TL-19	"	0.9 mm x 6.0 mm	CaF_2

*Also available in thin (0.03" thick) chip with same designation.

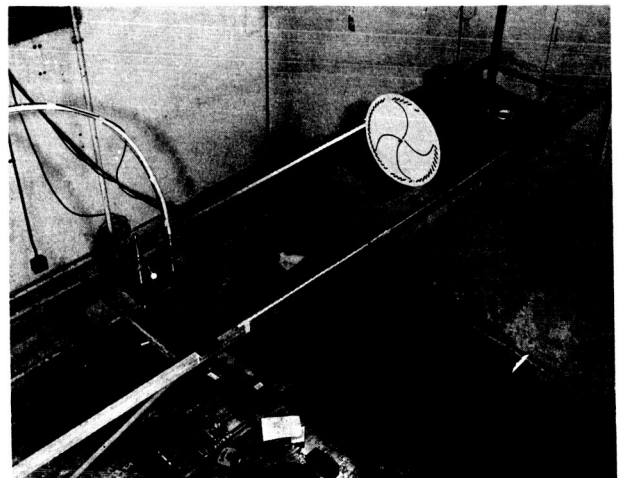

Figure 1. Experimental Configuration for TLD Evaluation Study

CaF₂ micro TLDs. The 18-hour irradiation for the LiF micro TLDs was also dropped for the same reason.

All TLDs were annealed for 1 hour at 400°C (750°F) followed by 17 hours at 80°C (176°F) in a Blue M. Co. Lab-Heat oven prior to exposure. Reading of the TLDs was performed on an EG&G Model TL-3B reader with digital readout. (Exceptions to the use of the digital reader are noted.)

All dosimeter data were processed by the TLDEVAL code which calculates the mean, standard deviation, variance for each dosimeter, and fractional standard deviation of the mean.

DISCUSSION OF RESULTS OF TLD EVALUATION STUDY

Reproducibility and Spatial Resolution

This study revealed that none of the dosimeters tested met both the reproducibility (+ 2 percent) and spatial resolution (+ 1.5 mm) criteria. The CaF₂ and LiF chip dosimeters, however, came the closest to meeting the reproducibility requirements with values ranging from + 3-6 percent (16). By very careful control and a better understanding of the non-random effects, it may be possible to achieve the + 2 percent criterion with these dosimeters. Based on the results of this preliminary study, however, thin (0.03" thick) ⁷LiF chip TLDs should be substituted for the thick chip ⁷LiF TLDs which were tested and reported here. This substitution is necessary since the thick chips give a spurious response on the digital reader for low doses and for less than 20 percent of full scale reading although the digital reader unit per se is more precise than the chart reading provided that the heater current is not too excessive. The use of thin chip LiF as well as CaF₂ TLDs, however, will necessitate the use of electron equilibrium producing material around each of these dosimeters since it has been demonstrated that their response will vary by perhaps as much as 30 percent, depending on whether the chip is placed directly on the aluminum shield or suspended slightly above it if "sufficient material" is not placed around it. "Sufficient material" for undegraded ⁶⁰Co radiation is approximately 380 mg/cm² or approximately 2/3 the range of 1.2 MeV electrons.

The LiF and CaF₂ mini dosimeters (type TL-23 and TL-31, respectively, in Table 1) are less reproducible than the chip type of TLDs. The precision for the CaF₂ type of dosimeter ranged from + 6 to 8 percent (16) although the size of these detectors is small enough that they could meet the + 0.15 cm spatial resolution requirement. The within-batch precision of the ⁷LiF mini TLDs was less than that of the CaF₂ minis being in the range of + 10 to 16 percent (16) and reproducibility between batches was as much as 50 percent. This between-batch variability in response of the ⁷LiF TLDs is not presently understood, but may be due to any or all of the following: sensitivity to light, sensitivity to mechanical vibrations, and radiation effects of the dosimeters from previous reactor irradiations which have been only partially annealed out by succeeding annealings and readouts. The within-batch variation is attributed largely to non-uniformity of both the contained powder and the glass containers which, by visual inspection, can be seen to be quite non-uniform. Also, the increased variability compared with the chip dosimeters is due to their decreased sensitivity. From Table 2, it can be seen that

TABLE 2
TLD EVALUATION STUDY FOR TIS-23 WITH 30 Ci ⁶⁰Co SOURCE
TLD READER RESPONSE, R/RAD

	LiF			CaF ₂		
	Chips (TL-22B)	Minis (TL-23)	Micros (TL-29)	Chips (TL-31)	Minis (TL-31)	Micros (TL-31)
1 Hr. Exposure	0.193 ± 4%	0.0605 ± 17.0%	4.78 × 10 ⁻³ ± 19.3%	1.07 ± 5.8%	0.396 ± 6.8%*	0.0238 ± 11.1%
6 min.	0.216 ± 3.6%*	0.0411 ± 16.1%	4.93 × 10 ⁻³ ± 25.1%	1.11 ± 3.9%	0.448 ± 6.4%	0.0702 ± 23.28%
60 min.	0.189 ± 3.7%	0.0377 ± 9.7%	3.61 × 10 ⁻³ ± 12.9%	1.05 ± 3.2%	0.409 ± 7.5%	0.0357 ± 8.21%
18 Hr.	0.200 ± 2%	0.0444 ± 8.6%	...*	1.01 ± 4.7%	0.408 ± 6.3%	0.0379 ± 12.72%
1 Hr. Exposure Read At 0	0.191 ± 0.28%	0.0532 ± 9.0%	8.42 × 10 ⁻³ ± 22.9%	1.09 ± 4.2%	0.420 ± 5.3%	...*
1 Hr.	0.160 ± 6.8%	0.0476 ± 5.1%	8.17 × 10 ⁻³ ± 25.0%	1.04 ± 4.4%	0.371 ± 6.1%	...*
4 Hr.	0.185 ± 2.1%	0.0489 ± 18.2%	10.5 × 10 ⁻³ ± 9.8%	1.03 ± 3.1%	0.402 ± 2.3%	...*
8 Hr.	0.176 ± 4.6%	0.0517 ± 8.6%	...*	...*	...*	...*
24 Hr.	0.176 ± 4.7%	0.0526 ± 11.2%	9.24 × 10 ⁻³ ± 11.0%	1.08 ± 5.1%	0.400 ± 5.2%	...*
48 Hr.	0.187 ± 1.0%	0.0557 ± 13.9%	11.8 × 10 ⁻³ ± 38.5%	0.896 ± 5.3%	0.364 ± 11.0%	...*

*Read from chart.
**Not performed for reasons given in text.

these dosimeters are approximately a factor of 4-5 less sensitive than the LiF chip TLDs and a factor of 20-25 less sensitive than the CaF₂ chip TLDs.

The micro TLDs, while having even better spatial resolution than the mini TLDs, show even more variability and lack of precision with the within-batch variability being from 13-25 percent (16) for the LiF micros and from 8-23 percent (16) for the CaF₂ micros. The sensitivity of these dosimeters is about 50 times less than the comparable chip dosimeters. The repeatability in this case is even worse than that of the LiF minis, varying as much as a factor of 2 for between-batch irradiations. The within-batch variability is attributed to the same causes as for the mini TLDs. Since these dosimeters are even smaller and less sensitive, as expected, their non-uniformity produced variations have a larger effect. The large batch-to-batch variations are, as in the case of LiF mini TLDs, not understood. For these reasons, it is recommended that these dosimeters not be used for any precise experiment where the expected dose does not exceed ~1000 rads.

Decay Effects

Results of the dosimeter decay investigation study showed negligible fading or decay of dosimeter response from 4-48 hours after exposure, except for CaF₂ dosimeters where a 10-20 percent decrease from 24-48 hours was noted.

Light Exposure Effects

Some checks on light-produced effects were made for the chip dosimeters, which were the most reproducible obtained in this study. Specifically, an auxiliary experiment was conducted where 5 CaF₂ TLDs were exposed to fluorescent light both during and after source exposure and 5 CaF₂ chip dosimeters were covered so that light could not reach them, and a sizable difference was observed. For this case, it was noted that the TLDs which were not exposed to light read a factor of 2 higher than those exposed to light. A similar experiment with LiF TLDs showed no such effect. Thus, exposure to light is most certainly an important effect for CaF₂ TLDs.

Based on these TLD evaluation study results, the chip type dosimeters were selected for the first phase measurements of shield streaming which are described next. Since few thin chip LiF TLDs were available when these experiments were initiated, TL-033 thin CaF₂ chip dosimeters were utilized.

DESCRIPTION OF GAMMA RAY SHIELD STREAMING EXPERIMENTS

Description of Experimental Equipment and Procedures

Measurements of the gamma ray streaming through penetrations in an aluminum shield mockup using a simulated plane isotropic source of ⁶⁰Co radiation was undertaken in order to determine the importance of gamma ray streaming through coolant penetrations in the internal BATH shield of a flight type R-1 NERVA reactor. A ⁶⁰Co source was chosen for this study since its nearly monoenergetic 1.25 MeV gamma ray energy approximates the average energy of gamma rays emitted from the NERVA reactor core. Aluminum was chosen for the shield mockup material since its density and gamma ray attenuation properties closely simulate the Boron Carbide-Aluminum-Titanium Hydride (BATH) internal flight shield which is composed of 70 percent by volume aluminum.

A 40.6 cm diameter, uniform, isotropic disk source of ⁶⁰Co radiation was simulated by means of a mechanical source traversing system shown in Figure 2. This mechanism moves a small source back and forth across a circular area 40.6 cm in diameter. The construction of this simulator and the analytical and experimental checks to assure that this simulator system met the source uniformity criteria of + 2 percent between areas of 0.01 cm² will be the subject of a later paper and thus will not be discussed here. A sketch of the overall experimental geometry for the shield streaming measurements is shown in Figure 3. The shield mockup geometry is illustrated in Figure 4.

Finally, Figure 5 is a photograph of the overall assembled experimental apparatus with the shield mockup slabs and plugs in place. Duct diameters of 0.477 and 2.8 cm were investigated in the first phase of this experiment.

Aluminum boxes, as shown in Figure 6, were specially made to assure electron equilibrium in the CaF₂ chip TLDs. The boxes containing TLDs were then mounted directly on top of the shield configuration which was previously shown in Figures 2 - 4 and were exposed for one complete cycle of source traverse (~34 minutes) with the ducts plugged and with a 2.8 cm diameter duct unplugged. The results of these measurements are shown in Figure 7.

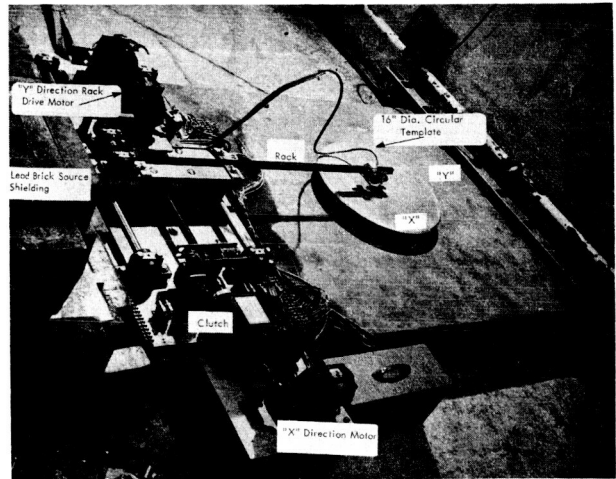
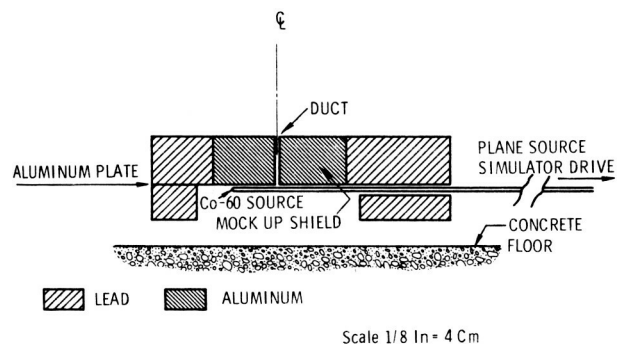
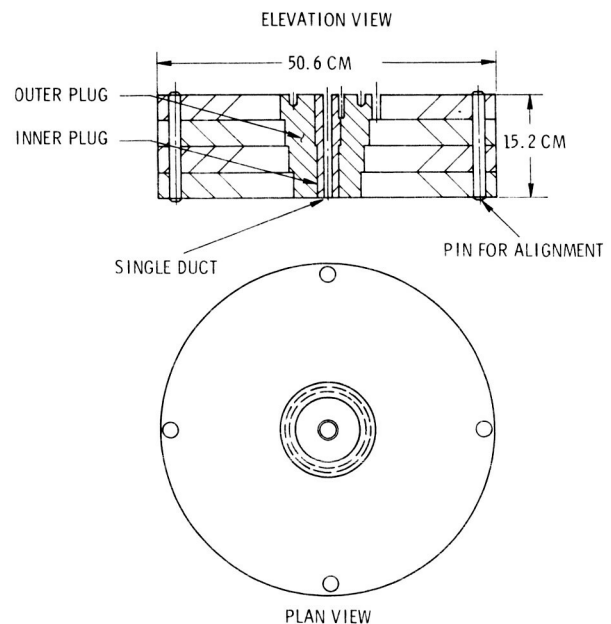

Figure 2. Plane Source Simulator Traversing System



613503-1B

Figure 3. Sketch of Shield Streaming Experiment



613503-2B

Figure 4. Shield Mockup Geometry for Shield Streaming Experiments



Figure 5. Assembled Shield Mockups for 2.8 cm Duct Configuration with TLDs in Place

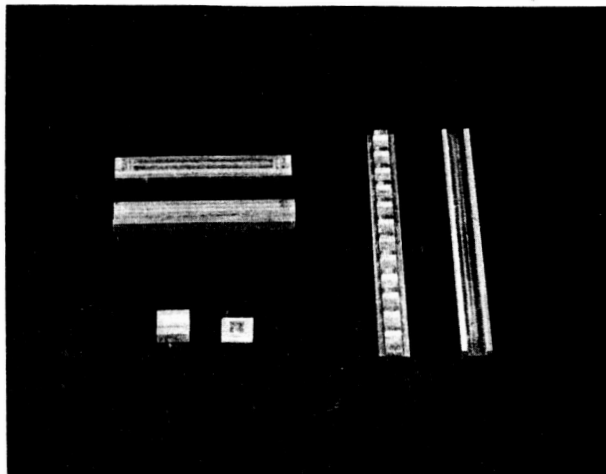

Figure 6. View of Disassembled Aluminum Boxes Made to Contain CaF_2 TLDs

required, and preliminary measurements were completed for a 2.8 cm diameter duct in 15.2 cm thick aluminum and for a 0.437 cm diameter duct in 19.0 cm thick aluminum. Based on these results, further experimental work is required to 1) more closely approach the spatial and precision requirements and 2) to resolve differences between measurements and predictions.

Results of Shield Streaming Measurements

The ratio of the measurements unplugged/plugged shows the relative streaming effect and radial distribution of the streaming. The results of the initial measurements for the 2.8 cm diameter duct indicates a ratio of about 1.40 whereas a preliminary estimate of the ratio of 1.20 was obtained based on simple line-of-sight considerations. However, more rigorous analysis, which included scattering effects, indicated that the increased ratio was probably due to floor-scattering effects and the enhanced low energy response effect of the CaF_2 dosimeters. Thus, a 0.07-inch thickness of lead was added immediately below the shield mockup and the experiment was redone. Results of this second experiment agree well with the predictions (see Figure 7). Similar measurements conducted with a 0.477 cm diameter duct in a 19.0 cm thick aluminum shield mockup showed no peaking over the duct within the accuracy of the measurements.

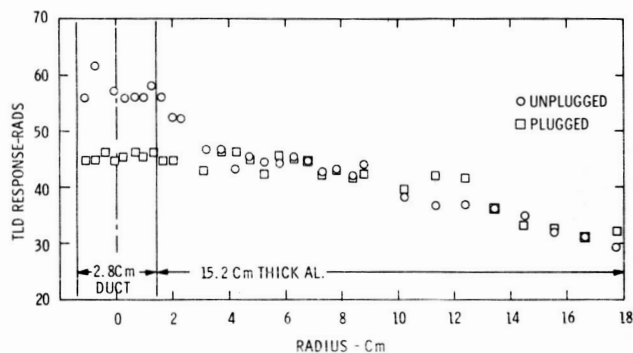

Figure 7. CaF_2 TLD Measurements on Plugged and Unplugged 2.8 cm diameter Hole in 15.2 cm Aluminum

CONCLUSIONS

An experimental evaluation of available TLDs was conducted in order to help select TLDs which would meet experimental shield streaming measurement requirements of $\pm 2\%$ reproducibility and ± 1.5 mm spatial resolution. Although none of the dosimeters met both of the above criteria, LiF and CaF_2 chip dosimeters approached the reproducibility requirements (with $\pm 3-6\%$) and were about twice the spatial resolution requirements (with 3.2 mm). Thus, CaF_2 chip (rather than LiF chip dosimeters) were selected for the initial phase of shield streaming measurements because of their availability in the quantity

REFERENCES

1. ANS Transactions, Vol. 10, No. 1, 1967 Annual Meeting, San Diego, Calif., June 11-15, 1967, p. 395, "TLD Measurement of Gamma-Ray Heating with AARR Critical Assembly," G. S. Stanford, T. W. Johnson.
2. AGC-RN-S-0510, "XE-Prime Engine Final Report," Vol. III, Book 1, Test Analysis, May 1970.
3. WANL-PR(LL)-022, "Synthesis of Computational Methods for the Design and Analysis of Radiation Shields for Nuclear Rocket Systems, Vol. 1, Radiation Measurements in a Nuclear Rocket Propellant Tank Mockup Using Simulated Liquid Hydrogen," Sept. 30, 1968.