

THE EXTERNAL GAMMA RADIATION ENVIRONMENT FROM THE KIWI,
PHOEBUS, AND PEWEE REACTORS*

RICHARD E. MALENFANT

Los Alamos Scientific Laboratory
Los Alamos, New Mexico

During the past few years, ground tests of high-powered propulsion-prototype reactors by the Los Alamos Scientific Laboratory have provided several opportunities to observe the external radiation environment. Although the data may not be directly applicable to the evaluation of radiation levels for flight systems, they do provide an extensive set of results for comparison with calculations on systems similar to those which may be flown. In addition, the experience with reactor radiation fields covering square miles is considered unique. Reactor tests have been conducted in free air (the Kiwi B4D and B4E reactors) and inside of open well shields (the Phoebus 1-B, Phoebus 2-A, and Pewee 1 reactors). Measurements were taken over distances ranging from contact with the pressure vessel out to greater than 5000' both during operation and after shutdown. Separate assessments of the effects of direct beam, scatter, capture, and activation were attempted. Some measurements characteristic of each of the systems named will be presented and compared with results of calculations.

Measurements of the external radiation levels on early Rover reactor tests provided empirical information on the distribution of leakage radiation, variation of radiation levels with distance, and the shielding effects of various structures (refs. 1,2). The information was essential to provide the background for the design of further facilities to support the reactor tests, particularly in view of the complexity of the test site areas. Concurrently, techniques for analytical evaluation were being developed and applied. A comparison of some measurements on Kiwi B1A (1962) and some point-kernal calculations made by D. M. Peterson (ref. 3) for

core sources only are given in figures 1 and 2. The dose points were located on an arc 127 cm in radius centered at the reactor midpoint. Energy release for the integral measurements was taken to be ~ 90 MW-sec (2.95×10^{18} fissions). Agreement between calculated and measured values close to operating Kiwi size reactors has always been good. Deviations between calculated and measured gamma ray values at small angles ($<50^\circ$) are attributed to external scattering and to capture gamma rays from the privy roof shield shown on figure 1 below the reactor.

As the design of the reactors improved with experience, power levels and

* Work performed under the auspices of the U.S. Atomic Energy Commission.

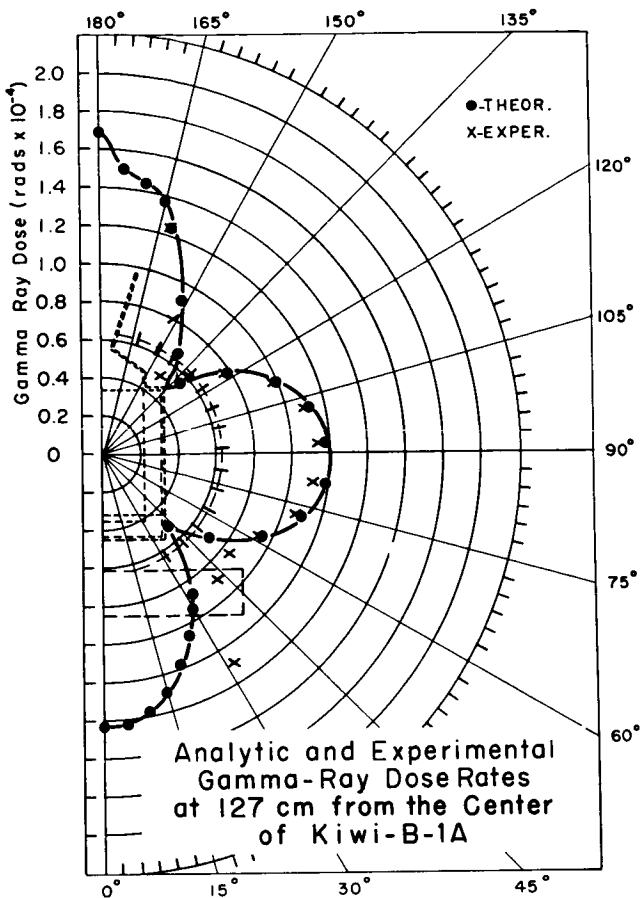

Figure 1

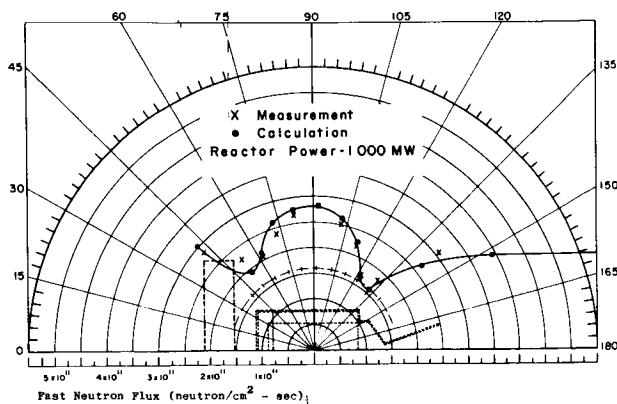

Figure 2

integrated energy releases increased. It became apparent that shielding would be required to reduce area activation and protect the structure of the test complex. Extensive measurements of operational and post-shutdown radiation levels were made during the Kiwi B4D and B4E test series (refs. 4,5,6,7) with at least one objective being the acquisition of information to design a facility shield. This was necessary because the radiation levels due to activation were fairly large (figures 3 and 4, from ref. 4), so that there would be residual radiation problems after removal of the reactor from the area where there had been high powered runs. At some decay times, radiation from activation was comparable to that from the decaying reactor.

In the radiation field arising from the decay of mixed fission products (following a $t^{-1.2}$ type law) and a few intense activation species (following $e^{-\lambda t}$ decays), there is a maximum relative contribution to the total dose from the activation product at a time equal to ~ 1.7 half lives. Test site soil, asphalt, and concrete indicated decay characteristics with half-life groups near 2.5 hours, 15 hours, and 30 days. This behavior helped to distinguish between activation and contamination, even in an area illuminated by the decaying reactor.

Measurements of dose rate as a function of distance away from a shutdown reactor, as well as calculations of the operational and shutdown cases, indicated gamma ray equivalent mean-free-paths of approximately 600' (figure 5, ref. 4). Earlier measurements on operating reactors indicated a value of 1300 feet (e.g., ref. 1, p. 17). The difference has been attributed to gamma rays arising from air capture which are more penetrating than gammas associated with fission or those resulting from the decay of mixed fission products.

Following the extensive field studies and numerous calculations, the Phoebus 1 facility shield was designed and built. It was expected that radiation energy deposition in the shield, a cylindrical annulus of borated water and aluminum, would amount to 9.8 MW per 1000 MW of reactor power. Measurements at a reactor power of 1460 MW indicated an energy deposition of ~ 15.6 MW. Details of the shield, design and analysis of its behavior have been presented by Graves (ref. 8) and Malenfant (ref. 9).

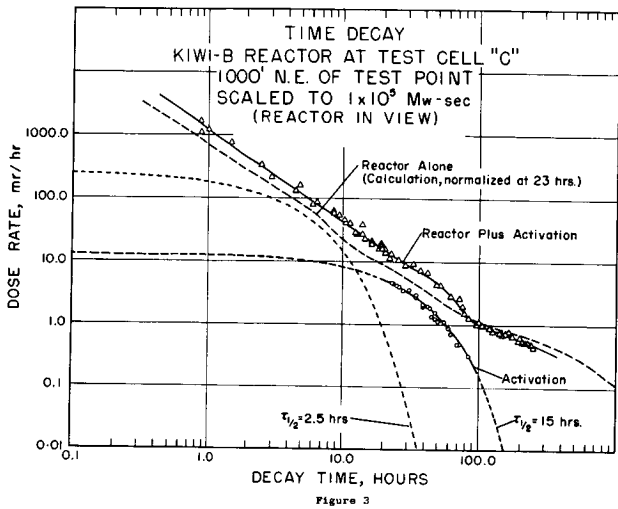

Figure 3

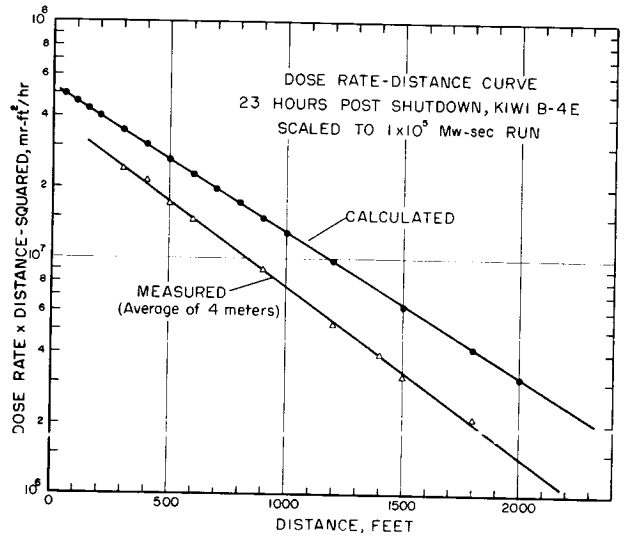

Figure 5

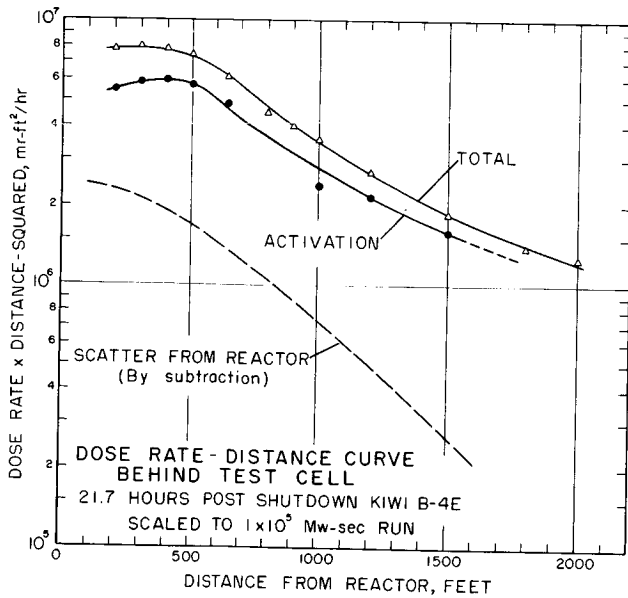

Figure 4

The Phoebus 1-B reactor was unique in many respects:

1. It was the first Rover reactor to be tested inside of a shield.
2. The Phoebus 1-B provided the most severe external radiation environment of all Rover reactors tested.
3. External radiation analysis was more extensive than that for any other LASL Rover reactor.

Phoebus 1-B was a solid core heat exchanger propulsion prototype reactor employing a uranium-graphite core 35-inches in diameter and 52-inches long. A cross-section of the reactor including characteristic dimensions is given on figure 6 (ref. 8). A model employed for various calculations is shown in figure 7 and details of its composition are provided on table 1.

Table 1

Elemental Densities and Compositions for the Reactor Mockup

Material Region	Elemental Densities (g/cm ³)										Total Density (g/cm ³)
	U	C	Be	Al	Nb	Fe	H	O	Na	B	
1	.214	1.234	-	-	.136	.037	-	-	-	-	1.621
2	-	1.488	-	-	-	-	.002	-	-	-	1.490
3	-	-	1.656	-	-	-	.011	-	-	-	1.667
4	-	-	-	2.700	-	-	-	-	-	-	2.700
5	-	-	-	-	-	-	.008	-	-	-	0.008
6	-	-	-	1.626	-	.333	.003	-	-	-	1.962
7	-	1.091	-	-	.776	.036	-	-	-	-	1.903
8	-	-	-	-	-	4.000	-	-	-	-	4.000
9	-	-	-	-	-	1.180	-	-	-	-	1.180
Shield borated water:	-	-	-	-	-	-	.107	.907	.010	.020	1.044
Privy roof borated water and steel balls:	-	-	-	-	-	4.800	.043	.363	.004	.008	5.218

Shield borated water:

Privy roof borated water and steel balls:

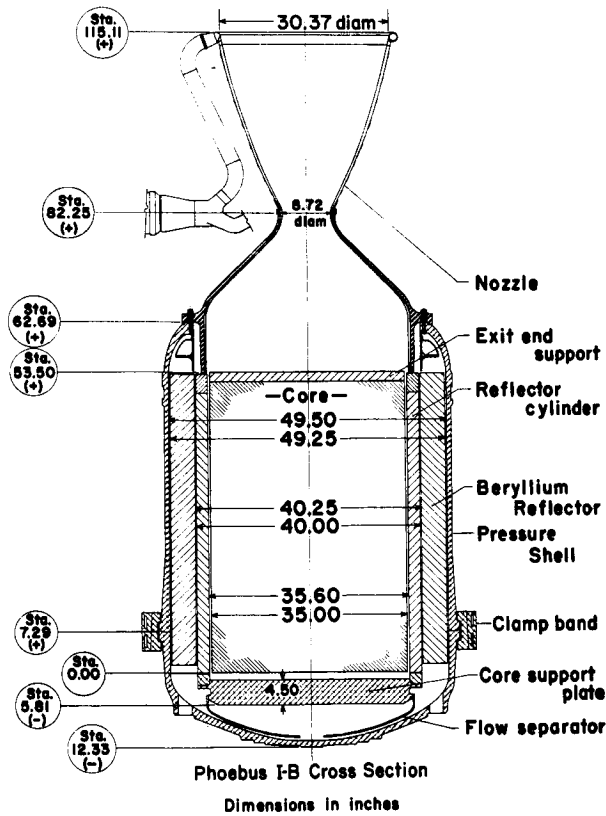
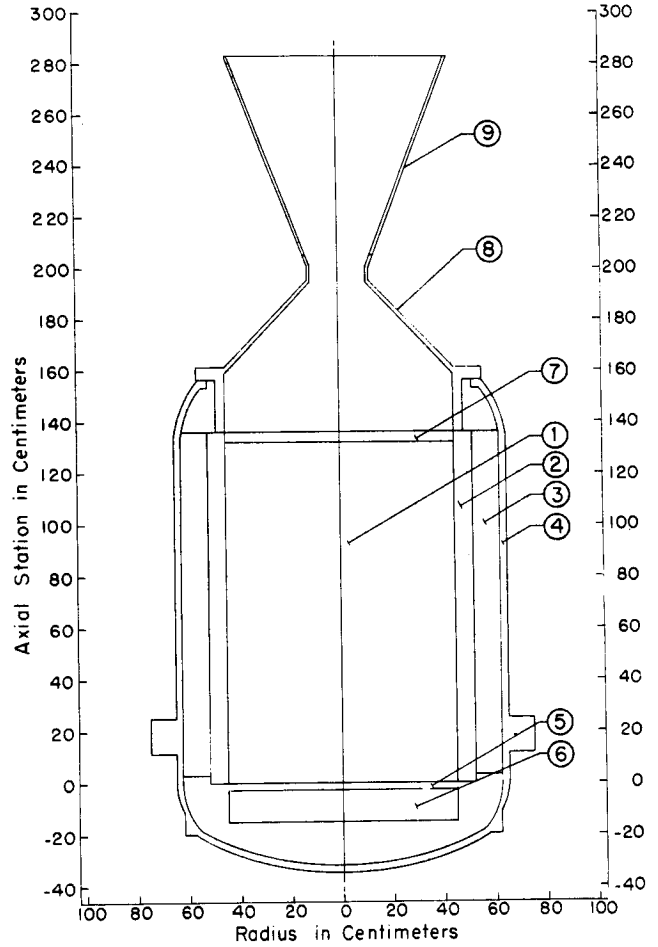

Figure 6



Phoebus I-B Calculational Model

Figure 7

Figure 8 indicates the relationship of the reactor to the shield, a schematic of the shield's internal arrangement, the location of the one-inch thick supporting girdle outside the shield, and the locations of some points where detailed calculations were made for comparison with measurements. Results are indicated on table 2. (Locations on this, and subsequent tables, references the radial dimension to the core centerline and the axial dimension to the end of the fuel region near the pressure vessel dome. The positive z direction is toward the nozzle.) The analysis was performed using Monte Carlo to determine the magnitude of capture gamma sources (ref. 10), neutron transport to partition the sources among various species, and QAD point-kernal (ref. 11) calculations to determine the net effect. The calculated total values are generally within 20% of the measurements. An additional comparison between measurement and calculation is given on the shield traverse on figure 9 (ref. 8). Many additional measurements are presented in references 12 and 13.

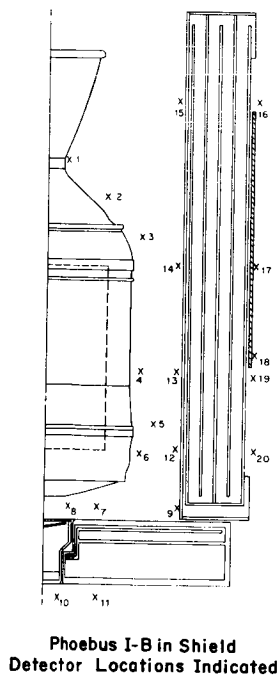
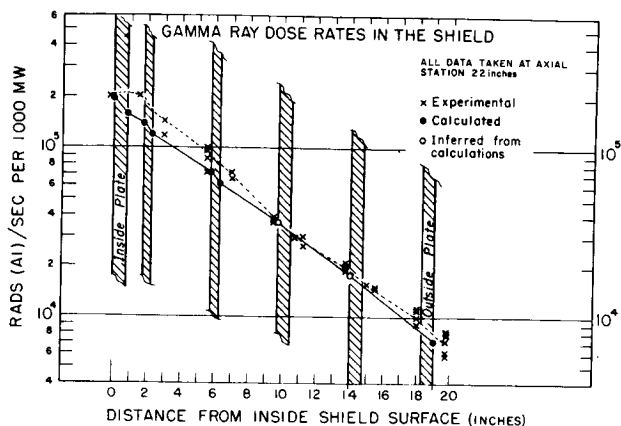

Figure 8



During the B4D and B4E tests, calculations and measurements had indicated the importance of external capture and scatter gamma rays (from the ground, test cell structures, etc.) to the dose rates under the privy roof shield. (The reactor is mounted in an upfiring position on a test car. Control rod actuators and other equipment are located in a room, the privy, under the reactor. The privy roof is a 9-foot square, 19-inch thick, shield of aluminum plates, borated water, and steel balls. The walls of the room are thin-gauge aluminum offering little shielding.) It was expected that the sides of the well shield would increase the apparent attenuation of the privy roof shield by about a factor-of-four by effectively eliminating the capture and scatter sources. Expectations were met, and the quite favorable comparisons obtained between measurement and point-kernal calculation for this location are shown in figures 10 and 11.

Table 2

Phoebus 1-B

Results of Calculations and Measurements

Location No.	Location, cm		Core Gamma Rads/MW-sec	Calculation		Measurement Rads/MW-sec
	r	z		Capture Gamma Rads/MW-sec	Total Gamma Rads/MW-sec	
1	16.5	203.9	*1.31/2	6.90/0	1.38/2	1.74/2
2	43.2	177.2	1.58/2	7.93/0	1.66/2	1.82/2
3	68.6	131.4	1.23/2	2.24/1	1.45/2	1.46/2
4	68.6	55.7	3.69/2	2.67/1	3.96/2	4.42/2
5	77.5	19.0	1.07/2	3.32/1	1.40/2	1.73/2
6	68.6	- 0.7	1.41/2	8.59/1	2.27/2	1.95/2
7	39.4	-39.1	1.79/2	5.32/1	2.32/2	1.63/2
8	8.3	-39.1	2.67/2	1.40/2	4.07/2	2.16/2
9	99.3	-39.1	6.69/1	3.17/1	9.86/1	9.46/1
10	10.2	-102.9	1.54/-1	4.75/-1	6.29/-1	
11	39.4	-102.9	2.04/-1	2.50/-1	4.54/-1	4.19/-1
12	95.1	1.7	9.39/1	2.78/1	1.22/2	1.44/2
13	95.1	56.0	2.14/2	3.53/1	2.49/2	3.05/2
14	95.1	132.2	9.03/1	2.40/1	1.14/2	1.67/2
15	95.1	244.9	2.80/1	1.02/1	3.82/1	5.83/1
16	158.9	244.6	5.72/-1	1.82/-1	7.54/-1	8.78/-1
17	161.4	131.9	1.90/0	2.57/-1	2.16/0	2.54/0
18	161.4	68.6	3.34/0	3.91/-1	3.73/0	4.63/0
19	158.9	51.6	6.53/0	8.59/-1	7.39/0	7.14/0
20	158.9	.9	4.02/0	6.78/-1	4.70/0	4.78/0

* Read 1.31/2 as 1.31×10^2 .

Phoebus 2-A, with a design power level of 5000 MW, was tested shortly after Phoebus 1-B. This reactor also employed a uranium-graphite core, but one 50" in diameter and 52" long. The reflector was a beryllium cylindrical annulus 8" thick (compare with 4.5" thick for Phoebus 1 and Kiwi). A schematic of the reactor in its shield is given on figure 12 (dimensions in cm). The reactor presented calculational problems in that capture gamma rays produced outside the core assumed a greater importance relative to core gammas. A limited set of measurements made in the annular space between the reactor and shield is compared with predictions in table 3. As Phoebus 2 was the only reactor of its kind to be tested, no extensive calculations of its gamma ray environment have been made for comparison with measurements.

The Pewee reactor was designed as a fuel test device. With a power density like Phoebus 2 but 1/10 of the core volume, design power was ~ 500 MW. Core length of 52" was maintained but the core diameter was reduced to ~ 18.1 ". In order to achieve criticality and control, a 8" thick beryllium reflector was required. Like Phoebus 2, capture gamma rays were expected to be more important (relative to core gammas) than in Kiwi or Phoebus 1 type systems, again because the thick reflector attenuates core gammas at the same time that it increases neutron thermalization. A cross-section of Pewee and the location of some points of measurement are indicated on figure 13. A comparison of the calculated and measured values from an early run are given on table 4. The agreement is reasonable.

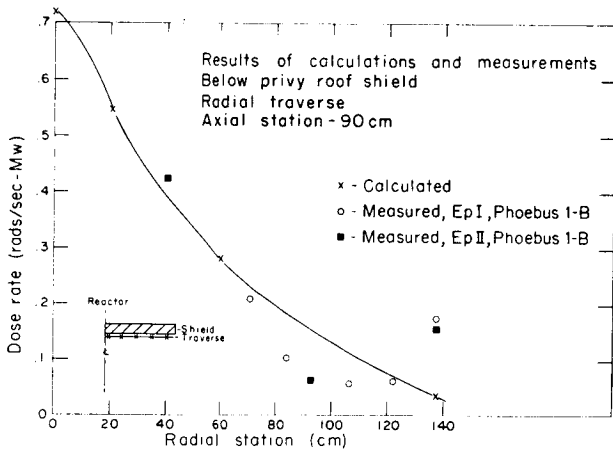

Figure 10

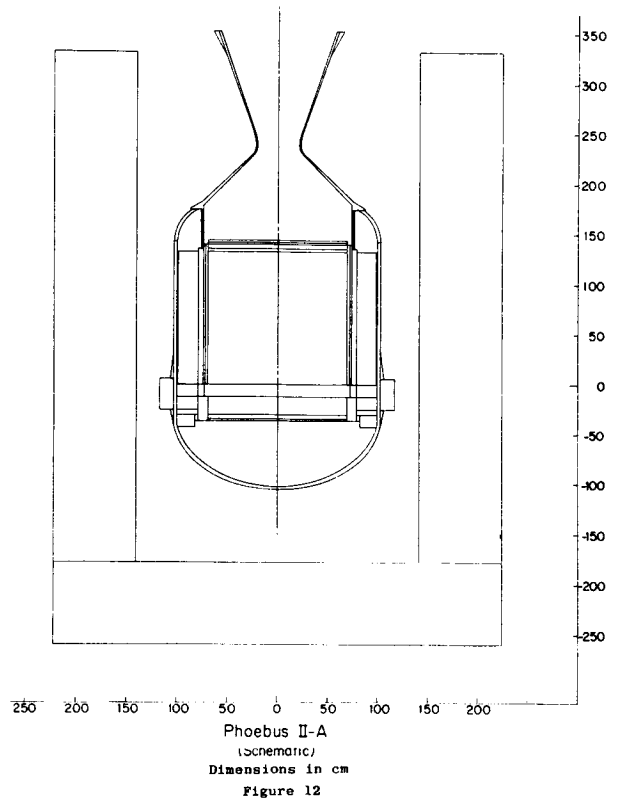

Figure 12

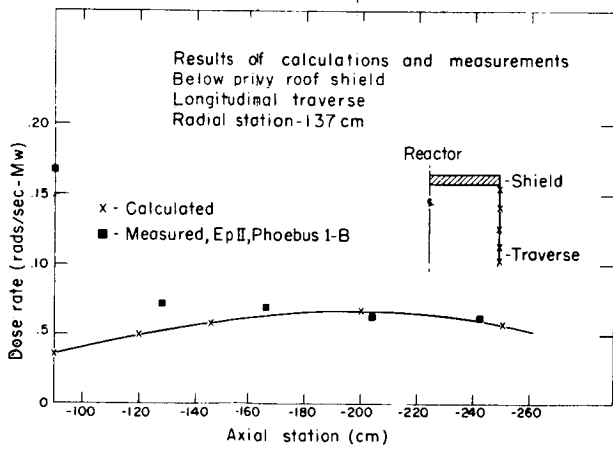

Figure 11

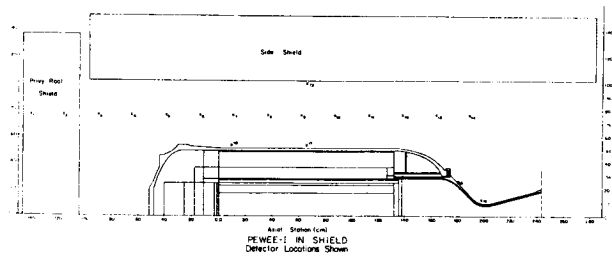

Figure 13

Table 3

A Comparison of Calculation and Measurement on Phoebus 2

Location (cm)		Calculation rads/sec @ 5000 MW	*Measurement rads/sec @ 5000 MW
r	z		
107.7	127.0	** 2.2/5	4.0/5
107.7	61.0	4.4/5	7.1/5
110.0	5.1	2.4/5	4.0/5
121.2	-15.2	1.5/5	1.8/5
104.1	-58.4	2.7/5	2.2/5

* The dose rate at 5000 MW was inferred by extrapolating from passive dosimeters exposed on an early experimental operation with an energy release of ~ 32.6 MW-sec and no hydrogen flow.

** Read 2.2/5 as 2.2×10^5 .

Table 5

Calculated and Measured Gamma Doses, Pewee, Post EP II
~ 3 Hour Exposure ~ 4 Days Post Shutdowns

Location	Station, cm	All Values are Tissue Rads		Deviation $\frac{\text{Calculated}-\text{Meas.}}{\text{Measured}} \times 100$
		Calculation	Measured	
		r	z	
1	76.2	-141.0	1.47	<15
2	76.2	-115.6	297.	107
3	76.2	-90.1	625.	488
4	76.2	-64.8	888.	888
5	76.2	-39.4	2486.	1060
6	76.2	-14.0	3148.	1900
7	76.2	11.4	5425.	3470
8	76.2	36.8	8006.	5170
9	76.2	62.2	9015.	6370
10	76.2	87.6	8131.	4980
11	76.2	113.0	5679.	3110
12	76.2	138.4	3468.	1630
13	76.2	163.8	2498.	1090
14	76.2	189.2	1879.	888

Table 4

Calculated and Measured Gamma Doses, Pewee, EP I
All Values are Tissue Rads for 6.73 MW sec

Location Number	Station, cm		Calculation			Measured	Deviation $\frac{\text{Calculated}-\text{Meas.}}{\text{Measured}} \times 100$
	r	z	Core y	Capture y	Total y		
1	76.2	-141.0	1.90	81	7.3	<15	
2	76.2	-115.6	89.2	18.0	107	100	+ 7.0%
3	76.2	-90.1	171.	34.1	205	320	-35.9%
4	76.2	-64.8	222.	54.8	287	410	-30.0%
5	76.2	-39.4	531.	102.	633	500	+26.6%
6	76.2	-14.0	832.	192.	1024	870	+17.7%
7	76.2	11.4	1285.	328.	1613	1300	+24.1%
8	76.2	36.8	1840.	441.	2281	1900	+20.1%
9	76.2	62.2	2035.	470.	2505	2200	+15.1%
10	76.2	87.6	1860.	412.	2272	2000	+13.6%
11	76.2	113.0	1319.	292.	1611	1400	+15.1%
12	76.2	138.4	745.	166.	910	840	+ 8.2%
13	76.2	163.8	453.	89.6	543	610	-11.0%
14	76.2	189.2	299.	53.3	352	430	-18.1%
15	12.7	198.1	724.	48.	772	700	+10.3%
16	26.2	180.1	651.	41.	692	680	+ 4.8%
17	53.8	66.0	3342.	814.	4157	3500	+21.6%
18	53.8	10.2	1847.	556.	2403	2200	+ 9.2%
19	99.8	66.0	1315.	270.	1585	1600	- 0.9%

Measurements of fission product decay gammas were made at the same locations following the second experimental plan of operation, EP II. Detectors were exposed for a timed period for comparison with calculation. Gamma ray source strengths for the comparison calculation were taken from reference 13. Results are compared in table 5. The lack of agreement is not understood.

A thumbnail summary of the external unshielded gamma radiation environment from Phoebus 1/Kiwi B, Phoebus 2, and Pewee is given in table 6.

Table 6

A Comparison Between Phoebus 1, Phoebus 2, and Pewee

Parameters	Phoebus 1	Phoebus 2	Pewee
Characteristic Power Level	1500 MW	5000 MW	500 MW
Dose Rate, Contact with Pressure Vessel at Midplane, Measured Values (LASL Group H-8)	1.6×10^6 r/hr-MW	5.1×10^5 r/hr-MW	1.9×10^6 r/hr-MW
Approximate Dose Rate in Contact with Pressure Vessel, Full Power	2.4×10^6 r/hr	2.6×10^6 r/hr	9.5×10^5 r/hr
Characteristic Gamma Source Power	129 MW	430 MW	43 MW
Dose Rate at 50' per Watt of Gamma Source Power-Core Sources only	15 mr/hr-watt	3 mr/hr-watt	36 mr/hr-watt
Approximate Dose Rate at 50', Full Power, Core Sources only	1.9×10^6 r/hr	1.3×10^6 r/hr	1.5×10^6 r/hr

Conclusions

With the possible exception of Phoebus 2, the agreement between rather simple radiation calculations and measurements near operating propulsion prototype reactors has been quite good. Considering that uncooled metals near high power systems exhibit the

ultimate in radiation damage - melting - the demonstrated ability to predict the environment during operation is very satisfying. An interesting outstanding problem is the rather persistent overprediction of dose rates post shutdown by a factor of $1\frac{1}{2}$ -2.

References

1. Worman, F.C.V., et al., LA-2858, "Integral Neutron and Gamma Dose Measurements on the Kiwi B-1 Reactors," March 1963.
2. Henderson, R.W., et al., LA-2885, "Integral Gamma and Neutron Measurements on Kiwi B-4A," March 1963.
3. Peterson, D.M., "Leakage Radiation Fields from the Kiwi B-1A," TID-7653, Proceedings of Nuclear Propulsion Conference, Naval Postgraduate School, Monterey, California, Aug. 1962.
4. Malenfant, R.E. and Graves, G.A., "Ground Test Radiation Experience at the Kiwi-B-4 Tests," AIAA Paper 65-593 (1965).
5. Worman, F.C.V., et al., LA-3286, "Integral Gamma and Neutron Measurements on the Kiwi B4D-202 and Kiwi B4E-301 Reactors," March 1965.
6. Ahlquist, A.J., et al., LA-3622-MS, "Test Cell C Shielding Study, Kiwi B4D-202," Nov. 1966.
7. Sanders, F.W., et al., LA-3447-MS, "Dose Rate Measurements on the Kiwi B4D-202 and Kiwi B4E-301 Reactors," Jan. 1966.
8. Graves, G.A., "Design and Performance of a Open-Well Shield for High Power Propulsion Reactor Testing," Vol. 3, p. 859, AERE-R5773, Proceedings of the Conference on the Physics Problems of Reactor Shielding, United Kingdom Atomic Energy Authority Research Group, Harwell, England 1968. Available through British Information Services, 845 3rd Avenue, New York, N.Y. 10022.
9. Malenfant, R.E., LASL Internal Memorandum N-2-8048 Corrected (1966).
10. Watson, C.W., private communication.
11. Malenfant, R.E., LASL Report LA-3573, "QAD, a Series of Point-Kernel General-Purpose Shielding Programs," (1967).
12. Ahlquist, A.J., et al., LA-3746, "Integral Gamma and Neutron Measurements on the Phoebus 1-B Reactor," Oct. 1967.
13. Ahlquist, A.J., LA-3747, "Gamma Dose-Rate Measurements on the Phoebus 1-B Reactor," July 1968.
14. Peterson, D.M., Graves, G.A., and Seale, R.L., "Studies of U^{235} Post-Fission Gamma and Beta Radiation and of Post-Shutdown Radiation Release from Fission Operation at Constant Power," to be published as Los Alamos Scientific Laboratory Report LA-2902.