

THERMIONIC REACTOR POWER SYSTEM:
EFFECTS OF RADIATION ON INTEGRATION WITH
MANNED SPACE STATION*

A. J. Gietzen, C. A. Heath, and L. W. Perry
Gulf General Atomic Company

The application of a thermionic reactor power system to the modular space station is described. The nominal net power is 40 kWe, with the power system designed to be applicable over the power range from 25 to 60 kWe. The power system is designed to be launched by the space shuttle. The lifetime goal is 5 years.

The reactor contains thermionic fuel elements, in which electrical power is produced, and U-ZrH driver fuel elements. The thermionic converter design is the same as that presently being tested in the Gulf General Atomic thermionic test reactor. There are enough fuel elements in the reactor to provide a high degree of redundancy at the nominal 40 kWe design point. Reject heat from the fuel elements is removed by forced convection NaK loops to the primary radiator where it is radiated to space at about 810°K (1000°F). Electrical power output from the reactor at about 9 V is carried to a modular power conditioning system where it is processed to higher voltage for transmission to the spacecraft.

Radiation protection is provided by LiH neutron shielding and W gamma shielding in a shaped 4π configuration, i.e., the reactor is shielded on all sides but not to equal extent. Isodose contours are presented for the region around the modular space station. Levels and spectral distribution of radiation are given for later evaluation of effects on space station experiments. Parametric data on the effects of separation distance on power system mass are presented.

An alternate concept in which a reactor system is connected to the Space Station by a tether at a distance of 1 to 2.5 miles is discussed. The effect upon power system performance and shielding requirements of the tethered concept are presented.

INTRODUCTION

A recent study on design and integration of reactor power systems for extended capability Space Stations (Ref. 1) recommended a power system capability of 40 to 50 kWe. The study identified the key criteria for the power system as growth capability and the ability to adjust to varying Space Station requirements.

The thermionic reactor power system for the Space Station is designed to a nominal power of 40 kWe with a beginning-of-life capability of 55 kWe. The power output is controllable over the entire power range from zero to 55 kWe. The same fuel element design used in this system is applicable over a wide power range and has been applied in specific design studies for 25 kWe and 100 kWe systems (Refs. 2,3). The thermionic fuel element (TFE) design has evolved from over 80,000 hr of laboratory testing and 64,000 hr of testing in the TRIGA thermionic test reactor of single and two-cell fuel elements. Two complete six-cell prototype fuel elements have been fabricated and are ready for testing in the reactor.

In the in-core thermionic reactor, the electrical power is produced by direct conversion of heat to electricity within the fuel element. The TFE serves the dual role of containing the fuel in the reactor as well as performing the power conversion. In the Gulf General Atomic concept, the power from each pair of TFEs is coupled to an independent power conditioning module to become a single power

production unit. The 40 kWe Space Station system contains 30 of these power production units, with 23 required for 40 kWe, to provide a modular power system with active redundancy.

The Space Station power system is described in detail in Ref. 4. This paper presents the guidelines and constraints applied to the power system design, and a general description of the overall system and of each subsystem. The shield is considered in more detail with a description of the configuration and data on dose rates, radiation spectral distribution and tradeoffs on weight and separation distance.

GUIDELINES AND CONSTRAINTS

The requirements imposed on the power system design by integration conditions include:

- Radiation dose rate at the station of 25 rem or less in a 6-month period
- Consideration of both rigid boom mounting at separation distances of 100 to 200 ft and tether mounting at 1 to 2.5 mi.
- Power system will be made up of 1 or more modules, each weighing no more than 20,000 lb.

*This work was sponsored by the U. S. Atomic Energy Commission under Contract AT(04-3)-167, Project Agreement 14.

- The power system will be confined within a 12 ft diameter by 50 ft long package.
- The nominal net power delivered to the spacecraft will be 40 kWe.

Additional design ground rules adopted for the reference power system design include:

- Design lifetime goal of 5 yr.
- Redundancy in power production units (TFE pair plus power conditioning module) of at least 25%.
- The basic fuel element design and materials the same as those presently built for testing in-pile
- Eutectic NaK coolant
- Stainless steel vessel and heat rejection system
- 1100°F reactor outlet temperature.

SYSTEM DESCRIPTION

The reference design power system (Fig. 1) consists of four major subassemblies: reactor, radiation shield, heat rejection system, and electrical power conditioning system. The reactor is made up of the reactor core containing the fuel elements and a neutron reflector which surrounds the core. Both the core and the reflector are contained within a stainless steel reactor vessel. The reactor sub-assembly includes the gaseous fission product storage traps and control drives.

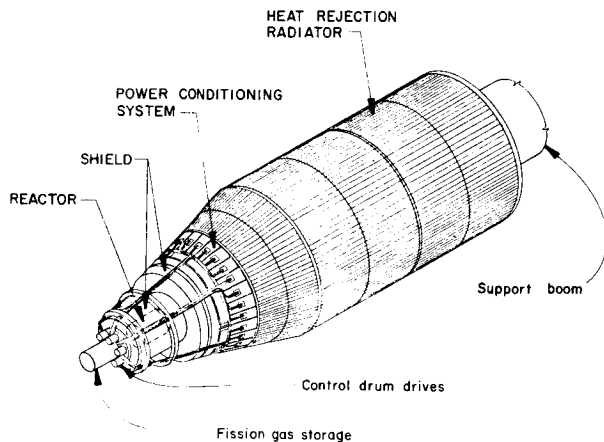

Fig. 1. Thermionic Reactor Space Station Power System

The thermal power produced in the reactor which is not converted to electricity is removed by the heat rejection system. This system consists of circulating liquid metal (NaK) loops, a heat exchanger, and a radiator. The NaK passing through the reactor becomes radioactive and would be a radiation hazard to personnel in the spacecraft if it flowed directly to the radiator. The heat is transferred to 5 radiator loops in a heat exchanger which is in a region around the reactor, shielded both from reactor and spacecraft. The radiator loops carry the heat to the radiator panels, each of which consists of 220 heat pipes making up an isothermal radiating surface.

The radiation shield protects space station personnel from nuclear radiation emanating from the reactor and from the activated reactor coolant. The reference shield is a shaped 4π shield giving a dose rate of 5 mrem/hr at 200 ft over a dose plane diameter of 130 ft. It consists of two portions; one surrounding the reactor which reduces the dose rate at the side and end of the reactor to 100 R/hr at 100 ft, and the other which provides the low dose shadow cone covering the Space Station.

The power conditioning system takes the electrical power from the reactor at approximately 10 V dc and converts it to higher regulated voltage, meeting space station requirements. Power is carried from the reactor to the power conditioning by insulated transmission lines cooled by direct radiation to space. The power conditioning system consists of 30 modules in each of which the mounting plate serves as a direct radiating heat sink for the electrical components.

The 40 kWe rating is net output capability of the system at end-of-life (EOL) after deduction of parasitic loss. The major system losses are the power dissipated in the transmission lines and power conditioning equipment, and the electrical power requirements of the electromagnetic pumps which circulate coolant.

The constraints on dose rate and dose plane diameter result in shield weights which preclude launch of the entire initial system on a single shuttle vehicle (with 20,000 lb. capacity). The system is designed to have a separable portion of the shield which can be launched with the support boom, reducing the power system module to about 12,000 lb. The station shield and boom become a permanent part of the space station. A replacement power system is easily accommodated on a single shuttle launch. The power system-station shield separation is illustrated in Fig. 2.

A summary of reference design power system parameters is given in Table 1. Descriptions of the major component assemblies are given in the following sections.

An alternate configuration for attachment to the station by a cable tether (1 to 2.5 miles) was also evaluated. This configuration (Fig. 3) offers potential advantages of reduced total system weight and minimum interaction with space station configuration and operations. Orbital mechanics and deployment techniques are being evaluated. A summary of the tethered system for a separation distance of 2 miles is given in Table 2.

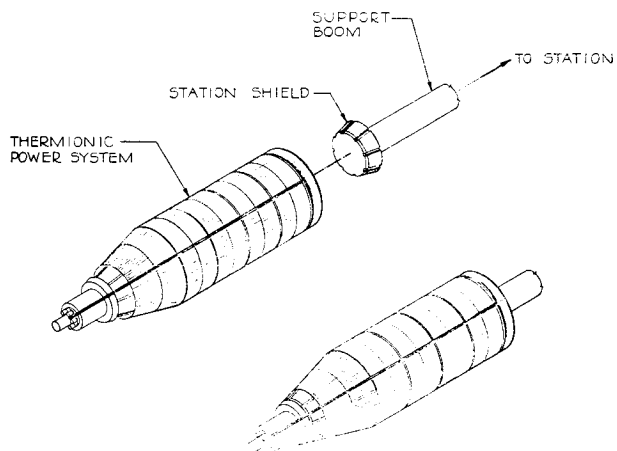

Fig. 2. Power System - Station Shield Separation

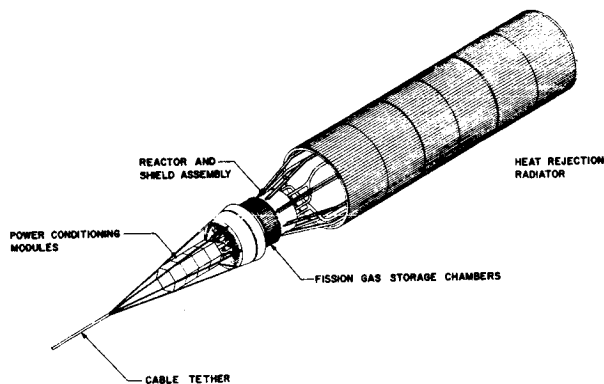

Fig. 3. Tethered Power System Configuration

TABLE 1
POWER SYSTEM SUMMARY

Net conditioned power	40 kWe
Beginning of life capability	55 kWe
Overall length	33 ft
Maximum diameter	12 ft
Power system weight (includes 4300 lb shield)	11,200 lb
Station shield and boom weight	18,900 lb
Total power subsystem weight	30,200 lb

TABLE 2
TETHERED POWER SYSTEM DESIGN SUMMARY

Net conditioned power	40 kWe
Beginning of life capability	65 kWe
Overall length	40 ft
Maximum diameter	8 ft
Power system weight	11,000 lb
Cable tether weight (approx.)	400 lb
Total power subsystem weight	11,400 lb

Reactor Design

The reactor subassembly is shown in Fig. 4. The reactor core contains thermionic fuel elements and uranium-zirconium hydride (U-ZrH) elements. The core contains 60 thermionic fuel elements (TFE) which produce the required electrical output. U-ZrH elements are added to achieve nuclear criticality. The core is surrounded by a radial reflector region containing 18 control drums which are composed of beryllium oxide reflector material with segments of neutron absorber. Nuclear control of the reactor is achieved by small rotational movements of the drums.

Each of the 60 thermionic fuel elements includes a vessel head feedthrough for passage of the electrical lead and radioactive gaseous fission products. Gaseous fission products produced within the TFEs are vented from the fuel element to prevent pressure buildup during long term operation. These gases (Xe and Kr) are vented to storage canisters filled with activated charcoal. The charcoal adsorbs the gases minimizing the containment volume required. Connection of a transmission line to each TFE is made in the region just below the gas storage chambers.

The control drives and control drum bearings use the technology developed for the U-ZrH reactor (Ref. 5). The drives are located outside the end shield where the radiation levels from the reactor are reduced and the drive motors are cooled by radiation to space.

A midplane cross section of the reactor is shown in Fig. 5. The core consists of two regions;

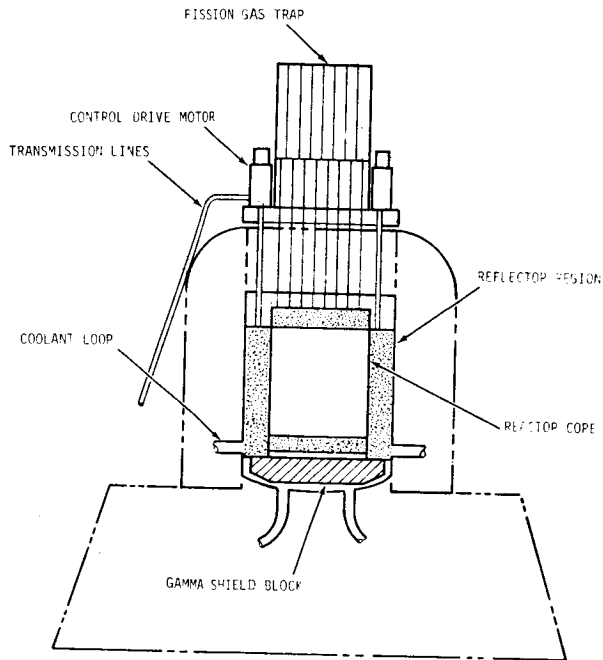

Fig. 4. Reactor Subassembly

The core and reflector regions are separated by a shroud which directs the incoming coolant through the reflector region before it flows back through the core. The control drums, which are contained in dry wells within the vessel, contain a segment of boron carbide neutron absorber which is rotated towards the core to shut down the reactor and away from the core to increase reactor power.

The fuel elements are supported at the top end by the vessel head and at the lower end by a grid plate (see Fig. 6). The grid plate is supported by the control drum dry wells.

A primary gamma shield is contained within the reactor vessel and is cooled by the circulating reactor coolant.

The NaK coolant enters the side of the vessel near the bottom, distributes in the small plenum area, and flows up through the reflector region to remove neutron and gamma heating energy. The coolant enters the core region through openings in the shroud, distributes in the region between the vessel head and upper end of the fuel elements, and flows down through the core. It passes through holes in the grid plate and through the shield block to the reactor outlet pipes. The coolant and vessel materials (NaK-78 and 316 SS) are the same as those in the reference U-ZrH reactor thermoelectric system.

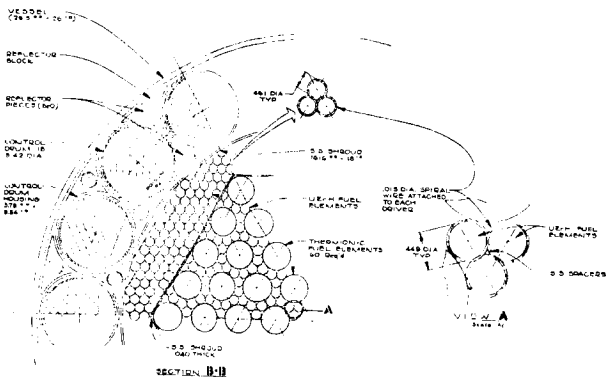

Fig. 5. Reactor Midplane Cross Section

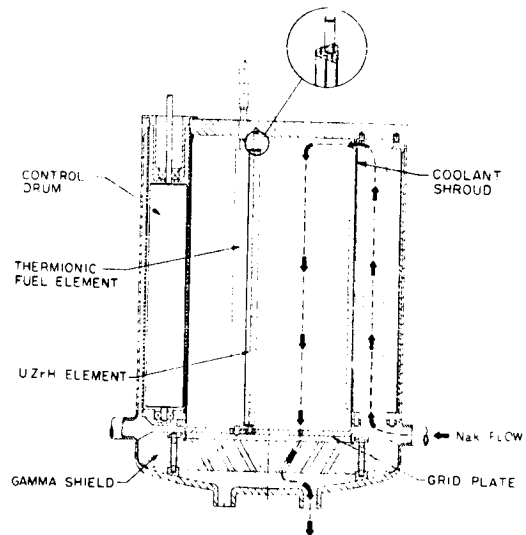

Fig. 6. Reactor Elevation Cross Section

the inner region contains both thermionic fuel elements and U-ZrH elements, and the outer region contains only U-ZrH elements. The U-ZrH elements apply the fuel technology developed for the U-ZrH reactor but are slightly smaller in diameter and operate at conditions which are less demanding than those for the U-ZrH thermoelectric system, i.e., clad temperatures 200°F lower and surface heat flux a factor of 2 lower.

The significant performance parameters and dimensions describing the reactor are given in Table 3. The number of TFEs required to produce the nominal output power, assuming operating conditions comparable to those of present in-pile TFE tests, is 46. The additional 14 TFEs allow operating at derated beginning of life (BOL) conditions to prolong life, and provide redundant power capability to compensate for potential TFE failures. The operating mode is such that if TFE performance degrades or failures occur, the power can be increased to maintain constant system power output. End of life (EOL) for the reactor is defined as the point at which an equivalent of 14 fuel elements have failed and the remaining 46 are operating normally.

TABLE 3
REACTOR PERFORMANCE PARAMETERS

Reactor outside diameter	26.5 in.	
Reactor length	25.0 in.	
Reactor mass	2176 lb.	
Number of thermionic fuel elements	60	
Number of U-ZrH fuel elements	813	
Number of control drums	18	
Control drum diameter	3.24 in.	
	<u>BOL</u>	<u>EOL</u>
Gross electrical output (kWe)	53	58
TFE surface heat flux, W/cm ²	25	31
Thermal power output, kW	1230	1510
Coolant inlet temperature, °F	890	960
Coolant outlet temperature, °F	1030	1100

Fuel Element Design

Two types of fuel elements are used; thermionic fuel elements in which the electrical power is produced, and U-ZrH fuel elements. The number of TFEs required for the 40 kWe output is less than required to achieve nuclear criticality on TFEs alone. The U-ZrH elements provide the additional uranium to achieve the required neutron multiplication as well as providing hydrogen for neutron moderation which enhances reactor safety.

The TFE is illustrated in Fig. 7. The TFE design has evolved through a development program which has included laboratory and in-reactor testing of experimental and prototype single cell and two-cell converters. Experimental electrically-heated converters have accumulated over 80,000 test hours with the longest single test continuing after 33,000 hours. Over 64,000 test hours have been accumulated on in-reactor converters with longest single tests of 10,000 hours on experimental converters, 7,700 hours on prototype single cells, and 6,600 hours (continuing) on a 2-cell TFE. Two 6-cell TFEs, which are essentially the same as the reference design (Fig. 7), but without the neutron reflector pieces, have been fabricated and are ready for testing in the TRIGA thermionic test reactor.

Each TFE contains 6 identical thermionic converters which convert about 11% of nuclear heat generated in them into electricity. Each fuel element produces about 1 kWe at 4 volts. Two TFEs are connected in series to a power conditioning module providing 30 independent power production units. The TFE is 1.314 in. in diameter and 25.3 in. long, including reflector pieces.

The U-ZrH element uses the same materials as the fuel elements developed for the U-ZrH reactor program but operates at lower temperatures and heat fluxes. The reactor outlet temperature is 1030°F at BOL and 1100°F at EOL. The diameter of the U-ZrH element is 0.45 in. in the TFE zone where the surface heat flux is 2.5 W/cm² at EOL. The diameter is 0.46 in. in the driver zone where the peak heat flux is 10 W/cm² at EOL.

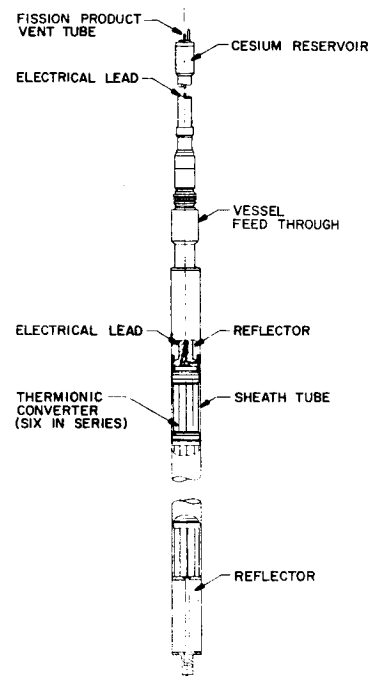

Fig. 7. Thermionic Fuel Element

Heat Rejection System Design

The heat rejection system (shown schematically in Fig. 8) consists of reactor and radiator NaK loops, a heat exchanger, and heat pipe radiator panels. The reactor loop is divided into two circuits (each having its own electromagnetic induction pump) to reduce the size of shield penetrations and provide improved flow distribution in the reactor. Reactor loop temperature at the reactor outlet is 1030°F at BOL and 1100°F at EOL. Heat is transferred from the primary reactor loop to five radiator loops in a counterflow tube-in-shell heat exchanger located around the reactor shield. Each of the radiator loops is independent and carries the heat to one of five radiator panels which are arranged in a cylindrical configuration. The heat is distributed over the surface of each panel by heat pipes using potassium as the working fluid.

The heat pipe panels are placed on the outside of the radiator loops and provide meteoroid protection for the liquid metal loops. Failure of one of the five secondary loops results in an average heat rejection system temperature increase of about 80°F at the reference operating power level. A summary of heat rejection system parameters is given in Table 4.

Power Conditioning and Transmission Lines

The power conditioning (P.C.) system consists of 30 individual modules, one for each pair of thermionic fuel elements. Each module consists of an inverter to convert low-voltage dc to square-wave ac, a transformer to increase the voltage, and a rectifier to convert the high voltage ac to dc. Analysis of the basic P.C. module circuit is given in Ref. 6. The output from some or all of the modules is fed to a common bus for transmission to the spacecraft.

Shield Configurations

Shield designs have been prepared for the two basic concepts considered, the reactor placed on a boom attached to the space station or at the end of a long tether at a distance of 1 to 2.5 miles. The basic dose constraint of no more than 25 rem to be received at the space station during a 6-month period applies to either concept. This total dose corresponds to an hourly rate of 5.7 mrem/hr.

As shown in Table 3, the thermal power of the nuclear reactor may increase throughout the mission to compensate for any failures of the independent power modules. In order to provide adequate shielding without regard to the actual time of failure of the redundant elements, radiation protection is designed for the highest reactor power level corresponding to end-of-life conditions. In this particular case, therefore, the allowable dose rate at the space station was taken to be 5 mrem/hr at a reactor power level of 1740 kW.

Beyond the nominal requirement for the allowable dose at the space station, consideration has to be given to the radiation field in all directions around the reactor because of requirements for rendezvous and docking maneuvers, possible placement of experimental modules outside the actual space station, and other possible activities in the vicinity of the space station. The radiation dose environment around a U-ZrH thermoelectric reactor placed on a space station is shown in Fig. 9 (Ref. 1). The shield for the thermionic reactor system has been sized to provide a radiation environment equal to or less than that shown in Fig. 9.

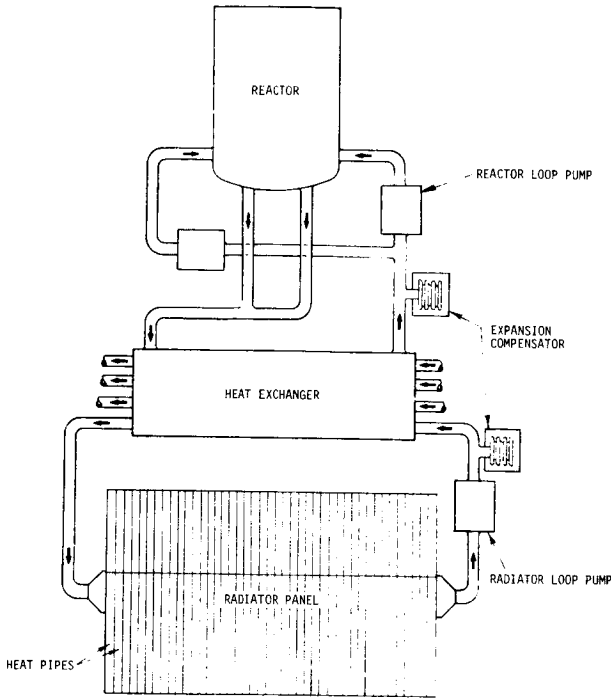

Fig. 8. Heat Rejection System Schematic

TABLE 4
HEAT REJECTION SYSTEM PARAMETERS

Radiator area	810 ft ²	
Radiator diameter	12 ft	
Heat pipe material	K in 316 SS	
Radiator weight	1990 lb	
Total heat rejection system weight	3600 lb	
	<u>BOL</u>	<u>EOL</u>
Average reactor loop temperature, °F	960	1030
Average radiator loop temperature, °F	920	990
Average radiator temperature, °F	900	975

A "direct radiating" concept is used in which heat dissipated in the P.C. components is radiated directly from the mounting plate of each module.

Transmission of the power from the reactor to the power conditioning is through four bundles of aluminum busbars which run along the outer surface of the shield and power conditioning structure and radiate the ohmic losses directly to space. All busbars in a bundle are insulated from one another to remain independent in the event of fuel element failures.

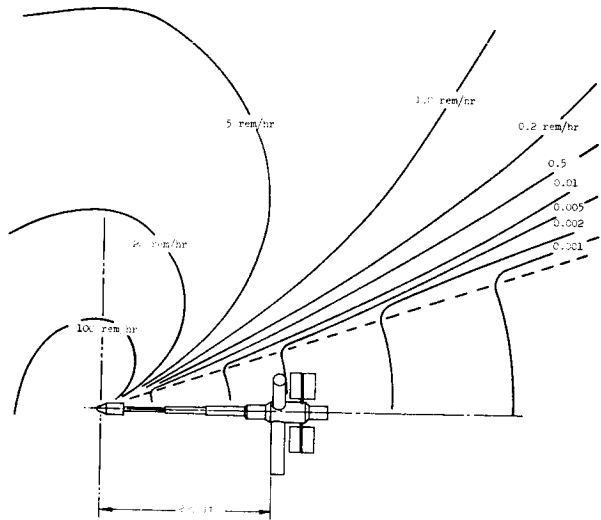

Fig. 9. Radiation Environment from Nuclear Reactor

The shield configuration for the thermionic reactor system mounted on a rigid boom is illustrated in Fig. 10. A relatively thin shield is provided at the side and top of the reactor to meet the requirement of no greater than 100 R/hr at a distance of 100 feet. A multilayer station shield is provided to shield a dose plane of 130 ft diameter at a separation distance of 200 feet. The resulting half-angle for the shield cone is 17.3°.

The intermediate heat exchanger and other liquid metal loop components have been placed adjacent to the reactor rather than in an intermediate gallery region. Elimination of the gallery permits a weight saving by reducing the diameter of the second layer of gamma shielding since it is placed closer to the apex of the shielding cone. The amount of activation of the secondary NaK passing through the heat exchanger was included in evaluating the dose rates at the space station. The secondary NaK is distributed over the area of the radiator which becomes a gamma source outside the reactor shield. This problem is considered further below.

TABLE 5
SHIELD DIMENSIONS

Boom Mounted Reactor		
Crew Shield	Tungsten	5.08 cm
	LiH	21.60 cm
	Tungsten	8.38 cm
	LiH	51.30 cm
Side Shield	Tungsten	0.63 cm
	LiH	31.00 cm
Tethered Reactor		
4 π Shield	LiH	33.00 cm
Power Conditioning Shield	LiH	88.20 cm
	Tungsten	7.60 cm

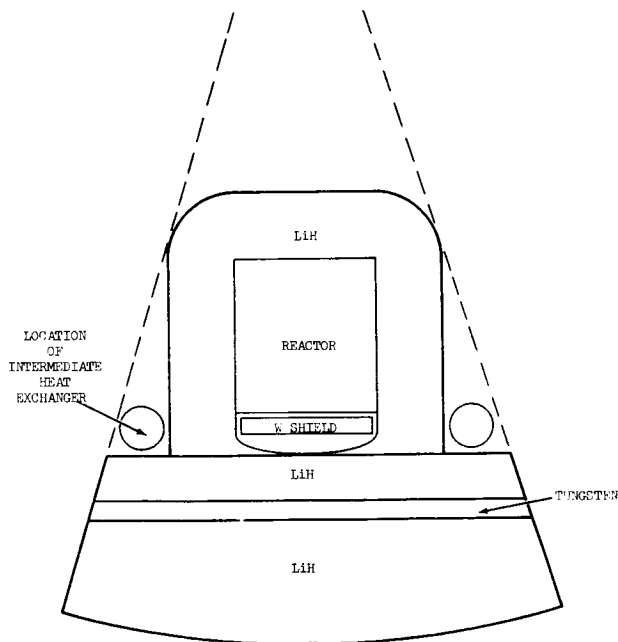

Fig. 10. Shield Configuration for Boom Mounted Reactor

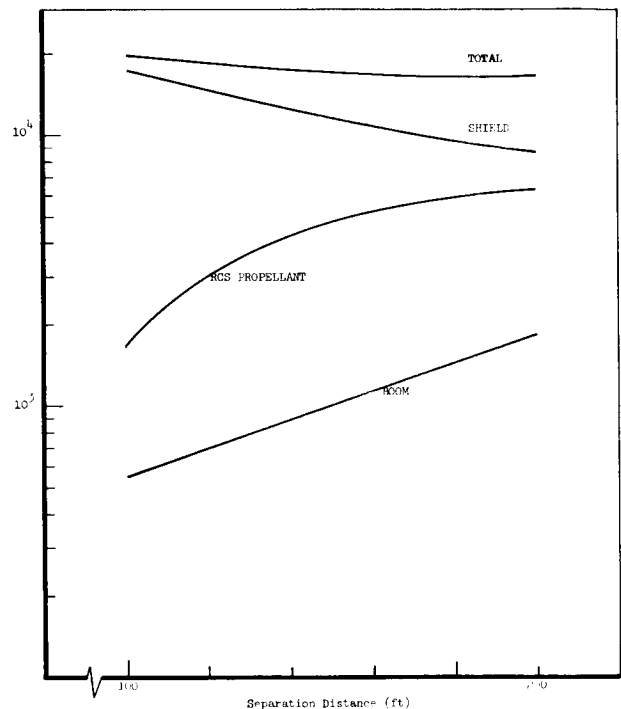

Fig. 11. Mass of Reactor Shield and Boom for Varying Separation Distance

The dimensions of the thermionic reactor shield are summarized in Table 5 for a separation distance of 200 feet and a dose plane diameter of 130 feet. Total shield mass for this configuration is 19,200 lb. (8700 kg). The effect of varying the length of the boom between the reactor and the space station is illustrated in Fig. 11. The masses of the boom and the propellant required by a reaction-control system for varying separation distances were supplied by NASA MSFC personnel (Ref. 7). The resulting total mass of shield, boom, and propellant has a broad minimum between 150 and 200 ft. separation.

The shield configuration for the tethered reactor concept is illustrated in Fig. 12 with dimensions given in Table 5. A 4 π shield is provided to meet the space station dose limits at a separation of 2 miles. A thicker shaped shield at one end of the reactor protects the power conditioning equipment from direct reactor radiation and backscatter from heat rejection radiator and components. This shield is designed to reduce the dose to the power conditioning equipment to 10⁶ rads of gamma rays and 10¹² nvt of fast neutrons over a five-year operating lifetime. Total shield mass for the tethered system is 5733 lb. (2606 kg).

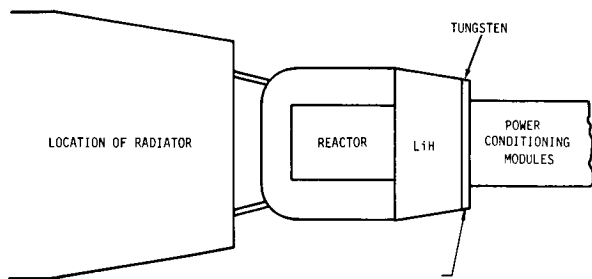

Fig. 12. Shield Configuration for Tethered Reactor System

The secondary coolant fluid, NaK-78, is also a source of radiation to the space station when it is distributed throughout the heat rejection radiator. It is important, therefore, that the side shielding shown in Fig. 10 be thick enough to reduce the neutron activation of secondary NaK in the heat exchanger to tolerable levels. For the system design shown in Fig. 1, the total volume of NaK-78 in the secondary loop is 0.042 m^3 (1.5 ft^3). The dose received at the dose plane from the activated coolant in the radiator is shown in Fig. 13 for separation distances of 150 and 200 feet. For the reference side shield thickness of 12.2 in., the dose received at a separation distance of 200 ft is 0.17 mr/hr. It is concluded that placement of the intermediate heat exchanger in the location shown in Fig. 10 is feasible from the standpoint of dose levels from activated secondary coolant.

Contributions to Radiation Dose

Nuclear radiation from the power system includes neutrons and gamma rays generated in the reactor core, secondary gammas generated by neutron interactions within the shield, and gamma rays from the coolant activated by neutron absorption in the intermediate heat exchanger. Table 6 presents the differential spectrum of neutrons and gamma rays for radiation received from primary and secondary sources in the reactor and shield, for the boom-mounted reactor system. The data is normalized to 1 mrem/hr of that particular radiation type. Although the highest values of the neutron spectrum appear in the lower energy groups, it should be noted that the major contribution to the dose comes from the fast neutrons. For example, the four highest groups, representing those neutrons with energy above 1 MeV, contribute 80% of the total dose from neutrons inside the shielded cone.

TABLE 6

SHIELDED NEUTRON AND GAMMA RAY SPECTRA

Group	Upper Energy (eV)	Neutrons (1) (n/cm ² -sec-eV)		Gammas (2) (photons/cm ² -sec-eV)	
		Inside Shield Cone	Outside Shield Cone	Upper Energy (eV)	Inside Shield Cone
1	$1.49 + 7^*$	$1.00 - 7$	$1.04 - 8$	9×10^5	$2.190 - 8$
2	$8.15 + 6$	$4.15 - 7$	$1.10 - 7$	7×10^5	$6.230 - 6$
3	$5.49 + 6$	$4.88 - 7$	$2.53 - 7$	5×10^5	$2.600 - 5$
4	$3.68 + 6$	$1.03 - 6$	$1.56 - 6$	3×10^5	$4.480 - 5$
5	$1.00 + 6$	$2.19 - 6$	$3.80 - 6$	2.5×10^5	$6.070 - 5$
6	$7.45 + 5$	$2.31 - 6$	$5.45 - 6$	2×10^5	$6.660 - 5$
7	$3.02 + 5$	$2.79 - 6$	$5.16 - 6$	1.5×10^5	$1.281 - 4$
8	$2.24 + 5$	$5.80 - 6$	$1.12 - 5$	1×10^5	$2.115 - 4$
9	$8.65 + 4$	$1.10 - 5$	$2.18 - 5$	$.5 \times 10^5$	$8.980 - 4$
10	$2.48 + 4$	$3.42 - 5$	$6.94 - 5$		
11	$5.53 + 3$	$1.04 - 4$	$2.16 - 4$		
12	$2.61 + 3$	$2.14 - 4$	$4.49 - 4$		
13	$1.23 + 3$	$4.38 - 4$	$9.31 - 4$		
14	$5.83 + 2$	$1.60 - 3$	$3.49 - 3$		
15	$4.79 + 1$	$1.39 - 2$	$3.12 - 2$		
16	2.38	$3.91 - 2$	$8.77 - 2$		

* $1.49 + 7$ equals 1.49×10^7

(1) normalized to 1 mr/hr of neutron dose

(2) normalized to 1 mr/hr of gamma dose

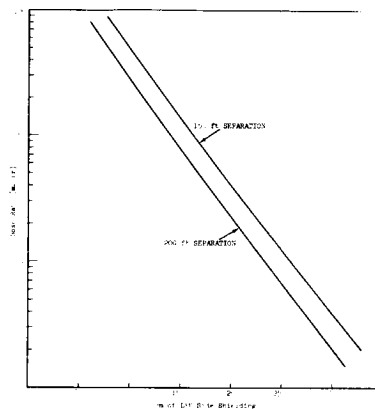

Fig. 13. Dose Received at Dose Plane from Activated Boundary Coolant

References

1. "Reactor Power System Design Document, MDC G0750, McDonnell Douglas Astronautics Company, December 1970, Vol. 1.
2. Gietzen, A. J., C. R. Fisher, and W. G. Homeyer, "25 kWe Thermionic Power System for Space Station Application," presented at IEEE 1970 Thermionic Conversion Specialist Conference, October 29, 1970, Miami Beach.
3. Gietzen, A. J., and W. G. Homeyer, "100 kWe Thermionic Power System Design," presented at IEEE 1970 Thermionic Conversion Specialist Conference, October 29, 1970, Miami Beach.
4. Gietzen, A. J., et al, Gulf General Atomic Company, "Nuclear Thermionic Space Station System Design," Report GA-10535, to be published.
5. Gylfe, J. D., and R. A. Johnson, "Reactor - Thermoelectric System for NASA Space Station," USAEC Report AI-AEC-12839, Atomics International, July 1969.
6. Gietzen, A. J., "Low Voltage Power Conditioning for a Thermionic Reactor," Gulf General Atomic Incorporated Report GAMD-9603, July 1969.
7. Brantley, L. W., NASA/Marshall Space Flight Center, private communication.