

# NASA TECH BRIEF

## Manned Spacecraft Center



NASA Tech Briefs announce new technology derived from the U.S. space program. They are issued to encourage commercial application. Tech Briefs are available on a subscription basis from the National Technical Information Service, Springfield, Virginia 22151. Requests for individual copies or questions relating to the Tech Brief program may be directed to the Technology Utilization Office, NASA, Code KT, Washington, D.C. 20546.

### Improved Measurement of Depth Perception

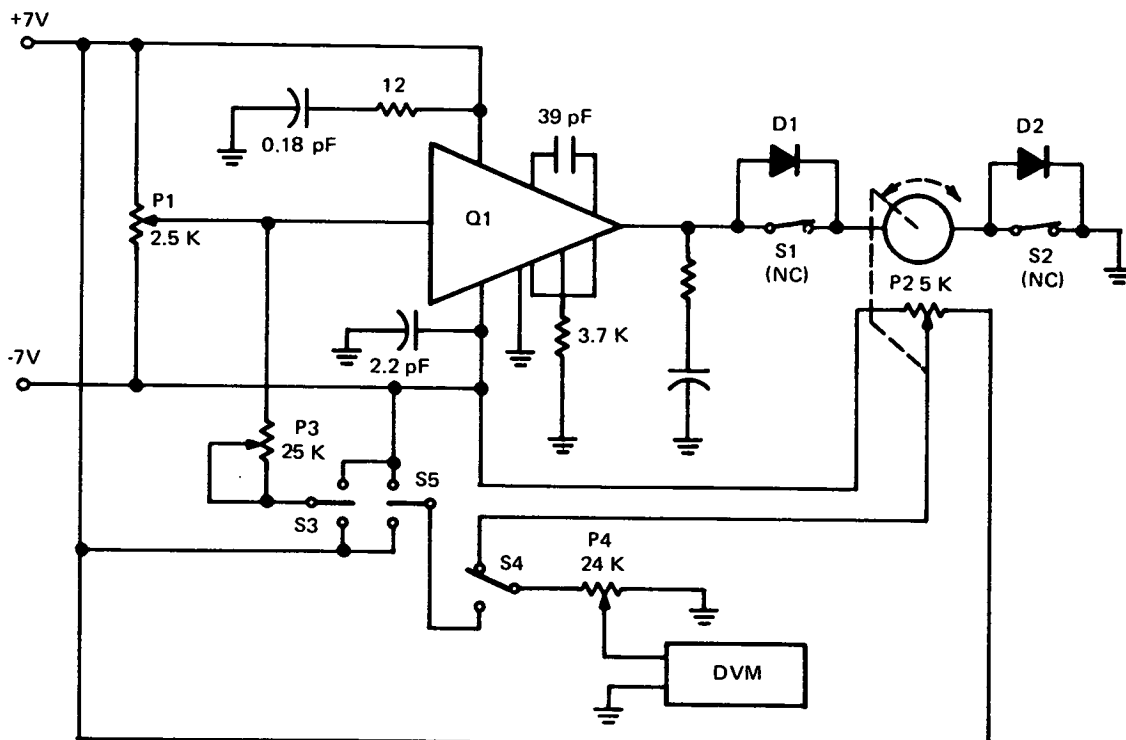

Note: All Resistances Are In Ohms

Circuit Diagram Of Motorized Howard-Dolman Device

#### The problem:

The Howard-Dolman apparatus is used to measure depth perception by having the subject attempt to align a movable peg with a reference object. Usually, the subject aligns the peg by pulling on a pair of strings which are attached to the front and back of the peg. Since the subject can feel how far he has moved the peg, it is thought that stimuli other than vision are interfering with the depth perception measurement.

#### The solution:

The peg is moved by a newly developed electro-mechanical device which eliminates the tactual stimulus associated with pulling the strings.

#### How it's done:

This motorized version of the Howard-Dolman device consists of three modules: (1) the light box, which contains the stage for the moving peg, the lights, the

(continued overleaf)

motor drive amplifier, and the power supply; (2) the experimenter's box, which contains central switches and a digital voltmeter; and (3) the subject's box, which contains a joystick-operated potentiometer. With this system, the subject must position the peg without tactual feedback. In addition, the readout circuitry provides a more accurate measurement of the subject's performance than the manual method provides.

The electronic circuit for the device is shown in the diagram. Potentiometer P1 (mounted in the subject's control box) is normally held in its centered position by the joystick centering springs. When the joystick is moved, a voltage is developed at the input to the amplifier Q1. Between the output of the amplifier and the ground, there is a small, permanent-magnet motor. The motor and its associated clip-on reducing gear are mounted on a movable platform and drive the platform along a precision rack by means of a gear mounted on potentiometer P2. If the platform is driven to its rear limit, switch S1 is opened, and further motion in that direction is stopped. Diode D1 allows current flow in the opposite direction to permit the appropriate input

signal to back the platform away from the stop. Switch S2 and diode D2 perform the same function at the opposite limit of platform travel.

**Note:**

Requests for further information may be directed to:  
Technology Utilization Officer  
Manned Spacecraft Center  
Code JM7  
Houston, Texas 77058  
Reference: TSP72-10730

**Patent status:**

NASA has decided not to apply for a patent.

Source: R. C. Fitch  
Manned Spacecraft Center, and  
D. D. Miller of  
Technology Inc.  
under contract to  
Manned Spacecraft Center  
(MSC-14133)