

NASA TECH BRIEF

Ames Research Center



NASA Tech Briefs announce new technology derived from the U.S. space program. They are issued to encourage commercial application. Tech Briefs are available on a subscription basis from the National Technical Information Service, Springfield, Virginia 22151. Requests for individual copies or questions relating to the Tech Brief program may be directed to the Technology Utilization Office, NASA, Code KT, Washington, D.C. 20546.

Reverse-Osmosis Membranes by Plasma Polymerization

Thin polymer films of allyl amine can be formed on microporous filters by polymerization in a radio-frequency electrodeless plasma; the films have been found to provide dry composite membranes which are very effective in reverse-osmosis processes. For example, a thin film formed on a porous filter substrate by plasma polymerization in a high-frequency discharge (13.56 MHz) at about 13 N/m^2 (0.1 torr) exhibits as much as 98 percent sodium chloride rejection; furthermore, the film also exhibits a 46-percent urea rejection from a feed solution containing sodium chloride and urea (each at 10 g/l).

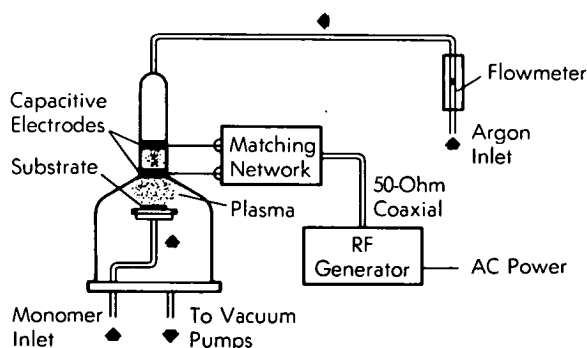

The procedure for forming the membranes first requires that degassed allyl amine be admitted via a needle valve to a bell jar which has been evacuated to a background pressure of less than 0.13 N/m^2 (10^{-3} torr); see diagram. System pressure (controlled by flow of allyl amine) is stabilized at about 13 N/m^2 , and then a stream of argon or inert gas is allowed to enter the bell jar. When the total pressure (amine flow and argon flow) is at about 27 N/m^2 , RF energy

is applied until a discharge is initiated. The system is operated until a desired thickness of film has been deposited on the substrate (usually a membrane $0.1-$ or $0.025\text{-}\mu\text{m}$ thick with its shiny side up). The distance from the substrate to the lower (ground) electrode is about 4 cm.

The plasma polymerization of allyl amine proceeds smoothly, and a light tan polymer deposit forms readily. Film thicknesses ranging from 0.8 to $1.6 \mu\text{m}$ can be obtained within 8 to 40 minutes. Films produced in 38 minutes at 40 watts of net RF power demonstrated the rejection values given above; films produced after $1\frac{1}{2}$ hours of polymerization were found to be impermeable. Water fluxes of $135 \text{ l/m}^2/\text{day}$ were achieved ($3.3 \text{ gal/ft}^2/\text{day}$).

Advantages of the plasma polymerization technique for producing reverse-osmosis membranes include: control of film thickness by control of plasma parameters, a wide variety of substrates and substrate configurations can be coated, deposition times are short, and there is high adhesion of films to the substrate. Membranes produced by plasma polymerization have few imperfections (i.e., pinhole-free) and they need be only $1.0\text{-}\mu\text{m}$ thick or less for high salt rejection; moreover, the films are dry (no storage problems) and a minimal amount of compaction is anticipated during reverse osmosis.

Plasma polymerization appears to provide a new approach to the synthesis of reverse-osmosis membranes, and it is conceivable that a large variety of organic monomers can be polymerized by the described technique.

(continued overleaf)

Note:

Requests for further information may be directed to:

Technology Utilization Officer
Ames Research Center
Moffett Field, California 94035
Reference: TSP72-10710

Patent status:

Inquiries concerning rights for the commercial use

of this invention should be addressed to:

NASA Patent Counsel
Mail Code 200-11A
Ames Research Center
Moffett Field, California 94035

Source: John R. Hollahan and Theodore Wydeven
Ames Research Center
(ARC-10696)