

October 1972

# NASA TECH BRIEF

## Marshall Space Flight Center



NASA Tech Briefs announce new technology derived from the U.S. space program. They are issued to encourage commercial application. Tech Briefs are available on a subscription basis from the National Technical Information Service, Springfield, Virginia 22151. Requests for individual copies or questions relating to the Tech Brief program may be directed to the Technology Utilization Office, NASA, Code KT, Washington, D.C. 20546.

### Fluid Operated Quick Release Mechanism

#### The problem:

In general, explosive bolt and squib-operated release mechanisms are not reusable and do not have the necessary reliability for use in hazardous environments.

#### The solution:

A gas operated release mechanism releases a load by fluid pressure to provide a positive action quick-release. Such a method can be used with large loads and is useful in repetitive cycling functions where shear pins and similar devices would be cumbersome.

#### How it's done:

In one application, this device is used to restrain the shaft of a linear motor. The primary restraining devices are three balls which are held in position in a notch in the

shaft. The principle of operation of such a ball locking device is to provide a means for the ball to be released from contact with the shaft and permit shaft motion.

The illustration shows the locking device. The balls are released when a piston in the release mechanism is moved until a release detent in the ball release ring is above each ball. In this gas activated system, the piston is held in position by a spring. To release the balls, low pressure nitrogen is introduced into the piston chamber, and the piston is forced back allowing the ball to move into the release notch.

When the piston reaches the stop position, the balls are lifted clear of the shaft and confined on a tapered shelf. Here they will not rebound against the shaft during the short interval of high-speed oscillation experienced by the shaft for several cycles after the initial driving thrust.

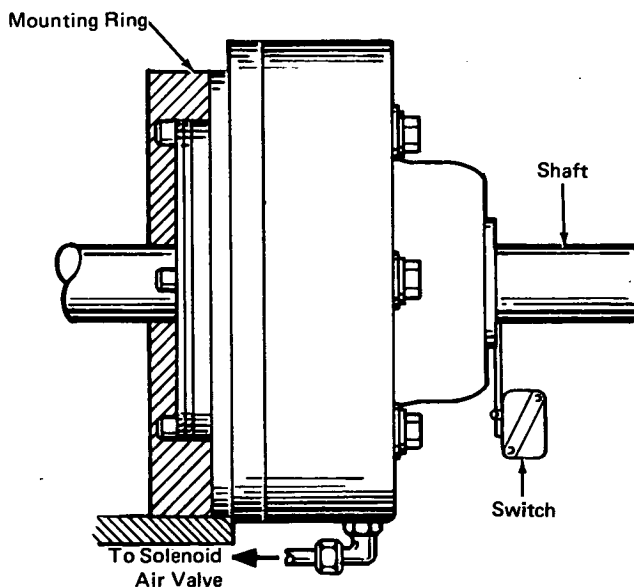
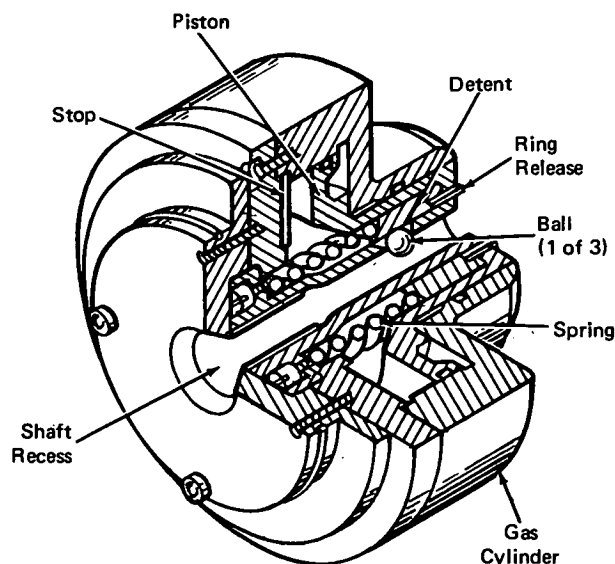

Side View

(continued overleaf)

The dry nitrogen, used to move the piston, is stored in a cylinder and introduced to the piston chamber by a solenoid air valve. The piston is returned to the lock position by venting the air from the piston chamber.

This system may be adapted for other uses such as with explosive bolts or a short stroke actuator. When use with heavy loads is desired, locking rollers may be used in place of the locking balls.

**Notes:**

1. This mechanism was tested successfully for several months with shaft loadings up to 3540 Kg (7790 lbs) and at gas pressures up to  $2.62 \times 10^6$  N/m<sup>2</sup> (360 psi).

2. No further documentation is available. Specific questions, however, may be directed to:  
Technology Utilization Officer  
Marshall Space Flight Center  
Code A&PS-TU  
Marshall Space Flight Center, Alabama 35812  
Reference: B72-10640

**Patent status:**

NASA has decided not to apply for a patent.

Source: R. A. Brown of  
Sperry Rand Corp.  
under contract to  
Marshall Space Flight Center  
(MFS-20205)