

NASA TECH BRIEF

Langley Research Center



NASA Tech Briefs announce new technology derived from the U.S. space program. They are issued to encourage commercial application. Tech Briefs are available on a subscription basis from the National Technical Information Service, Springfield, Virginia 22151. Requests for individual copies or questions relating to the Tech Brief program may be directed to the Technology Utilization Office, NASA, Code KT, Washington, D.C. 20546.

A Transmitting and Reflecting Diffuser for Ultraviolet Light

The problem:

A good diffuser for ultraviolet light, comparable to opal glass for visible light, does not exist. Absorption in the diffusing layer or scattering out the edge of the diffuser causes the diffusion pattern to deviate from the perfect cosine law. When a thin diffusing layer is used to avoid absorption, a large undesirable specular (non-scattered) component of the ultraviolet light remains.

The solution:

Fabrication of an ultraviolet diffusing layer in a configuration that uses the ultraviolet properties of a fused silica condensate.

How it's done:

A fused silica rod is vaporized in the flame of an oxy-acetylene torch and the vapor is condensed on a substrate of polished, ultraviolet grade, fused silica. Since the oxy-acetylene torch flame is the medium of transport for the fused silica vapor, the substrate must be placed very near the flame for proper deposition of the condensate. Because this condensed layer is somewhat fragile, the oxy-acetylene torch flame is played over (by mechanically moving the substrate or torch) the flat white vapor moving to vitrify the surface of the layer, making the coating more durable. The optimum coating thickness for a transmitting diffuser is approxi-

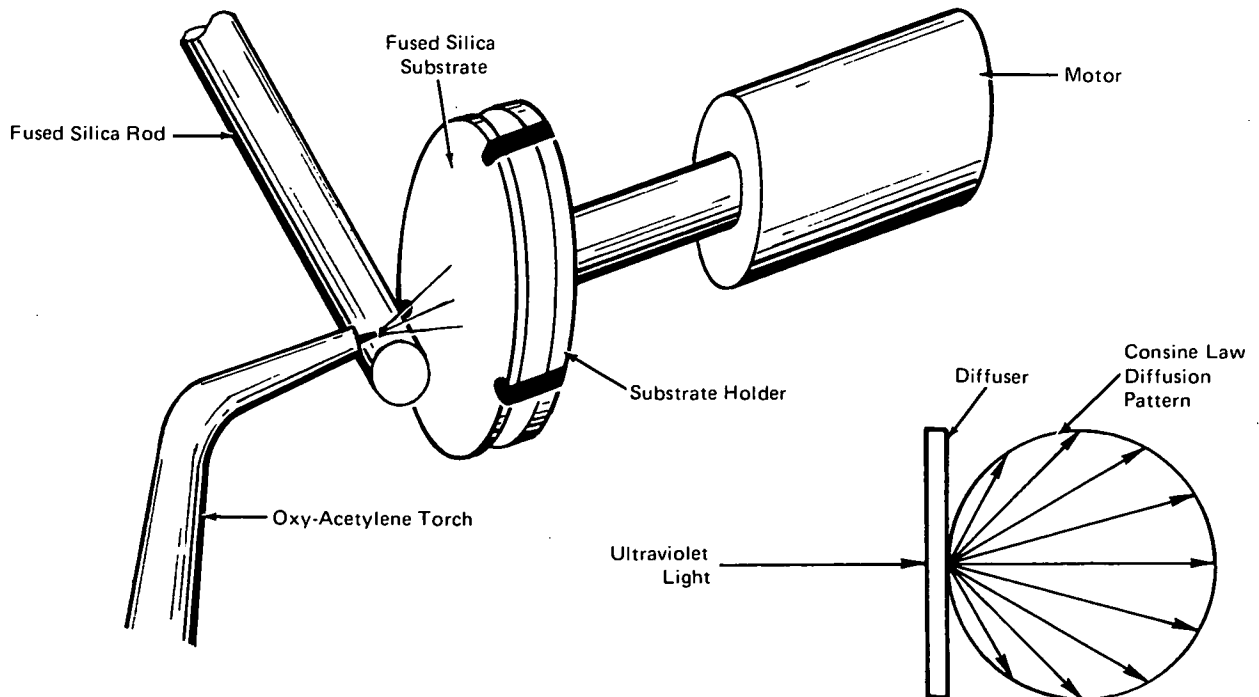

(continued overleaf)

mately 20 micrometers. Thinner coatings deviate from the cosine-law pattern and thicker coatings reduce the overall transmittance. If the diffuser is to be used as a reflector, the surface is not vitrified, and the coating thickness is increased to approximately 100 micrometers.

The diffuser can be made in practically any shape and size; and being a passive element it operates simply by insertion into the path of the ultraviolet light to be scattered. Its performance in the ultraviolet range from 2000 to 4000 angstroms is superior to that of opal glass in the visible light as a transmitting diffuser. As a reflecting diffuser, its performance is superior to $MgCO_3$ or MgO in the range from 2000 to 4000 angstroms and comparable to these standard reflectors in the visible light.

Notes:

1. This device can be used in an optical laboratory or optical equipment requiring the diffusion or scattering of ultraviolet light.

2. When used as a reflecting diffuser it is not necessary to use the fused silica substrate.
3. Requests for further information may be directed to:
Technology Utilization Officer
Langley Research Center
Langley Station/Mail Stop 139A
Hampton, Virginia 23365
Reference: TSP72-10611

Patent status:

Inquiries concerning rights for the commercial use of this invention should be addressed to:

Patent Counsel
Langley Research Center
Mail Code 456
Langley Station
Hampton, Virginia 23365

Source: Lloyd S. Keafer, Jr,
Ernest E. Burcher, and
Leonard P. Kopia
Langley Research Center
(LAR-10385)