

September 1972

B72-10574

# NASA TECH BRIEF

## Goddard Space Flight Center



NASA Tech Briefs announce new technology derived from the U.S. space program. They are issued to encourage commercial application. Tech Briefs are available on a subscription basis from the National Technical Information Service, Springfield, Virginia 22151. Requests for individual copies or questions relating to the Tech Brief program may be directed to the Technology Utilization Office, NASA, Code KT, Washington, D.C. 20546.

### Self-Deploying "Boom"

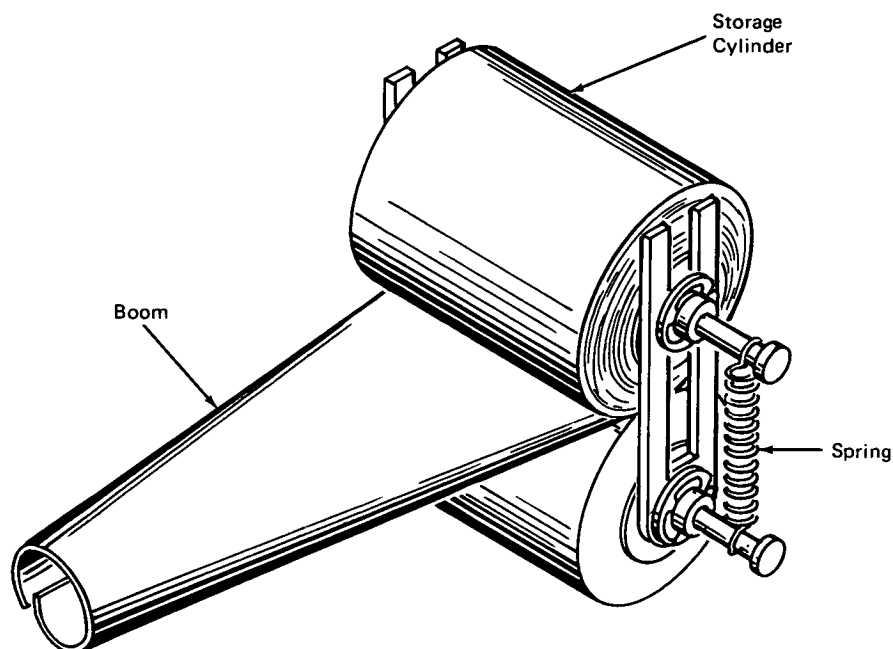

#### The problem:

A "boom" consisting of a metal ribbon wound on a spool tends to unwind during storage and, in typical self-deploying mechanisms, cannot be retracted after deployment.

#### The solution:

A self-deploying boom mechanism prevents premature unwinding, permits controlled or total deployment, and allows the boom to be retracted.

#### How it's done:

The device uses two interacting cylindrical rollers. One roller serves as a storage spool upon which the boom is wound, and the other acts as a boom restraint (see figure). The cylinders are joined by a spring which maintains a constant pressure against the wound boom, to

keep it tightly wound on the storage spool during deployment.

The boom, as stored on the cylinder, is flat, but it is prestressed to curl into a cylinder on deployment. Upon winding, the two cylinders flatten the curled boom so it may be stored in the flat configuration. Self-deployment is achieved by means of the stored energy of the wound boom element.

This mechanism can be used to deploy two or more booms at the same time. For two booms, this is done by winding a boom on each roller, and the device works in essentially the same way as before. To deploy several booms, a number of rollers are arranged in a circle in a manner similar to a "sun and planetary" gear system. In this configuration, each storage spool interacts with a common restraint roller.

(continued overleaf)

**Note:**

Requests for further information may be directed to:  
Technology Utilization Office  
Goddard Space Flight Center  
Code 207.1  
Greenbelt, Maryland 20771  
Reference: B72-10574

**Patent status:**

This invention has been patented by NASA (U.S. Patent No. 3,608,844). Inquiries concerning non-exclusive or exclusive license for its commercial development should be addressed to:

Patent Counsel  
Goddard Space Flight Center  
Code 204  
Greenbelt, Maryland 20771

Source: William T. Tumulty and Wayne P. Sours  
Goddard Space Flight Center  
(GSC-10566)