

NASA TECH BRIEF

Ames Research Center



NASA Tech Briefs announce new technology derived from the U.S. space program. They are issued to encourage commercial application. Tech Briefs are available on a subscription basis from the National Technical Information Service, Springfield, Virginia 22151. Requests for individual copies or questions relating to the Tech Brief program may be directed to the Technology Utilization Office, NASA, Code KT, Washington, D.C. 20546.

Photomultiplier Blanking Circuit

It is necessary to protect a photomultiplier from the destructive current surges which occur when it is exposed to brilliant illumination. For example, a photomultiplier is operated at very high voltages in order to sense the very low light levels in the precursor region in shock-tube measurements but, since the radiative intensity is many decades higher when the incident shock wave arrives in the field of view, the photomultiplier must be shielded from the damaging effects of the radiant pulse.

In the past, intense radiant pulses have been blocked by mechanical shutters, or the high voltage input to the photomultiplier has been momentarily short circuited. Unfortunately, very fast shutter closures (i.e., less than 1 millisecond) are not readily achieved and, as a result, complicated shuttering devices have had to be developed. For example, to obtain closures within 10 microseconds or less, powder charges or high-current magnetic pulses are needed to force a shutter to move into the field of view of the detector system. Electronic systems which short circuit high voltage power supplies in microseconds also require complex circuitry and devices, such as ignitrons; moreover, the power supply must be designed to withstand a short circuit at its output.

The photomultiplier blanking circuit shown in the diagram makes use of the fact that the overall gain of the photomultiplier is the product of the gain of each stage of multiplication in the dynode chain. Thus, if the gain of one stage is reduced to zero, the overall gain is also brought to zero. The circuit operates as follows: With the high voltage supply on and the silicon controlled-rectifier (SCR) not conducting, the photomultiplier is biased normally and has

the high gain required to measure low levels of radiant energy. When a blanking pulse is applied, the SCR is triggered into conduction and the voltage between the cathode and the second dynode drops

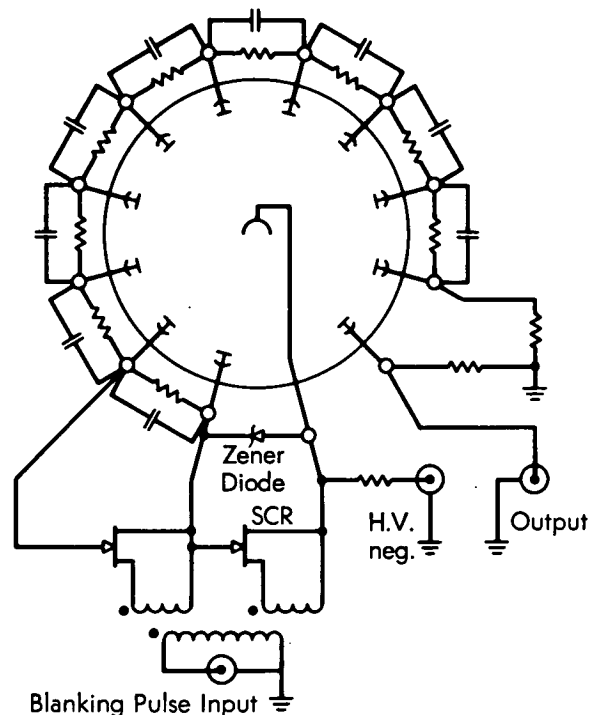

from its previous value (ordinarily between 100 to 400 volts) to less than about 3 volts. Now, photoelectrons emitted by the photocathode are not accelerated toward the first dynode, and the few that manage to arrive have insufficient energy to cause reemission from this dynode.

(continued overleaf)

The circuit shown in the diagram provides for the short-circuiting of two stages to provide double assurance that no electrons propagate to the subsequent stages which are still at full accelerating potential. Measurement of the voltage between the photocathode and the second dynode indicates that sensitivity to light is eliminated within 5 microseconds after application of the blanking pulse; however, the sudden increase in voltage across the last dynode appears as a 2-millisecond spike at the output (regardless of illumination). The increase in power supply current resulting from the shorting of two stages in the dynode resistor chain is only about 20 percent; thus, a special power supply is not required. The pulse required to trigger the blanking circuit is about 20 volts, and it can be conveniently obtained from the positive gate-pulse of most oscilloscopes.

Note:

No additional documentation is available. Specific questions, however, may be directed to:

Technology Utilization Officer
Ames Research Center
Moffett Field, California 94035
Reference: B72-10561

Patent status:

Inquiries concerning rights for the commercial use of this invention should be addressed to:

NASA Patent Counsel
Mail Code 200-11A
Ames Research Center
Moffett Field, California 94035

Source: James O. McClenahan
Ames Research Center
(ARC-10593)