

NASA TECH BRIEF

Marshall Space Flight Center



NASA Tech Briefs announce new technology derived from the U.S. space program. They are issued to encourage commercial application. Tech Briefs are available on a subscription basis from the National Technical Information Service, Springfield, Virginia 22151. Requests for individual copies or questions relating to the Tech Brief program may be directed to the Technology Utilization Office, NASA, Code KT, Washington, D.C. 20546.

Tandem Steerable Running Gear

Development of transportation equipment to handle flight vehicle components used in the Skylab Program was necessary in order to successfully maneuver the units through narrow factory aisles as well as to transport them over public highways and access roads. The prime design considerations relative to the transporting capabilities of the units were their ability to negotiate the tight turns within the factory area, both inter-plant and intra-plant, and their ability to adequately distribute

Tandem-axled, articulately steered, running-gear assemblies were designed that are capable of carrying a 18,000 kg (40,000 lb) load on each pair of axles with a 11.6-m (38 ft) turning radius. The assemblies included standard pneumatic brake systems which are compatible with commercial truck pneumatic brake systems and which have been verified in compliance with ICC regulations regarding braking capability. The gear assemblies utilize a large majority of commercially available parts,

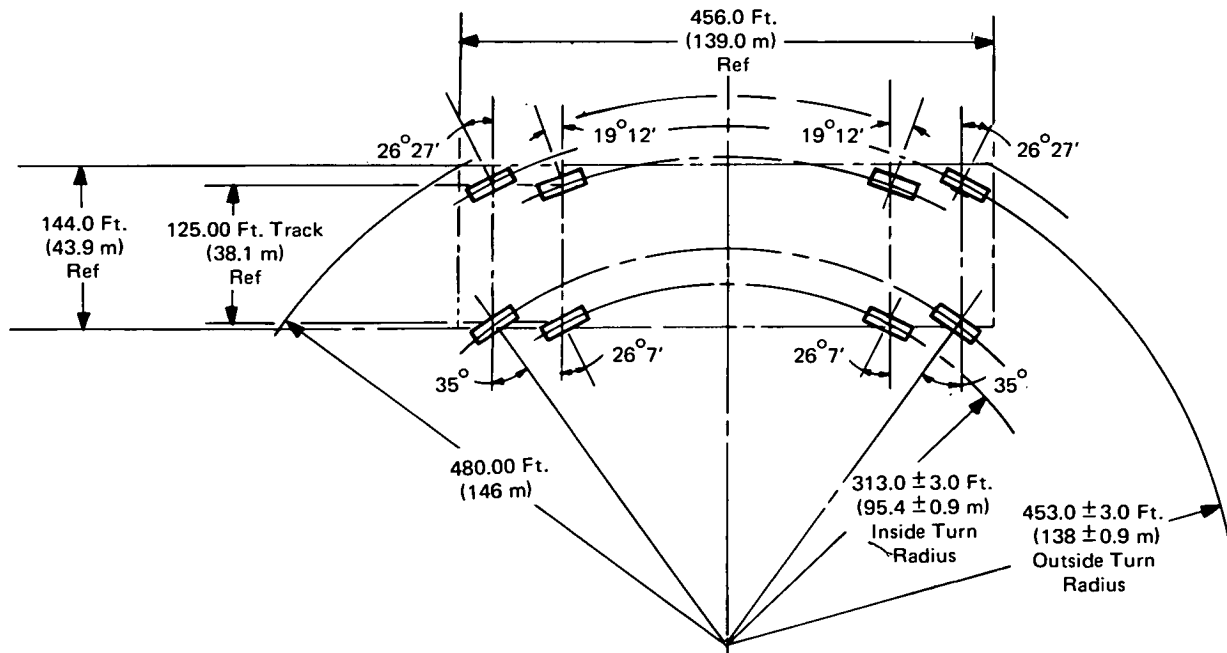

Typical Steering Diagram No Scale

the large, gross transporter loads over the factory floors and aisles as well as highways and access roads. Compliance with state and federal highways standards required, as a minimum, a tandem-axle system at each end of the transporter plus a tandem-axle suspension system that would assure equal load distribution by all axles.

use commercial wheels and tires, and have been packaged to be readily dismantled as a unit and reinstalled on other trailer frames. The assemblies incorporate load equalizing beam assemblies to equally distribute the load to each axle. Interconnecting linkages are installed between the wheel assemblies mounted on the equalizing

(continued overleaf)

beam assembly so that when the steering tow bar is actuated in either direction, each wheel assembly is moved in proportion to its radial position from a pre-determined common turning point.

Notes:

1. Information concerning this innovation may be of interest to manufacturers and users of vehicles carrying large loads, e.g. trailers, as well as the truck and automotive industry.
2. Requests for further information may be directed to:
Technology Utilization Officer
Marshall Space Flight Center
Code A&TS-TU
Huntsville, Alabama 35812
Reference: B72-10499

Patent status:

Inquiries concerning rights for the commercial use of this invention should be addressed to:

Technology Utilization Office
Marshall Space Flight Center
Code A&TS-PAT
Huntsville, Alabama 35812

Source: O. J. Fincannon, and D. L. Glenn of
McDonnell Douglas Corporation
under contract to
Marshall Space Flight Center
(MFS-22012)