

August 1972

B72-10484

NASA TECH BRIEF

Lewis Research Center



NASA Tech Briefs announce new technology derived from the U.S. space program. They are issued to encourage commercial application. Tech Briefs are available on a subscription basis from the National Technical Information Service, Springfield, Virginia 22151. Requests for individual copies or questions relating to the Tech Brief program may be directed to the Technology Utilization Office, NASA, Code KT, Washington, D.C. 20546.

Slot Configuration for Axial-Flow Turbomachinery Blades

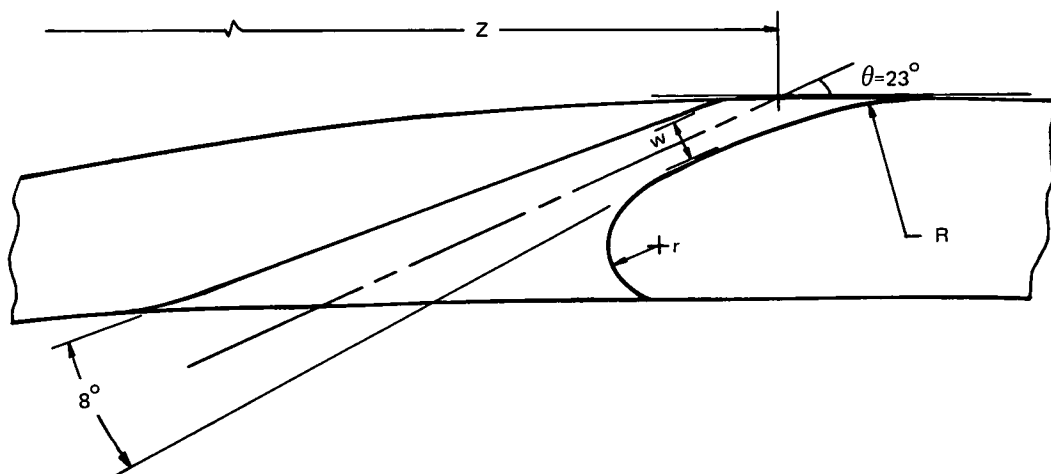

Figure 1.

A slot, machined to provide a flow path between the pressure and suction surfaces, has been found to improve the range of operation and flow turning characteristics of hydrofoils arranged in various cascade configurations, simulating axial-flow blading geometries. Although slots have often been proposed to extend compressor blade operating ranges, in practice the slots have seldom achieved the objectives of increasing either the operating range or the flow turning angles. A slot geometry achieving these objectives, in a two-dimensional cascade, has recently been developed.

The 8-degree converging-wall slot geometry, shown in Figure 1, uses a 16.7-percent chord radius (R) at the slot exit on the suction surface, a 1.67-percent chord slot lip radius (r) at the slot inlet on the pressure surface, a 1.57-percent chord slot width (w) at the suction surface, and the slot centerline was located at the 45 percent chordal station (Z) with an angle of 23° between the slot centerline and the tangent to the blade surface. Blading which uses this slot geometry was tested in a

two-dimensional cascade. The improvements in turning angle (θ) and loss coefficient (\bar{w}) performance of this slot with the indicated cascade configuration are shown in Figure 2. The results show that the slotted blade turning angles increase linearly with increasing incidence angle. Slotted blade loss coefficients, although higher than those for the unslotted blade within the minimum loss region, are significantly lower at higher incidence angles. Thus, these slotted blades have a greater range of incidence angle operation. The improvements in performance obtained from the slots appear to be most significant when the slotted blades are arranged in low solidity cascades.

Notes:

1. The following documentation may be obtained from:
National Technical Information Service
Springfield, Virginia 22151
Single document price \$11.50
(or microfiche \$0.95)

(continued overleaf)

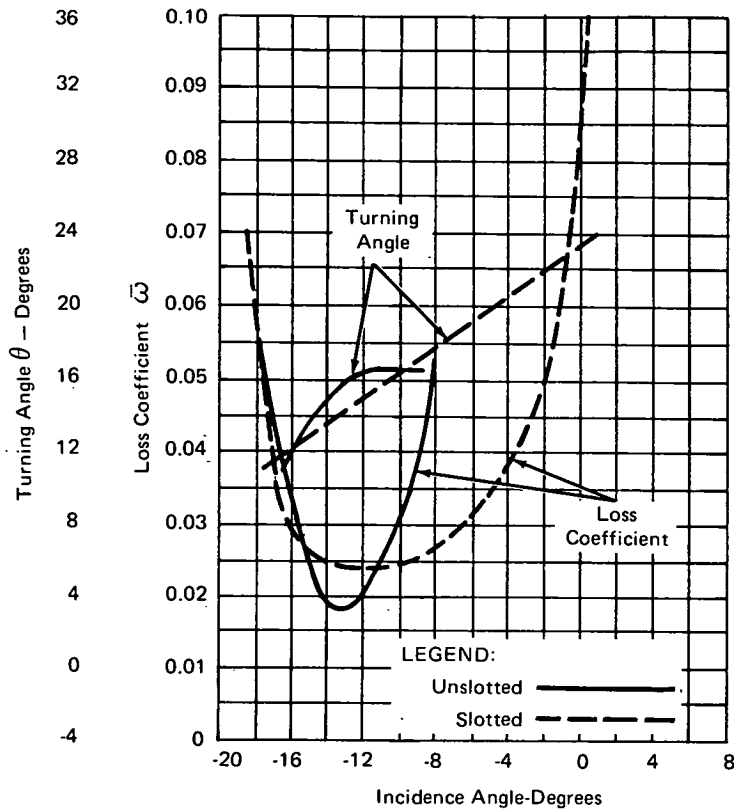

Figure 2.

Reference: NASA CR-72870 (N72-24366),
 Systematic Two-Dimensional Cascade Tests,
 Vol. 3 - Slotted Double Circular-Arc Hydrofoils

Patent status:

No patent action is contemplated by NASA.

2. Technical questions may be directed to:
 Technology Utilization Officer
 Lewis Research Center
 21000 Brookpark Road
 Cleveland, Ohio 44135
 Reference: B72-10484

Source: W. E. Taylor of
 United Aircraft Research Labs.
 under contract to
 Lewis Research Center
 (LEW-11572)