

NASA TECH BRIEF

Marshall Space Flight Center



NASA Tech Briefs announce new technology derived from the U.S. space program. They are issued to encourage commercial application. Tech Briefs are available on a subscription basis from the National Technical Information Service, Springfield, Virginia 22151. Requests for individual copies or questions relating to the Tech Brief program may be directed to the Technology Utilization Office, NASA, Code KT, Washington, D.C. 20546.

Constant Tension Device For Gravity Simulation

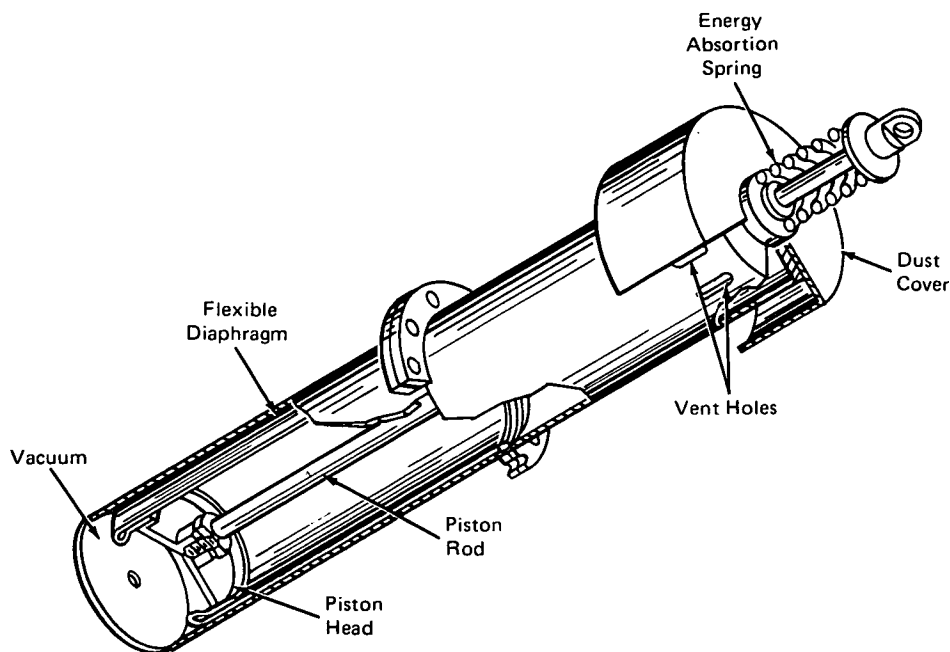

Constant Force Cylinder Assembly – Cutaway View

Figure 1

A technique used to simulate the gravitational pull of the lunar surface may have application in supportive therapy. The device (see Figure 1) applies a constant tension or force on a cable while allowing relative motion along the principal vertical axis of the cable. The cylinder which applies the constant tension consists of two cylinder halves flanged at one end and closed at the other, a piston head, a piston rod, and a pressure separation flexible diaphragm (see Figure 2). The vacuum in the vacuum chamber causes the atmospheric pressure on the opposite side of the diaphragm to develop a constant force on the piston rod when the rod is held at the extreme end. The same force is prevalent regardless of piston position and is a function of the differential pressure across the piston and the effective cross sectional area. By con-

trolling the vacuum inside the vacuum chamber the rod tension is controlled.

A rapid change in chamber volume does not significantly change the chamber pressure. Since the atmospheric chamber is vented to the atmosphere through large vent holes, the chamber can exhaust and inhale as required by the piston stroke without compressing or expanding. The vacuum chamber pressure changes will also be small since the number of gas molecules in the closed chamber is at a minimum under full vacuum conditions. Tension value is controlled by a vacuum valve which regulates the desired vacuum in the chamber. Operating characteristics of the device vary depending upon cylinder size, differential pressure, and diaphragm stiffness and material.

(continued overleaf)

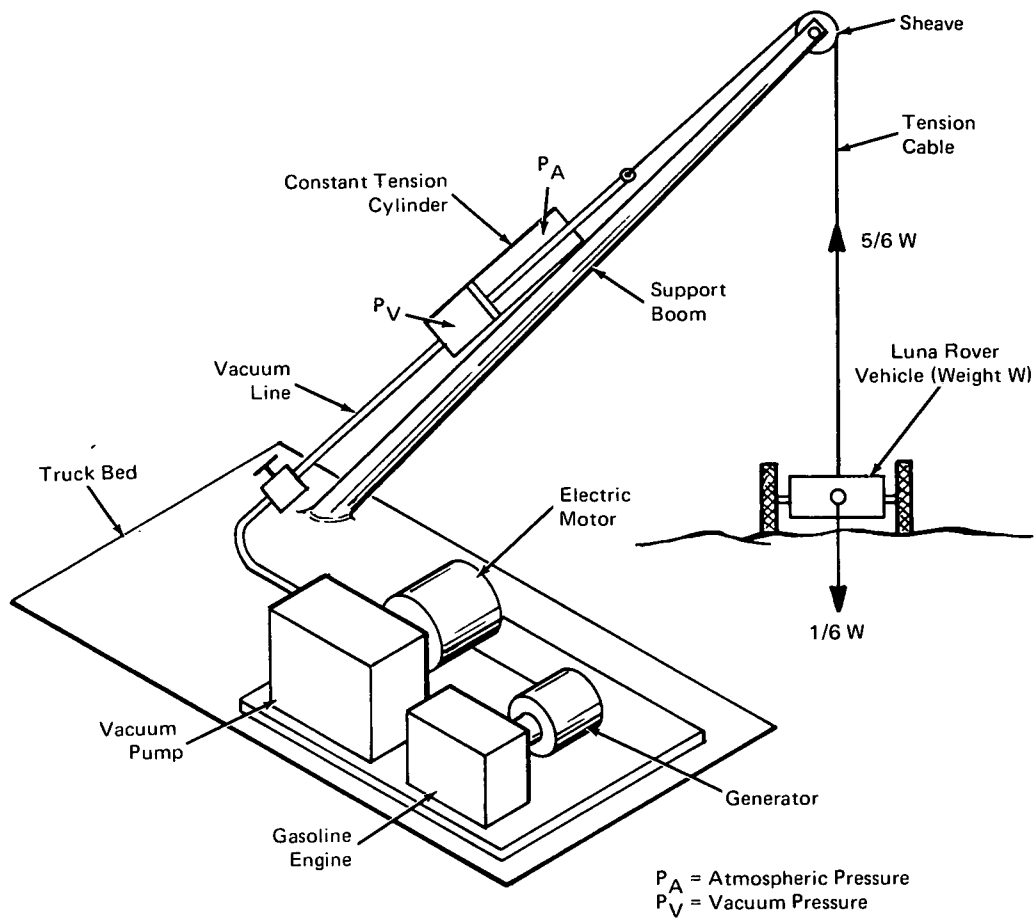

Figure 2

Notes:

1. Information concerning this innovation may be of interest to designers and manufacturers of equipment used in supportive therapy.
2. Requests for further information may be directed to:
 Technology Utilization Officer
 Marshall Space Flight Center
 Code A&TS-TU
 Huntsville, Alabama 35812
 Reference: B72-10466

Patent status:

No patent action is contemplated by NASA.

Source: W. F. Orłowski of
 Sperry Rand Corporation
 under contract to
 Marshall Space Flight Center
 (MFS-21618)