

NASA TECH BRIEF

NASA Pasadena Office



NASA Tech Briefs announce new technology derived from the U.S. space program. They are issued to encourage commercial application. Tech Briefs are available on a subscription basis from the National Technical Information Service, Springfield, Virginia 22151. Requests for individual copies or questions relating to the Tech Brief program may be directed to the Technology Utilization Office, NASA, Code KT, Washington, D.C. 20546.

Planetary Rock Corer and Drill Concepts

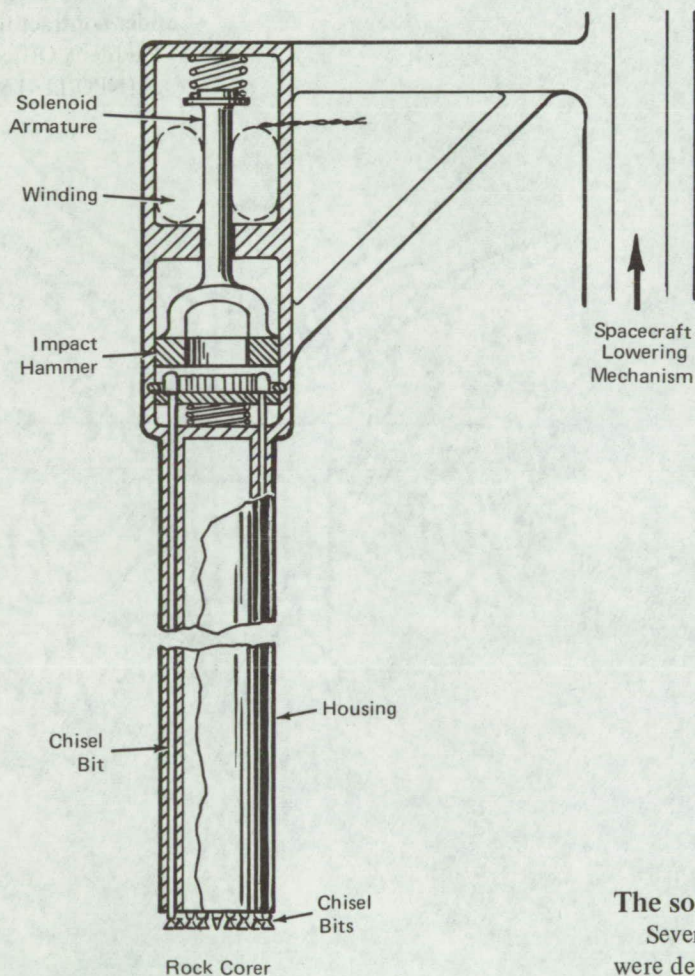

Figure 1.

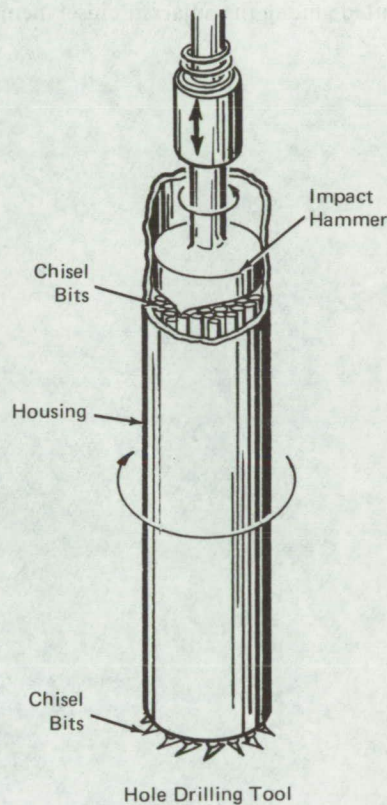

Figure 2.

The solution:

Several planetary rock corers and drill design concepts were developed for such applications.

How it's done:

The rock corer, shown in Figure 1, is a rotary-impact multiple-chisel-bit trepan. The chisel bits are supported and guided within the housing which rotates in one direction; the impact hammer rotates in the opposite direction. The hammer can be designed to strike all the chisel members simultaneously or diametrically opposite

The problem:

To obtain subsurface rock samples in future planetary explorations, a highly efficient and versatile tool is needed. The tool is to be designed for unmanned space vehicles.

(continued overleaf)

chisel pairs sequentially. Impact can be provided by a solenoid actuator and a return spring or by some other equivalent mechanical means. For a more effective local fracture of the rock, the adjacent bits are arranged at different angles. In addition, to minimize the required power and to increase the impact frequency rate, the bits are long and slim-sectioned. A conveyor arrangement built in among the chisel members removes the fractured material and prevents clogging of the tool.

The hole drilling tool, as shown in Figure 2, is similar in construction to the trepan. In this tool, however, the chisel members are not mounted along the perimeter only but fill the housing. Again, helical fracture material removing conveyors may be properly distributed among the adjacent chisel members.

Note:

Requests for further information may be directed to:
Technology Utilization Officer
NASA Pasadena Office
4800 Oak Grove Drive
Pasadena, California 91103
Reference: TSP72-10398

Patent status:

No patent action is contemplated by NASA.

Source: R. E. Imus of
Jet Propulsion Laboratory of
California Institute of Technology
under contract to
NASA Pasadena Office
(NPO-11416)