

# NASA TECH BRIEF

## NASA Pasadena Office



NASA Tech Briefs announce new technology derived from the U.S. space program. They are issued to encourage commercial application. Tech Briefs are available on a subscription basis from the National Technical Information Service, Springfield, Virginia 22151. Requests for individual copies or questions relating to the Tech Brief program may be directed to the Technology Utilization Office, NASA, Code KT, Washington, D.C. 20546.

### Simple Non-destructive Tests for Electroexplosive Devices

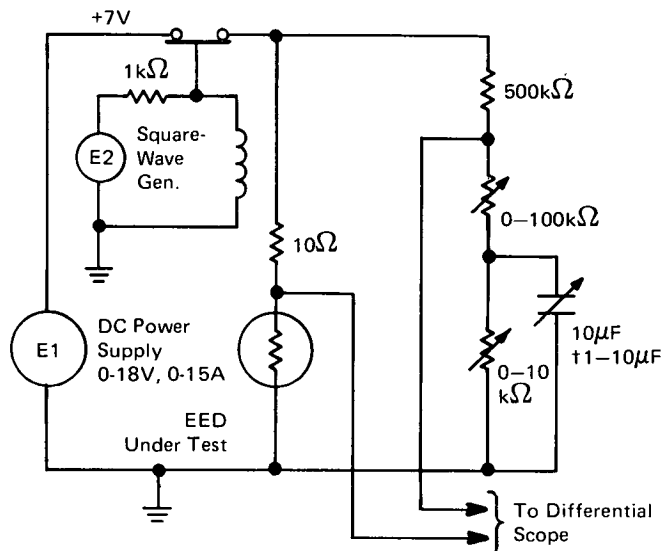

Figure 1. Transient Pulse Circuitry

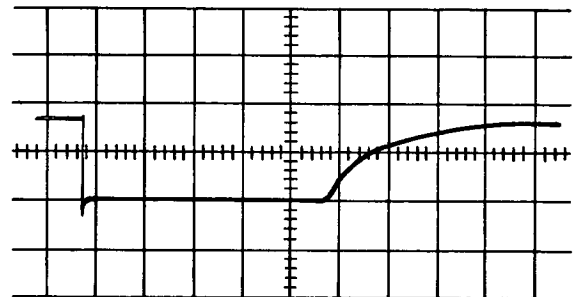

Figure 2. Normal Display 5mV/cm

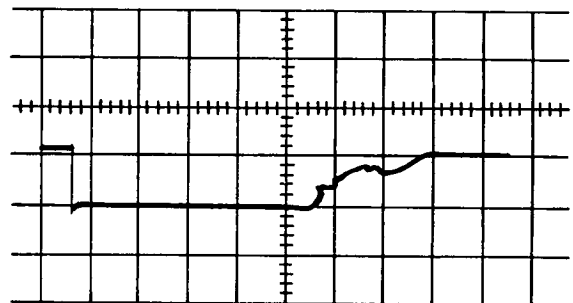

Figure 3. Abnormal Display 5mV/10ms/cm

#### The problem:

There is a need to non-destructively test electroexplosive devices (EED's) quickly, efficiently, and safely. Effective non-destructive test techniques that measure the quality and expected performance of such devices must yield meaningful data and not cause degradation as a result of the measurement. The techniques should accommodate 1-A/1-W no-fire devices in a simplified test procedure that will detect abnormalities and defects which could eventually result in a failure.

#### The solution:

By pulsing an electroexplosive device with a safe level of current and by examining the resistance variation of the bridgewire, it is possible to define the electrothermal behavior of the bridgewire-explosive interface. The bridgewire, acting as a resistance thermometer, provides a signal which describes the average wire temperature and the heat sinking to the explosive and enclosure.

#### How it's done:

The device to be tested is connected as one arm of a Wheatstone bridge circuit, as shown in the illustration. A square wave current pulse is applied to the bridge circuit by a fast acting mercury switch driven by square-wave voltage source E2. The switch, operating at 10 Hz, closes for 50 milliseconds and opens (to allow for cooling) for 50 milliseconds. A safe test current flows through the bridgewire in the device under test. As the bridgewire heats, the bridge circuit unbalances and provides a heating curve which is displayed on the oscilloscope screen. During the cooling cycle there is no signal output since the bridge circuit is passive. A few simple manipulations of the bridge circuit displays on the screen will, when properly interpreted, indicate the cold resistance, the thermal time constant, and the heat loss factor of the device under test.

(continued overleaf)

The normal heating cycle is displayed on the oscilloscope as a smooth curve in the form of a simple exponential rise. Any deviation from this ideal shape is indicative of abnormalities such as poor bridgewire weld connections, current crowding, or low explosive compaction pressure. These abnormalities obscure the normal heating cycle and result in very erratic signals. Although the details of the fault may not be fully understood, these odd responses indicate the possibility of failure.

A self-balancing Wheatstone bridge may also be used for testing. This technique yields a parameter indicative of the thermal coupling of the bridgewire to the explosive. These measurements compare favorably with values based on transient pulse testing.

A self-balancing bridge is a circuit arranged to automatically maintain a Wheatstone bridge near balance. If one element of the bridge can heat up (the squib under test) and bring the bridge to a condition near balance, a state of sustained oscillation can be maintained. If a thermally insensitive resistor is substituted for the test item, the amount of adjustment necessary to rebalance the bridge gives an indication of the power-resistance relationship of the unit under test.

The self-balancing bridge can be used as a non-destructive inspection tool. All units should behave in a normal manner up to levels specified by the test (i.e., 1 watt in the case of 1-A/1-W no-fire devices). Any instabilities should be treated with suspicion and the power sensitivity (in terms of watts per unit change in resistance), can be used as a meaningful classification parameter.

Another testing technique for electroexplosive devices is the thermal follow display method. This technique is

used to determine electrical and thermal performance. A self-balancing bridge is used and the output appears on an oscilloscope screen as a Lissajous phase display figure. Such a method could be used as an incoming inspection tool for 1-A/1-W devices to indicate cold resistance, weld instabilities, and qualitative thermal behavior. The last would be indicated by the area of the trace at a given excitation level. A normal display or wax crayon outline on the scope face could be used as a basis of comparison.

**Note:**

Requests for further information may be directed to:  
Technology Utilization Officer  
NASA Pasadena Office  
4800 Oak Grove Drive  
Pasadena, California 91103  
Reference: B72-10315

**Patent status:**

Inquiries about obtaining rights for the commercial use of this invention may be made to:

Patent Counsel  
NASA Pasadena Office  
4800 Oak Grove Drive  
Pasadena, California 91103

Source: L. A. Rosenthal of  
Rutgers University and  
Vincent J. Menichelli of  
Caltech/JPL  
under contract to  
NASA Pasadena Office  
(NPO-11563)