



AEC-NASA TECH BRIEF

Lawrence Berkeley Laboratory



AEC-NASA Tech Briefs announce new technology derived from the research and development program of the U.S. AEC or from AEC-NASA interagency efforts. They are issued to encourage commercial application. Tech Briefs are available on a subscription basis from the National Technical Information Service, Springfield, Virginia 22151. Requests for individual copies or questions relating to the Tech Brief program may be directed to the Technology Utilization Office, NASA, Code KT, Washington, D.C. 20546.

A Sensitive Image Intensifier Which Uses Inert Gas

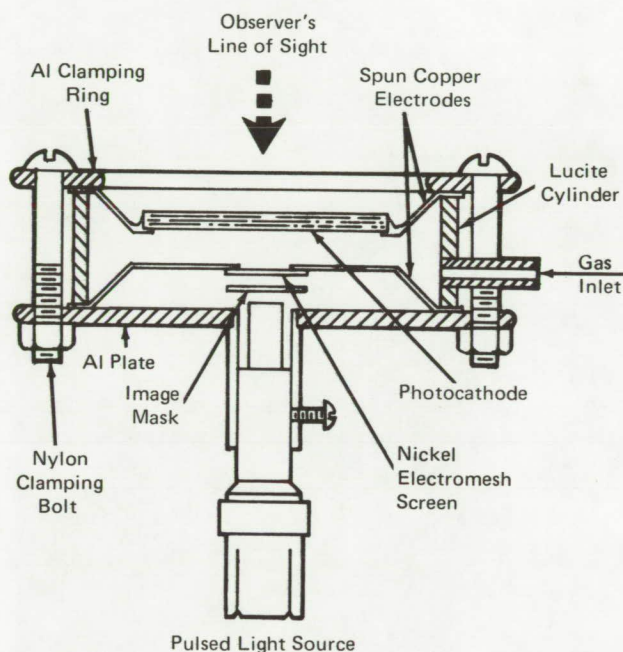

copper electrodes which are spaced 1 cm apart to allow the electron avalanches to fully form without excessive pulse voltages. Toward the edges, the electrodes flare out to a 3-cm spacing to prevent electrical breakdown along the lucite cylinder walls. The aluminum plate and the clamping ring are held together with nylon insulating bolts.

A 4.5-cm (1.75 in) hole is cut in the upper electrode, and a 5-cm conducting glass disc is soldered in place to serve as a photocathode and an optical window. The glass is a Pyrex disc 3.2-mm thick which is coated with a thin transparent SnO_2 coating. Transmittance through this cathode is 85%. A 1.25-cm (0.5-in) hole is cut in the lower electrode to accommodate a nickel screen that prevents alteration of the electrical properties of the plate. This mesh has 25 holes/mm and is 80% transparent.

Experiments with this device used a pulse generating system which applied 30-kV/cm electric field pulses of 8-ns duration across a light amplifying chamber.

In addition helium, neon, and argon gases were tried to estimate their efficiencies.

Results of these tests showed that the developed intensifier produces up to 10^9 detectable photons from a single avalanche and, thus, provides an optical gain of 2×10^7 . At this gain, the avalanche diameter of 0.5mm places an upper limit on resolution. At lower gains, the avalanche diameter is less than 0.1mm.

The problem:

As a result of recent developments, many image intensifier configurations exist that have sufficient gain to photographically record an image of a single electron leaving a photocathode. Although sensitive, these devices require improved efficiency and resolution.

The solution:

An intensifier was developed which uses an inert gas in its cavity. The device provides an estimated optical gain of 2×10^7 .

How it's done:

A cross section of the developed image intensifier is shown in the figure. The device uses two 5-cm spun

Note:

Requests for further information may be directed to:

Mr. Robert J. Morris
 Technical Information Division
 Lawrence Berkeley Laboratory
 University of California
 Berkeley, California 94720
 Reference: B72-10312

(continued overleaf)

Patent status:

Inquiries concerning rights for commercial use of this invention may be made to:

Chief

California Patent Group

U.S. Atomic Energy Commission

P.O. Box 808

Livermore, California 94550

Source: H. M. Miller and
Q. A. Kerns of
University of California
under contract to
Lawrence Berkeley Laboratory
(LRL-10024)