

# NASA TECH BRIEF

## Ames Research Center



NASA Tech Briefs announce new technology derived from the U.S. space program. They are issued to encourage commercial application. Tech Briefs are available on a subscription basis from the National Technical Information Service, Springfield, Virginia 22151. Requests for individual copies or questions relating to the Tech Brief program may be directed to the Technology Utilization Office, NASA, Code KT, Washington, D.C. 20546.

### Miniature High Pressure Regulator

#### The problem:

To design a small gas regulator capable of supplying 15–100 psig gas pressure from a source at 3000 to 4000 psig, i.e., a gas pressure of 205–791 kN/m<sup>2</sup> from a source at 20.8 to 27.7 MN/m<sup>2</sup>.

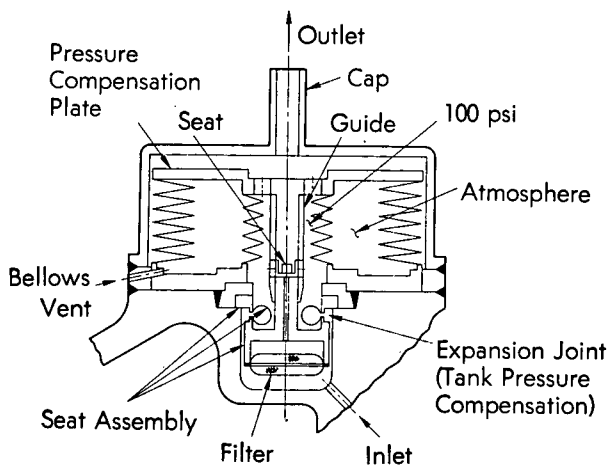

#### The solution:

Utilize metal bellows in place of bulky diaphragms, sliding seals, and springs generally employed in regulators.

#### How it's done:

The differential area of the concentric bellows shown in the diagram is exposed to the downstream pressure. Initially, gas supplied to the inlet flows through the open poppet and increases the pressure in the downstream volume until it reaches the regulation pressure which is of sufficient force to close the

poppet and shut off the high-pressure gas. Variations in supply pressure are accommodated by an expansion joint which retracts and enlarges the poppet area progressively so that the pressure drop across the seat is reduced for a given poppet position, thus maintaining constant flow. The pressure compensator plate moves so as to maintain a constant differential pressure between ambient and the downstream volume.

The small size of the regulator permits the use of bellows with a stiffness adequate for supplying the required spring rate without recourse to additional springs. Since all bellows are exposed only to downstream pressures, distortion of the effective area of bellows seals by high pressure is avoided. Stability of operation is assured by appropriately-sized flow passages through the bellows' upper plates. Sudden changes in flow demand, created by either opening or closing downstream solenoids, result in a transient pressure differential across the plates which aids the movement of the poppet as required. This action results in faster response and, consequently, lower lock-up pressures.

The only metal-to-metal contact in the regulator is the bellows plate and the poppet seat. The poppet seat is a soft metal stop which prevents the extrusion of the elastomeric poppet seal under the initial high differential pressure.

#### Note:

No additional documentation is available. Specific questions, however, may be directed to:

Technology Utilization Officer  
Ames Research Center  
Moffett Field, California 94035  
Reference: B72-10211

(continued overleaf)

**Patent status:**

No patent action is contemplated by NASA.

Source: Harvey Weston Wright, Jr. and  
William Shu-Shin Wang of  
TRW Systems Group, TRW Inc.  
under contract to  
Ames Research Center  
(ARC-10428)