

NASA TECH BRIEF

Ames Research Center



NASA Tech Briefs announce new technology derived from the U.S. space program. They are issued to encourage commercial application. Tech Briefs are available on a subscription basis from the National Technical Information Service, Springfield, Virginia 22151. Requests for individual copies or questions relating to the Tech Brief program may be directed to the Technology Utilization Office, NASA, Code KT, Washington, D.C. 20546.

Cine Recording Ophthalmoscope

Retinal cinephotography has been used to study the changes in retinal circulation patterns which occur in high gravity fields or in the large centrifugal force fields obtained by spinning human beings in

without need for the camera operator to be aboard the centrifuge but also permitted immediate observation of dynamic changes in retinal circulation by a closed-circuit television loop.

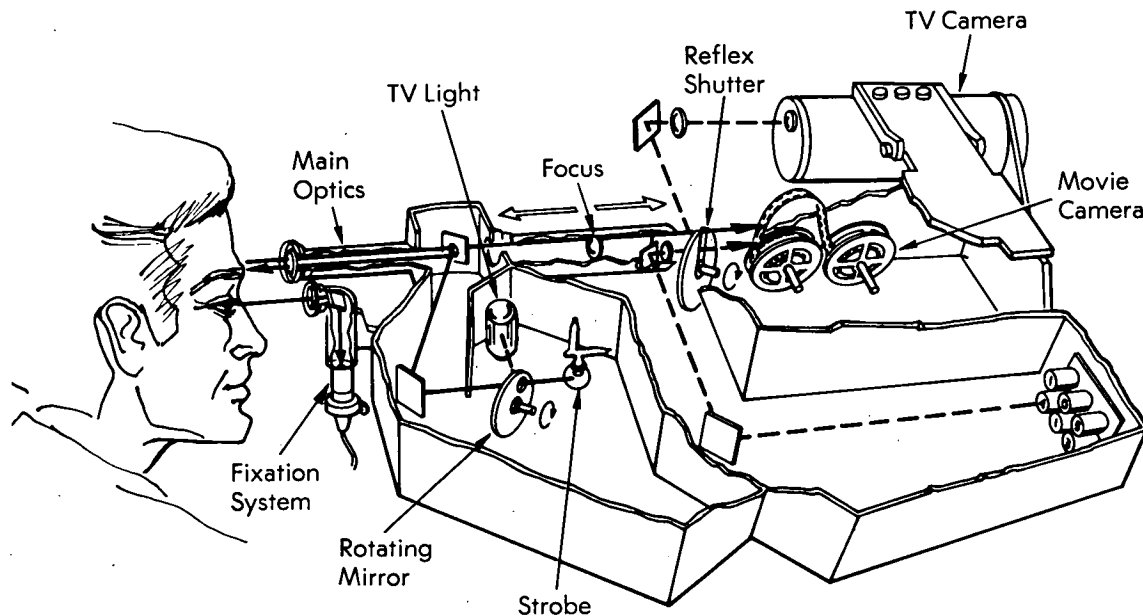

centrifuges. In the past, cinephotographic exposures were made by a camera operator who was protected by a G-suit while he rode along in the centrifuge. Since the camera operator was exposed to the same forces as the subject, the level of gravitational stress was limited and critical focusing adjustments were difficult, if not impossible, to perform above centrifugal blackout.

A remotely operable cine recording ophthalmoscope system was developed which not only provided more accurate photographic recording during acceleration

The camera system consists of three separate units: (1) The main camera, which is a modified fundus camera and includes both direct viewing, remote television viewing, and permanent recording either on 35-mm film or on video tape; (2) The remote control unit which provides adjustment of focus on the subject's fundus, a shift of the camera in either the x, y, or z axes, and the movement of a fixation light system that allows viewing of various parts of the retina while the subject is being imposed to the same stress environment; (3) The strobe power supply unit.

(continued overleaf)

The main optics used to focus light on the retina are those of a Zeiss fundus camera which was modified to provide remote control of fine focus and selection of filters for special studies. The rear element of the lens system was remounted and equipped with a motor drive for normal and fine focusing (total of 3.8 cm of travel forward and backward). The filter system was altered to accommodate six filters which could be rotated into position with a motorized drive; there are two neutral density filters, a clear glass filter for use with color film, two green filters (minus red), and a blue interference filter for use in fluorescein studies. With the resolution provided by the lens system, arterioles and venules are clearly visible on film.

A 250-watt incandescent bulb is used for illumination during initial focusing through an eyepiece, and, when the television camera is in position, for closed loop monitoring on the TV screen. A xenon flash tube provides the high-intensity illumination required for cinephotography. Light from the strobe flash passes through the slotted rotating mirror which is synchronized with the camera shutter. During completion of the revolution, the rotating mirror reflects the light of the incandescent bulb and provides illumination for TV observation.

The fixation light unit contains a cathode ray tube and a lens assembly which collimates the light of a dot that moves on the tube face; it can be mounted on either the left or right of the camera lens for positioning the eye not being photographed.

The 35-mm reflex camera has a capacity of 122 m of film. It is driven by a synchronous motor at rates of 24, 30, or 48 frames per second. The reflex shutter permits entrance of light only when the film is held stationary in the aperture plate assembly. The shutter

is a balanced true-reflex type with a mirror surface set at an angle from the camera body so that the retinal image may be relayed to the closed circuit TV system.

The ophthalmoscope functions at stresses up to 10G, and has been used successfully in more than fifty separate centrifuge experiments. It has also been used in the laboratory for a variety of experiments including fluorescein studies and dynamometry sequences.

References:

1. Cheek, R. J.; Leverett, Jr., S. D.; Holden, G. R.; Fitzgerald, J.; and Bailey, Jr., P. F.: New Cine Recording Ophthalmoscope with Television Monitoring Capability for Use in Aerospace Research. *Aerospace Medicine*, vol. 40 no. 12, page 1312, 1969.
2. Leverett, Jr., S. D.; Bailey, Jr., P. F.; Holden, G. R.; and Cheek, R. J.: Fundus Cinephotography During Gravitational Stress. *Arch. Ophthalm.*, vol. 83, page 223, 1970.

Note:

Requests for additional information may be directed to:

Technology Utilization Officer
Ames Research Center
Moffett Field, California 94035
Reference: TSP 72-10189

Patent status:

No patent action is contemplated by NASA.

Source: James W. Fitzgerald
Ames Research Center
(ARC-10399)