

NASA TECH BRIEF

Ames Research Center



NASA Tech Briefs announce new technology derived from the U.S. space program. They are issued to encourage commercial application. Tech Briefs are available on a subscription basis from the National Technical Information Service, Springfield, Virginia 22151. Requests for individual copies or questions relating to the Tech Brief program may be directed to the Technology Utilization Office, NASA, Code KT, Washington, D.C. 20546.

Illumination Control System

The problem:

The experiment on the growth of Arabidopsis that is to be performed during space flight requires exposure to a constant intensity of light for 21 days.

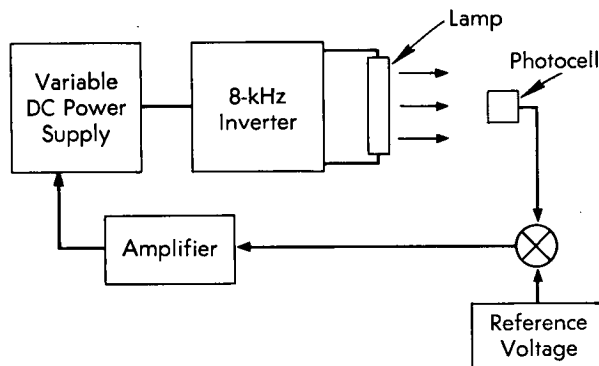

Wide-spectrum fluorescent lamps are to be used in this experiment, but since it is known that their luminous output decreases continuously, it is necessary to provide an illumination control system.

The solution:

The luminous output is monitored by a photocell which controls the power supplied to the lamp.

How it's done:

A variable DC supply powers an 8-kHz inverter which operates the lamp. The light output is mea-

sured by a photocell and its output is compared to a reference voltage corresponding to the specified light output. An error signal generated in this way is amplified and used to control the output of the DC power supply. Consequently, the voltage to the lamp is controlled so that the light output remains at a fixed value. As the lamp output decreases with use, the supply voltage is automatically increased to bring the light output back to normal.

Notes:

1. Arabidopsis is a small genus of herbs of the mustard family.
2. No additional documentation is available. Specific questions, however, may be directed to:

Technology Utilization Officer
Ames Research Center
Moffett Field, California 94035
Reference: B

Patent status:

No patent action is contemplated by NASA.

Source: Carl Beckman of
General Technical Services, Inc.
under contract to
Ames Research Center
(ARC-10527)

Category 02