

# NASA TECH BRIEF

## NASA Pasadena Office



NASA Tech Briefs announce new technology derived from the U.S. space program. They are issued to encourage commercial application. Tech Briefs are available on a subscription basis from the National Technical Information Service, Springfield, Virginia 22151. Requests for individual copies or questions relating to the Tech Brief program may be directed to the Technology Utilization Office, NASA, Code KT, Washington, D.C. 20546.

### Crystal-Controlled Multivibrator

#### The problem:

To design a crystal oscillator which has the frequency and symmetry stability demanded of system-clock-generators used in spacecraft data systems.

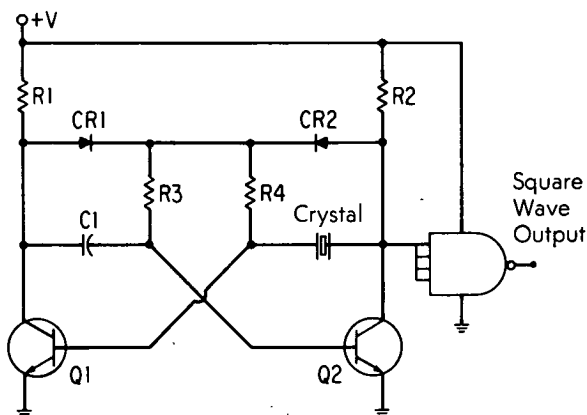

#### The solution:

A simple multivibrator in which a crystal replaces the timing capacitor; latch-up is prevented by diodes and a capacitor.

#### How it's done:

The circuit shown in the diagram is a symmetrical free-running multivibrator with one of its timing capacitors replaced by a crystal which operates in a series-resonant mode. The circuit may be set up by constructing a multivibrator which runs at a frequency slower than it is to be used, and replacing a capacitor with a series-resonant crystal. The crystal is used to drive Q-1 with a 50-percent duty cycle at the resonant frequency, where it presents a low im-

pedance to the base of Q-1. Coarse timing capacitor C-1 is used as in a free-running multivibrator; it must be large enough to hold transistor Q-2 nonconducting for a half cycle. Its principle function is to start the oscillator at the desired harmonic of the crystal frequency (normally, the fundamental). Increasing the size of C-1 will not affect the frequency or symmetry because this function is controlled by the crystal; therefore, the circuit is not sensitive to the time constant established by C-1.

The output taken from the collector of Q-2 has a nearly square form because the crystal limits  $di/dt$  at the base of Q-1 to a sinusoidal zero-crossing. Transistor Q-2 provides further amplification to ensure a square waveform. Two resistors and two diodes could be added to improve the squareness of the waveform; both sides of the waveform (or phases) may be obtained by this expedient for use in timing functions.

The symmetrical configuration of the oscillator minimizes generation of noise in power supply lines because both states of the multivibrator drain approximately the same power supply current. Transients on the power supply lines during switching are minimized as usual by use of high-frequency ( $0.01 \mu\text{f}$ ) and low-frequency ( $1.0 \mu\text{f}$ ) bypass capacitors installed across the supply lines near each oscillator.

A circuit beta of approximately 10 is used to assure saturation over extreme transistor degradation; gold-doped high-speed transistors are used because of their low charge-storage time, and they are run at a high collector current of about 9 mA to provide a low pull-up resistance at the gate input and thus a squarer risetime waveform to the gate.

(continued overleaf)

For this type of oscillator, the impedance of the series-resonant crystal must be less than about 1000 ohms; high loop voltage-gain is required for crystals of higher impedance.

Startup of the oscillator is assured by diodes CR-1 and CR-2, which supply base-drive to either transistor from the highest voltage collector and prevent the only possible mechanism for latch-up, i.e., both transistors saturated. The oscillator will not latch-up with either transistor off or both off because there is no DC supply which could hold the transistors at cutoff. When both transistors are active, either one must drive to a quasi-stable state or both must proceed towards saturation because the open-loop gain is much greater than one. When both transistors tend to saturate, their collectors go low and their base drives are removed; however, this condition cannot exist for long because both transistors operate about their noise region. As soon as one transistor is on a little harder than the other, regeneration will take the circuit into oscillation.

The minimum voltage for operation is just enough to forward-bias two junctions. At this voltage, the oscillator maintains frequency and symmetry.

**Note:**

Requests for further information may be directed to:

Technology Utilization Officer  
NASA Pasadena Office  
4800 Oak Grove Drive  
Pasadena, California 91103  
Reference: TSP 72-10155

**Patent status:**

NASA has decided not to apply for a patent.

Source: Robert C. Schober of  
Caltech/JPL  
under contract to  
NASA Pasadena Office  
(NPO-11627)