

# NASA TECH BRIEF

## Lewis Research Center



NASA Tech Briefs announce new technology derived from the U.S. space program. They are issued to encourage commercial application. Tech Briefs are available on a subscription basis from the National Technical Information Service, Springfield, Virginia 22151. Requests for individual copies or questions relating to the Tech Brief program may be directed to the Technology Utilization Office, NASA, Code KT, Washington, D.C. 20546.

### A Reliable Liquid Helium Level Detector

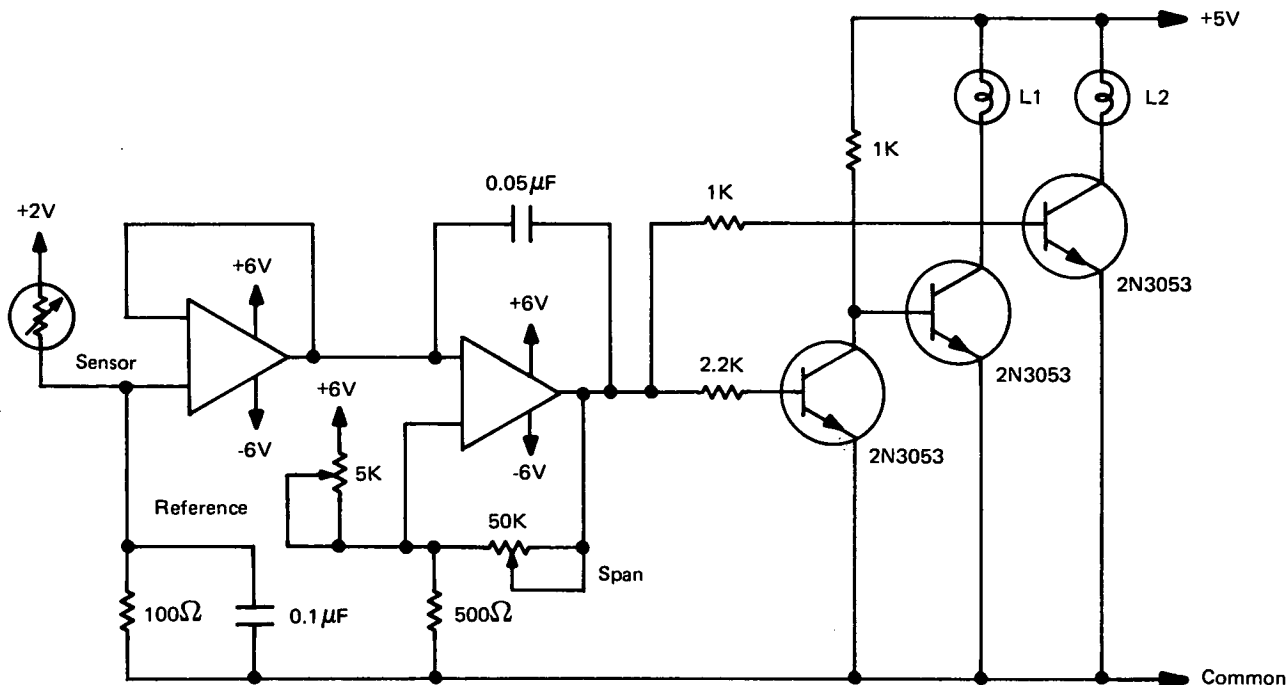

Figure 1. Circuit schematic of the level detector and indicator system.

A liquid helium level detector and indicator system has been developed which can operate reliably over a pressure range from 50 to 900 mm Hg without electronic adjustments. The system should also be applicable for level detection in other liquified gases such as oxygen, hydrogen, and nitrogen.

The problem of detecting the liquid helium level in a system where the pressure can vary anywhere from 50 to 900 mm Hg required development of a level sensor operation and electronics to sense the variation of the level sensor output between liquid and cold helium gas, but which are not sensitive to the pressure variations on the liquid. In the system developed, a commercial perforated germanium cryogenic thermometer is used as the level sensor (but not as a temperature sensor) with an

adjustable level discriminator with indicators. The sensor acts as a variable resistance dependent on the power dissipated. The power dissipated varies greatly between immersion in the gas or in the liquid; hence, a large signal difference is available to discriminate between the two. Also, this sensor has the unique characteristic that, as the pressure drops, the signal when out of the liquid helium increases while the signal when in the liquid helium decreases. With the germanium sensor, it is not necessary to reset the circuit to differentiate between liquid and gas as the pressure decreases or increases, and accurate readings are obtained over a wide range of pressures. All that is necessary is that the sensor be calibrated at one atmosphere.

The amount of power required for reliable sensor

(continued overleaf)

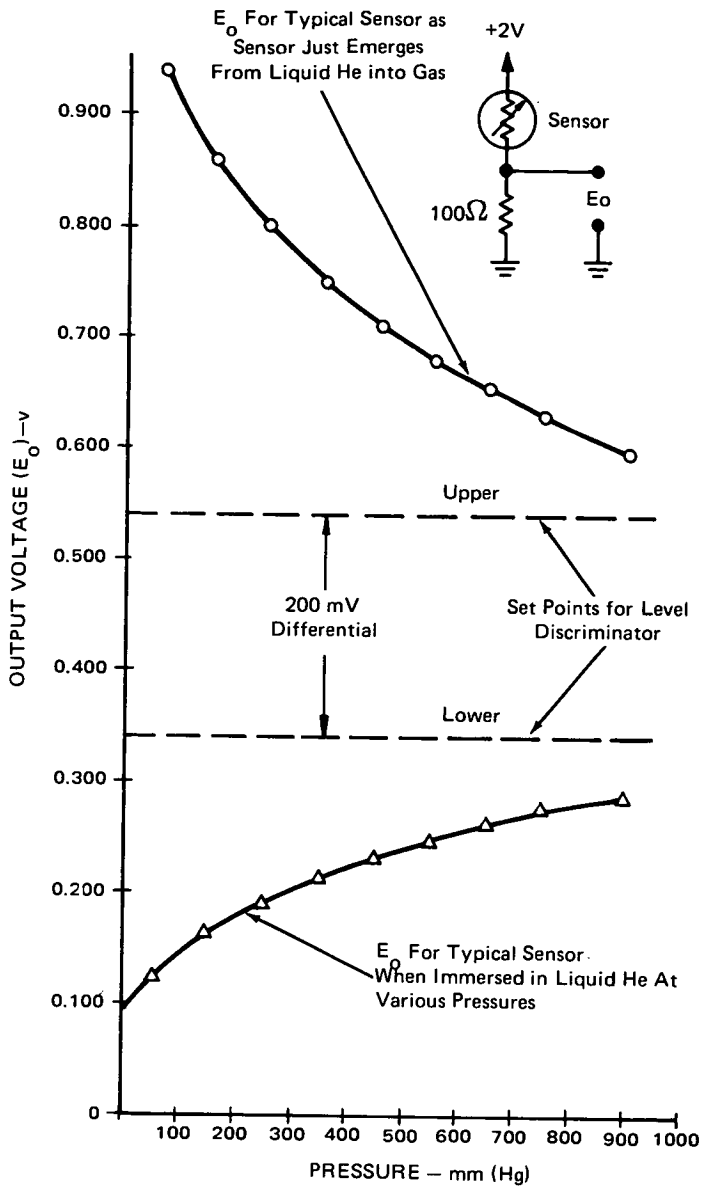

Figure 2. Operational characteristics of the level detector and indicator system.

operation over the stated pressure range was determined experimentally at a safe operating current and a minimum dissipation in the helium system. Power dissipation of the sensor in the liquid helium is approximately 4 mW at 1 atmosphere. After initial calibration, no other adjustments are necessary for repeated operation and cycling from room to liquid helium temperatures. Response time is less than 50 ms.

Figure 1 is a circuit schematic of the level detection and indicator system. The germanium sensor and the input resistor of the voltage follower form a voltage divider. When the liquid level rises above or drops below the sensor, a voltage change is sensed across the 100-ohm resistor. The voltage follower is used for isolation. The SPAN and REFERENCE pots are adjusted so that the level discriminator will trip at the set points selected from the graph in Figure 2. These points were selected to be within the voltage levels at 900 mm Hg and will remain constant for this sensor at pressures down to 50 mm Hg. The graph was plotted for a particular sensor which was cycled in and out of liquid helium at different pressures. The state of the discriminator, either high or low, determines which lamp will be lit through the lamp drivers, indicating whether the sensor is in or out of liquid helium.

**Note:**

No further documentation is available. Specific questions, however, may be directed to:

Technology Utilization Officer  
 Lewis Research Center  
 21000 Brookpark Road  
 Cleveland, Ohio 44135  
 Reference: B72-10145

**Patent Status:**

No patent action is contemplated by NASA.

Source: W.M. Krawczonek and B. Stephenson of  
 Lewis Research Center  
 (LEW-11487)