

NASA TECH BRIEF

NASA Pasadena Office



NASA Tech Briefs announce new technology derived from the U.S. space program. They are issued to encourage commercial application. Tech Briefs are available on a subscription basis from the National Technical Information Service, Springfield, Virginia 22151. Requests for individual copies or questions relating to the Tech Brief program may be directed to the Technology Utilization Office, NASA, Code KT, Washington, D.C. 20546.

Tubing Cutter

The problem:

Tools which sever tubing by means of a cutter wheel often leave a small raised lip around the cut end; the lip must be removed before the tubing can be inserted into a close-fitting hole. A manual tubing cutter was needed to cut tubing of different diameters and leave a smooth edge.

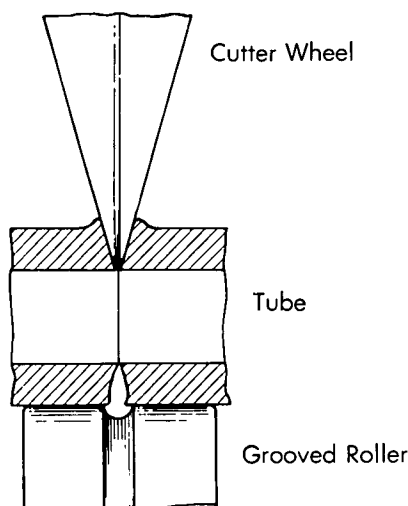

The solution:

Replace the opposing smooth rollers which are ordinarily used in tubing cutters with appropriately grooved rollers.

How it's done:

The two smooth, opposing rollers ordinarily used in tubing cutters which use a third sharp-edged,

cutting wheel are replaced with grooved rollers shaped as indicated in the lower part of the diagram.

The sharp-edged cutting wheel shown in the upper part of the diagram raises a lip on the periphery of tubing because the cutting action forces the tubing-wall material to the sides of the cut. When the cutting action begins, the small lip is cleared by the roller groove, because the groove is wider than the initial cut, but as the cut becomes wider and the lip height increases, the edges of the groove in the roller bear down on the lip and prevent it from rising. Just before the tubing is severed, the width of the cut equals the width of the roller groove (as indicated in the lower part of the diagram) and the smoothing action is complete.

Note:

Requests for further information may be directed to:

Technology Utilization Officer
 NASA Pasadena Office
 4800 Oak Grove Drive
 Pasadena, California 91103
 Reference: TSP72-10095

Patent status:

No patent action is contemplated by NASA.

Source: Anthony Giandomenico of
 Caltech/JPL
 under contract to
 NASA Pasadena Office
 (NPO-11524)

Category 07