



NATIONAL AERONAUTICS AND SPACE ADMINISTRATION
WASHINGTON, D.C. 20546

50 Lewis

REPLY TO
ATTN OF: GP

TO: USI/Scientific & Technical Information Division
Attention: Miss Winnie M. Morgan

FROM: GP/Office of Assistant General Counsel for
Patent Matters

SUBJECT: Announcement of NASA-Owned U. S. Patents in STAR

In accordance with the procedures agreed upon by Code GP and Code USI, the attached NASA-owned U. S. Patent is being forwarded for abstracting and announcement in NASA STAR.

The following information is provided:

U. S. Patent No. : 3,579,168

Government or Corporate Employee : U.S. Government

Supplementary Corporate Source (if applicable) : NA

NASA Patent Case No. : LEW-10155-1

NOTE - If this patent covers an invention made by a corporate employee of a NASA Contractor, the following is applicable:

Yes No

Pursuant to Section 305(a) of the National Aeronautics and Space Act, the name of the Administrator of NASA appears on the first page of the patent; however, the name of the actual inventor (author) appears at the heading of Column No. 1 of the Specification, following the words ". . . with respect to an invention of . . ."

Elizabeth A. Carter

Elizabeth A. Carter
Enclosure
Copy of Patent cited above

N71-29035

FACILITY FORM 602

(ACCESSION NUMBER) 5

(PAGES) 1

(NASA CR OR TMX OR AD NUMBER)

(THRU) 02

(CODE) 09

(CATEGORY)

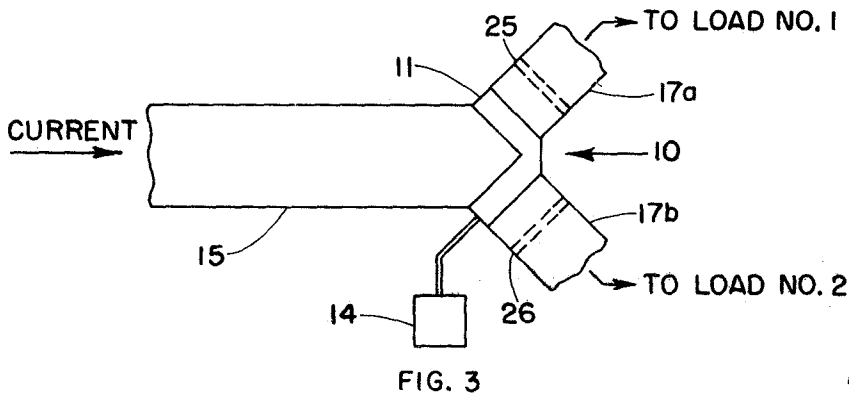
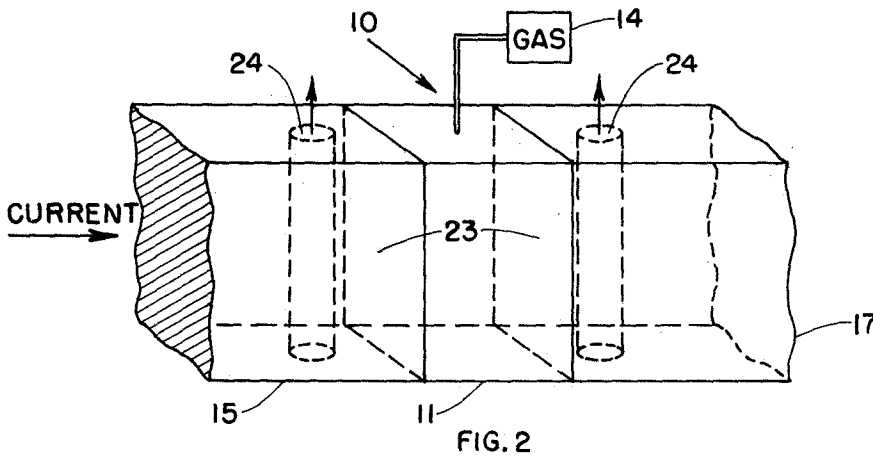
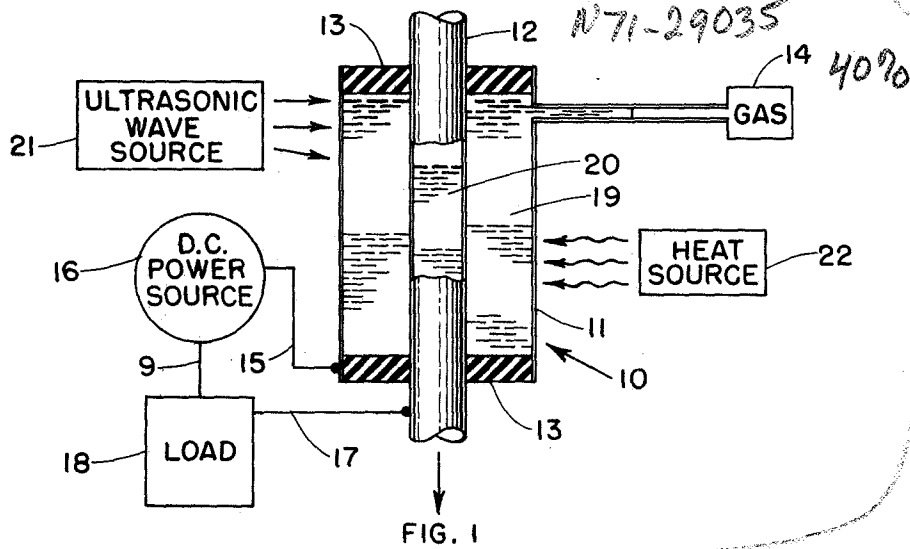

INVENTORS
ALEX VARY

BY

James Kay
Norman T. Musial
ATTORNEYS

1804

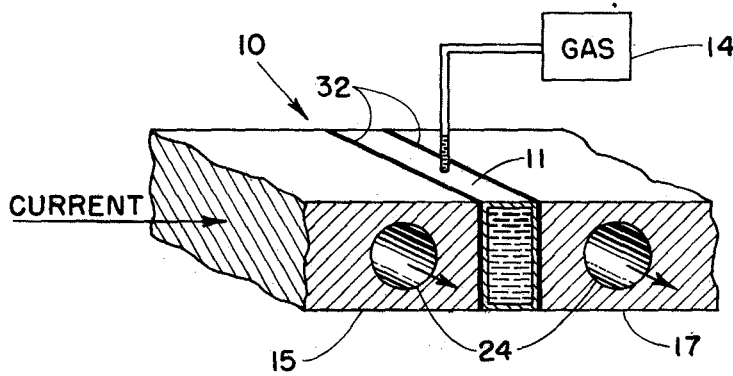

FIG. 4

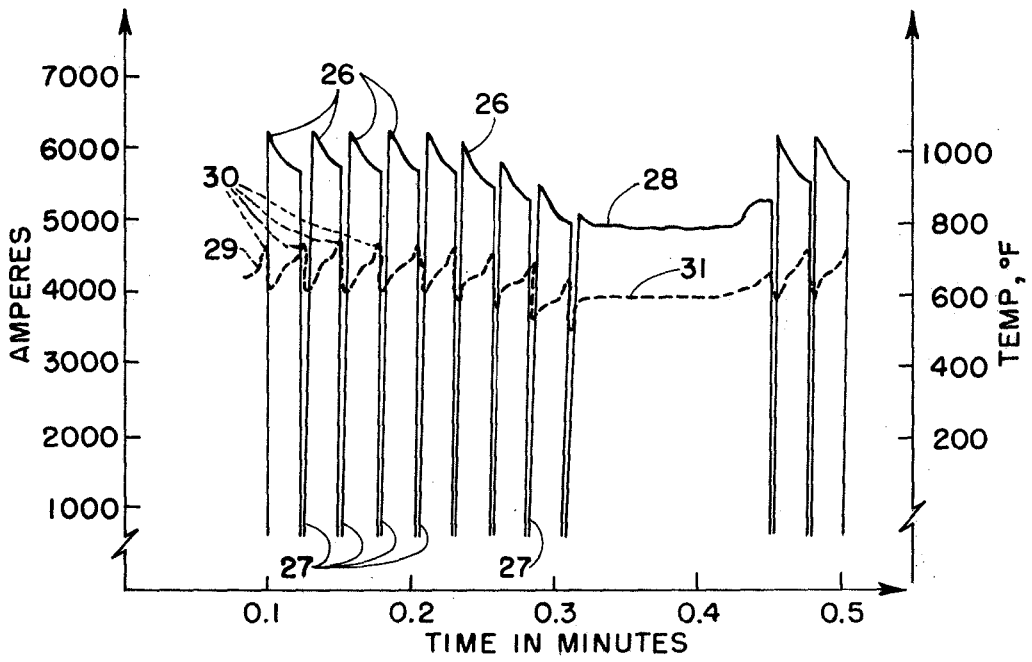

FIG. 5

INVENTORS
ALEX VARY

BY

John Coy
Norman T. Musial
ATTORNEYS

[72] Inventor **Alex Vary**
North Olmsted, Ohio
 [21] Appl. No. **889,387**
 [22] Filed **Dec. 31, 1969**
 [45] Patented **May 18, 1971**
 [73] Assignee **The United States of America as represented
 by the Administrator of the National
 Aeronautics and Space Administration**

3,176,101 3/1965 Awender et al..... 337/120X
 3,096,414 7/1963 Newman 337/121X

Primary Examiner—Bernard A. Gilheany
Assistant Examiner—Dewitt M. Morgan
Attorneys—N. T. Musial, G. E. Shook and G. T. McCoy

[54] **CYCLIC SWITCH**
 13 Claims, 5 Drawing Figs.

[52] U.S. Cl..... 337/114,
 337/121
 [51] Int. Cl..... H01h 37/36,
 H01h 87/00
 [50] Field of Search..... 337/121;
 174/9 (F); 337/114, 115, 116, 120, 121, 306

[56] **References Cited**
UNITED STATES PATENTS
 3,501,730 3/1970 Ito et al..... 337/114X

ABSTRACT: A switch utilizing a liquid metal in the cavity of a metal chamber connected in a conductor through which current flows from a DC source to a load or vice versa. Abrupt, cyclic decreases in current are effected by the formation of vapor films or vapor cavities which form at the interfaces between the liquid metal and the walls of the chamber due to ohmic heating. A source of pressurized gas communicates with the interior of the chamber. Cooling means for the chamber are provided to extract heat at a predetermined rate. The chamber may also be subjected to ultrasonic waves and heat waves to alter the wetting-dewetting action of the liquid metal.

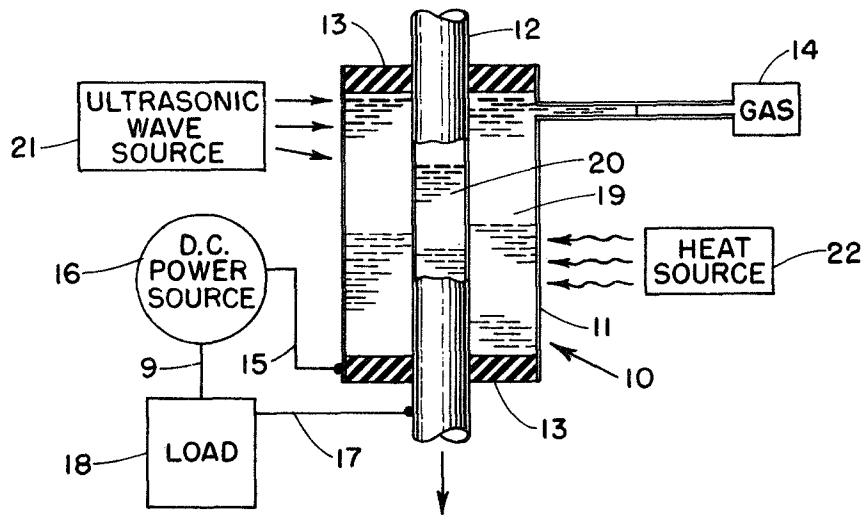

CYCLIC SWITCH

ORIGIN OF THE INVENTION

The invention described herein was made by an employee of the United States Government and may be manufactured and used by or for the Government for governmental purposes without the payment of any royalties thereon or therefor.

BACKGROUND OF THE INVENTION

This invention relates to electrical switches and is directed more particularly to a cyclic switch for high current.

In the prior art, the switching and controlling of electrical currents in the range of thousands to tens of thousands of amperes has been generally accomplished by devices such as the ignitron. The ignitron and similar devices consume large amounts of power in their operation. This is a serious disadvantage particularly in aerospace applications where efficiency is a very important consideration. Furthermore, operation of the ignitron depends on a pool of liquid mercury contained therein. Consequently, an ignitron can only be operated in substantially constant, nonzero gravity environments.

OBJECTS OF THE INVENTION

It is an object of the invention to provide an improved switch for high electrical currents.

It is another object of the invention to provide an improved switch for producing rapid, abrupt, cyclic changes in an electric current.

It is still another object of the invention to provide a cyclic switch which may be operated under 0-gravity or varying gravity conditions.

Yet another object of the invention is to provide a cyclic switch which operates at high efficiency.

Other objects and advantages of the invention will become apparent from the following description and drawings.

DESCRIPTION OF THE DRAWINGS

FIG. 1 is a cross-sectional view of a switch embodying the invention and schematically illustrates ancillary equipment which may be utilized in the invention together with the electrical circuitry into which the switch is incorporated.

FIG. 2 illustrates an embodiment of the invention wherein the switch is incorporated into a bus-bar conductor.

FIG. 3 illustrates a modification of the embodiment shown in FIG. 2 wherein the bus-bar is bifurcated to control two loads.

FIG. 4 is a longitudinal cross section showing additional details of the embodiment of FIG. 2.

FIG. 5 is a graph showing the cyclic variation of current through a switch constructed in accordance with FIG. 4 and also illustrating the variation in ohmic resistance of the switch.

DESCRIPTION OF THE PREFERRED EMBODIMENT

Referring now to FIG. 1, it will be seen that a switch embodying the invention includes a chamber 10 formed by a metal housing 11 having a metal conduit 12 extending therethrough. The conduit 12 is electrically insulated from the housing 11 by means of chamber end walls 13 which are made of an electrical insulating material. The switch embodying the invention is completed by filling the chamber 10 with a liquid metal 19 such as mercury or a liquid alkali metal such as sodium or potassium. At temperatures above 2,000° F., lithium is preferred. Although it is highly corrosive, gallium may be used. A source of pressurized gas 14 is connected to the interior of the chamber 10. Any gas which is substantially nonreactive with the liquid metal may be used. Examples of such gases include argon, xenon, neon and nitrogen.

The switch is disposed in a current carrying conductor by connecting a lead 15 between a DC power source 16 and the housing 11 and by connecting a lead 17 between the conduit 12 and a load 18. A current return path from load 18 to the DC power source 16 is provided by a lead 9 connected

between the power source 16 and the load 18. It will be understood that the load 18 may be the primary winding of a transformer having a utilization device connected across its secondary winding.

To the end that heat will be extracted from the mercury in the chamber 10 at a predetermined rate so that mercury wetting and dewetting action occurs in a manner to provide a predetermined cyclic interruption or variation of current flowing from the DC power source 16 to the load 18, a cooling medium 20 is disposed in the conduit 12. The cooling medium 20 may be either flowing or stationary, or it may be solid or liquid.

To give more precise control of the cyclic operation of the switch, external energy sources may be advantageously used. For example, to increase the speed and effectiveness of the dewetting action of the mercury 19 in the chamber 10, ultrasonic waves from an ultrasonic generator 21 may be impressed on the chamber 10. In a like manner, to increase the speed of ohmic heating in the switch heat may be applied to the chamber 10 from a heat source 22. If desired, both the ultrasonic wave source 21 and the heat source 22 may be operated in a pulsing mode of predetermined frequency compatible to the desired interruption frequency of the switch.

Operation of the embodiment shown in FIG. 1 will now be described. Assuming that the lead 15 is connected to the positive side of the DC power source 16, current will flow from the power source through the lead 15, the housing 11, the liquid metal 19, the conduit 12, and the lead 17 to the load 18. The current will return to the power source by way of lead 9. Because of the characteristic of liquid metals whereby they do not establish a good electrical connection with certain metals which they contact, there is a substantial amount of electrical resistance at the interface between the liquid metal and the housing 11 and the interface between the liquid metal and the conduit 12. Consequently, heat is generated at these interfacial areas. This heating induces wetting of the surfaces of the housing 11 and the conduit 12 thereby reducing the interfacial resistances. However, heat continues to be generated by the current and, consequently, the temperature of the liquid metal 19 continues to rise. After the temperature reaches a specific value dependent on what liquid metal is being used, a vapor film or disconnected vapor cavity forms between the liquid metal 19 and each of the surfaces of the housing 11 and the conduit 12. This dewetting action causes loss of electrical contact and, therefore, the current being supplied from the power source 16 to the load 18 drops to a very low value.

Heat is now being extracted from the liquid metal 19 faster than it is being generated by the interfacial resistances. As a result the vapor films at the interfaces collapse. This allows the liquid metal 19 to again make good contact with the housing 11 and the conduit 20 to reestablish maximum current flow from the power source 16 to the load 18.

The foregoing wetting-dewetting action will be repetitive so long as heat is not extracted from the liquid metal 19 faster than the temperature can be increased to cause vapor formation at the interfaces. Of course the pressure of the gas source 14 will be a factor influencing the repetition frequency and must be adjusted accordingly.

To speed up the dewetting action of the switch, ultrasonic waves may be directed against the housing 11 by an ultrasonic wave source 21. The dewetting action may also be aided by subjecting the housing 11 to heat from a heat source 22. Thus, the cyclic frequency of current variation may be altered in a desired manner by applying heat or ultrasonic waves and by controlling the rate of heat extracted as well as by adjusting the pressure of the gas source 14.

ALTERNATE EMBODIMENTS OF THE INVENTION

FIG. 2 illustrates an embodiment of the invention suited for use with heavy bus-bar conductors. Parts in FIG. 2 corresponding to those in FIG. 1 are identified by like numerals. As shown in FIG. 2 the chamber 10 comprises a housing 11

having flat rectangular end walls 23 which contact the bus-bar conductors 15 and 17. Heat is extracted from the chamber 10 by means of cooling passages 24 which contain a cooling medium.

In the embodiment of FIG. 3, the chamber 10 is formed in a V-shape and is positioned against a wedge-shaped end of a conductor bus-bar 15. Conductors 17a and 17b extend from respective outside surfaces of the V-shaped chamber, conductor 17a being connected to a first load (not shown) while conductor 17b is connected to a second load (not shown). Heat extracted for the chamber 10 is provided for by a coolant passage 25 in the conductor 17a and a coolant passage 26 in the conductor 17b. Operation of the switch formed by the foregoing structure is similar to that of the switch shown in FIG. 1.

The embodiment of the invention shown in FIG. 4 is a longitudinal cross section showing additional details of the embodiment shown in FIG. 2 and like parts are identified by like numerals. In FIG. 4, the chamber 10 is formed by a housing of cobalt alloy, HS-25 (L-605). The bus-bar 15 and 17 are of copper and are brazed to the housing 11 using a 45 percent silver braze 32. A source of pressurized gas 14 communicates with the interior of the chamber 10 which contains liquid mercury.

The variation in temperature and in current of the switch are illustrated in the graph shown in FIG. 5. The dashed line 29 indicates the cyclic temperature variation with the maximum values being indicated by numeral 30.

The current maximums are identified by numerals 26 in FIG. 5, while the cyclic current drops or decreases are indicated at 27. Each time the temperature reaches a maximum 30, cavitation occurs between the liquid mercury and the chamber walls. This causes an immediate abrupt decrease in current and, consequently, temperature also decreases. When the temperature again reaches a maximum 26, current will again decrease abruptly.

When the temperature is prevented from increasing above a certain magnitude 31, cavitation does not occur, thereby causing a constant, uninterrupted current as at 28. Thus it will be seen that heat extraction must be adjusted such that the repetitive interruption of current will occur.

The values of time, temperature and amperes indicated in FIG. 5 are for the specific embodiment of FIG. 4. However, the solid and dashed lines representing current and temperature, respectively, are also representative of the temperature and current variation of the embodiment shown in FIG. 1.

It will be understood that the above-described cyclic switch may be changed or modified without departing from the spirit and scope of the invention as set forth in the claims appended hereto.

I claim:

1. A switch for cyclically varying current being supplied from a DC source to a load comprising:
a conductor connected between said DC source and said

load;

a metal chamber disposed in said conductor in electrical contact therewith;
a liquid metal disposed in said chamber, said liquid metal substantially filling said chamber;
a source of pressurized gas communicating with said chamber; and
means for cooling said liquid metal.

2. The switch of claim 1 and further including means for impressing ultrasonic waves on said chamber.

3. The switch of claim 1 and further including means for heating said chamber and said liquid metal contained therein.

4. The switch of claim 1 wherein said liquid metal is selected from the group consisting of mercury, sodium, potassium and lithium.

5. The switch of claim 1 wherein said chamber has at least two oppositely facing flat sides contacting respective end faces of a bus-bar.

6. The switch of claim 5 wherein said cooling means comprises passageways formed in said bus-bar adjacent to at least one of said flat sides of said chamber, a cooling medium being disposed in said passageways.

7. The switch of claim 5 wherein said flat sides of said chamber are silver brazed to said respective end faces of said bus-bar.

8. The switch of claim 1 wherein said conductor is a bifurcated bus-bar and said chamber is V-shaped having a pair of upper surfaces contacting respective faces of a wedge-shaped bus-bar, each of the bifurcations contacting a respective lower surface of said V-shaped chamber.

9. The switch of claim 8 wherein said cooling means comprise a passageway formed in each bifurcation adjacent to said lower surfaces of said chamber, each passageway containing a cooling medium.

10. A switch for interrupting current flowing from a DC source to a load comprising:

a metal housing;

a metal conduit extending through said housing,

electrical conductor means connecting said DC source, said load, said housing and said conduit;

a heat-absorbing medium disposed in said conduit;

electrical insulating means disposed between said housing and said conduit;

a liquid metal substantially filling said housing; and

a source of pressurized gas communicating with said housing, said DC source and said load being serially connected between said housing and said conduit.

11. The switch of claim 10 and further including means for impressing ultrasonic waves on said housing.

12. The switch of claim 10 and further including means for heating said housing and said liquid metal contained therein.

13. The switch of claim 10 wherein said gas is selected from the group consisting of xenon, argon, neon and nitrogen.

55

60

65

70

75