



NATIONAL AERONAUTICS AND SPACE ADMINISTRATION
WASHINGTON, D.C. 20546

Dangley

REPLY TO
ATTN OF: GP

TO: USI/Scientific & Technical Information Division
Attention: Miss Winnie M. Morgan

FROM: GP/Office of Assistant General Counsel for
Patent Matters

SUBJECT: Announcement of NASA-Owned U. S. Patents in STAR

In accordance with the procedures agreed upon by Code GP and Code USI, the attached NASA-owned U. S. Patent is being forwarded for abstracting and announcement in NASA STAR.

The following information is provided:

U. S. Patent No. : 3,579,242

Government or Corporate Employee : U.S. Government

Supplementary Corporate Source (if applicable) : NA

NASA Patent Case No. : KLA-10772

NOTE - If this patent covers an invention made by a corporate employee of a NASA Contractor, the following is applicable:

Yes No

Pursuant to Section 305(a) of the National Aeronautics and Space Act, the name of the Administrator of NASA appears on the first page of the patent; however, the name of the actual inventor (author) appears at the heading of Column No. 1 of the Specification, following the words ". . . with respect to an invention of . . ."

Elizabeth A. Carter

Elizabeth A. Carter
Enclosure
Copy of Patent cited above

FACILITY FORM 602

N71-28980

(ACCESSION NUMBER)

3
(PAGES)

(NASA CR OR TMX OR AD NUMBER)

(THRU)

00
(CODE)

07
(CATEGORY)

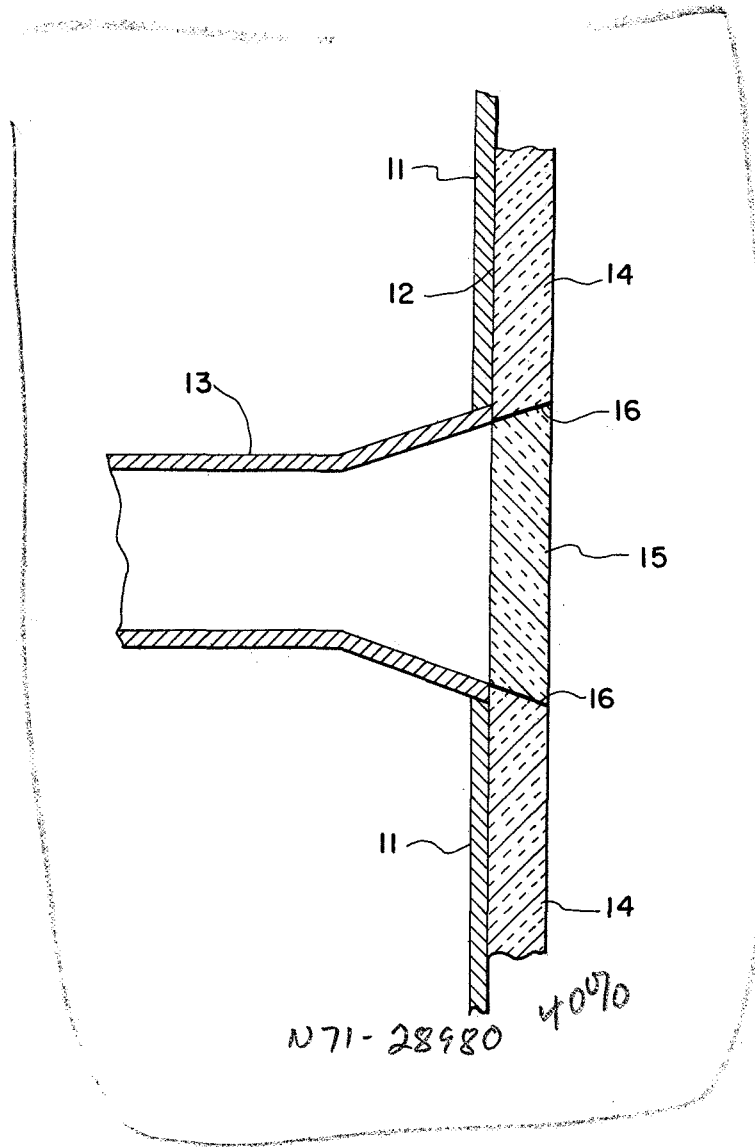

INVENTOR.
WILLIAM L. GRANTHAM

BY *A. J. King & Co.*
William H. King
ATTORNEYS

1794

[72] Inventor **William L. Grantham**
 Yorktown, Va.
 [21] Appl. No. **887,700**
 [22] Filed **Dec. 23, 1969**
 [45] Patented **May 18, 1971**
 [73] Assignee **the United States of America as represented
 by the Administrator of the National
 Aeronautics and Space Administration**

[56] **References Cited**
 UNITED STATES PATENTS
 3,346,865 10/1967 Jones..... 343/708
 3,384,895 5/1968 Webb..... 343/708
Primary Examiner—Eli Lieberman
Attorneys—William H. King, Howard J. Osborn and G. T.
 McCoy

[54] **ANTENNA DESIGN FOR SURFACE WAVE
 SUPPRESSION**
 6 Claims, 1 Drawing Fig.
 [52] U.S. Cl..... **343/708,**
 343/784, 343/872
 [51] Int. Cl..... **H01q 1/28,**
 H01q 13/00
 [50] Field of Search..... 343/705,
 708, 784, 785, 783, 786, 872

ABSTRACT: Means for suppressing the excitation of electromagnetic surface waves on a dielectric converter antenna. A hole is cut in the dielectric where it covers the antenna. A plug of the dielectric material is coated around its rim with a metal and then fitted into the hole such that the metal coating extends the conducting surface of the antenna through the dielectric material. The metallic coating minimizes the possibility of surface wave excitation by confining the waves reflected by the dielectric-air interface to the chamber formed by the coating.

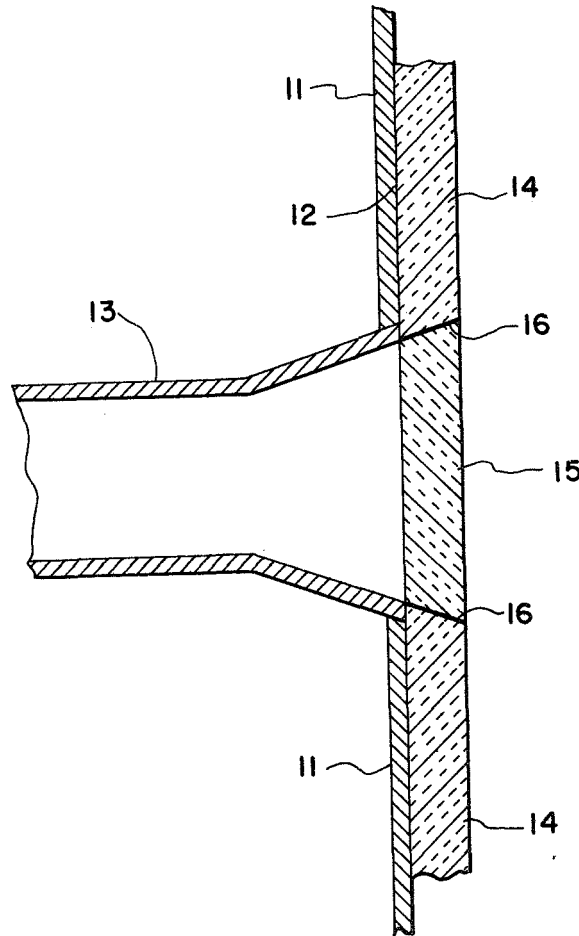

ANTENNA DESIGN FOR SURFACE WAVE SUPPRESSION**ORIGIN OF THE DISCLOSURE**

The invention described herein was made by an employee of the United States Government and may be manufactured and used by or for the Government for governmental purposes without the payment of any royalties thereon or therefore.

BACKGROUND OF THE INVENTION

The invention relates generally to antennas and more specifically concerns a spacecraft antenna design for surface wave suppression.

A spacecraft's outside surface is usually covered with a layer of dielectric material for heat protection to the spacecraft. During hypervelocity entry of the spacecraft into the earth's atmosphere the layer of dielectric material ablates thereby keeping the temperature of the spacecraft below a critical value. Each existing antenna which must be covered by this layer of dielectric material, permits the excitation of electromagnetic surface waves which seriously degrade the antenna's pattern and the antenna's usefulness as a plasma diagnostic sensor. It is therefore the primary purpose of this invention to provide means for suppressing the excitation of electromagnetic surface waves on dielectric covered antennas.

SUMMARY OF THE INVENTION

The invention is applicable to horn, T-fed slot and similarly constructed antennas. It consists of a thin metallic walled extension of the antenna's conducting surfaces through the layer of dielectric material that covers the spacecraft. The use of the metallic walled extension minimizes the possibility of surface wave excitation by confining the waves reflected by the dielectric-air interface to a chamber formed by the metallic walls. The reflected waves would normally contribute appreciable to the generation of surface waves and thus to the degradation of antenna performance. The thin metallic wall, about 1 to 10 microns thick, is deposited by some suitable technique, such as vapor depositing, on a dielectric plug the same size as the antenna aperture and inserted in a hole provided for it at the aperture of the antenna. The main feature of the device that constitutes this invention is its ability to provide the electrical improvement desired and, by the use of thin walls, not impair the ablative character of the dielectric material. The thin metallic walls recess with the dielectric as ablation occurs so that surface protrusions and recessions which would seriously affect the dielectric's heat protection capability are avoided.

BRIEF DESCRIPTION OF THE DRAWING

The sole FIGURE in the drawing is a schematic diagram of the invention.

DETAILED DESCRIPTION OF THE INVENTION

Turning now to the embodiment of the invention selected for illustration in the drawing the number 11 designates a cross section of the outside structure of a spacecraft having an outside surface 12. A horn antenna 13 is mounted inside the spacecraft such that it extends through outside structure 11 and is flush with outside surface 12. Even though a horn antenna is disclosed it is to be understood that the invention is also applicable to T-fed slot and similarly constructed antennas. Outside surface 12 and the aperture of antenna 13 are covered with a layer of dielectric material 14. The purpose of this layer of dielectric material is to provide heat protection for the spacecraft as it enters the earth's atmosphere at a hypervelocity. As the spacecraft enters the earth's atmosphere

the dielectric material 14 ablates thereby maintaining the temperature of the spacecraft below a critical value. Ordinarily electromagnetic waves emitted from antenna 14 are partially reflected by the dielectric-air interface at the forward surface of layer 14. These reflected waves contribute appreciably to the generation of surface waves in the dielectric and thus to the degradation of antenna performance.

The present invention consists of cutting a hole in layer 14 over the aperture of antenna 13 that is slightly larger than the aperture of the antenna. A plug 15 of the dielectric material is coated on its rim by a metal to form a thin layer 16 of the metal all along the rim. The metal can be the same metal as in antenna 13 or any electrically conducting metal. The metal layer 16 is formed on the rim of plug 15 by any suitable technique such as vapor deposition and is about 1 to .10 microns thick. Plug 15 with layer 16 is fitted into the hole in the layer 14 of dielectric material so that metallic layer 16 makes contact with antenna 13 around the periphery of the aperture of the antenna. The use of the metallic wall formed by layer 16 minimizes the possibility of surface wave excitation by confining the waves reflected by the dielectric-air interface to a chamber formed by the metallic wall.

The advantages of this invention are its ability to provide the electrical improvement required and not impair the ablative character of the dielectric material. The thin metallic layer 16 recesses with the dielectric material 14 as ablation occurs so that surface protrusions and recessions are avoided which would seriously affect the dielectric's heat protection capability.

What is claimed as new and desired to be secured by Letter Patent of the United States is:

I claim:

1. Apparatus comprising:

an antenna mounted on a spacecraft such that the antenna is flush with the outside surface of the spacecraft;
a heat protection layer of dielectric material extending over the outside surface of the spacecraft and covering said antenna;
a thin metallic walled extension of said antenna's conducting surface through said layer of dielectric material whereby electromagnetic surface waves are suppressed by the metallic wall and the metallic wall does not impair the ablative character of the dielectric material.

2. Apparatus according to claim 1 wherein said thin metallic wall comprises a dielectric plug the same size as the antenna aperture coated with a thin metallic wall and inserted into the hole provided for it at the antenna.

3. Apparatus according to claim 2 wherein said antenna is a horn antenna.

4. Apparatus according to claim 2 wherein said coating is about 1 to 10 microns thick.

5. Method of making apparatus for suppressing the excitation of electromagnetic surface waves on an antenna covered by a layer of dielectric material comprising the steps of:

cutting a hole in said layer of dielectric material over the aperture of said antenna;
cutting a plug of said material slightly smaller than said hole;
coating the rim of said plug with a thin layer of metal so that the coated plug is the same size as the hole; and
fitting said coated plug into said hole so that said layer of metal makes contact with said antenna.

6. Apparatus for suppressing the excitation of electromagnetic surface waves on an antenna covered by a layer of dielectric material comprising:

a hole in said layer of dielectric material over the aperture of said antenna; and
a plug of said dielectric material, coated on its rim with a thin layer of metal, fitted into said hole such that said layer of metal makes contact with said antenna.