



NATIONAL AERONAUTICS AND SPACE ADMINISTRATION  
WASHINGTON, D.C. 20546

*11/11/69*

REPLY TO  
ATTN OF: GP

TO: USI/Scientific & Technical Information Division  
Attention: Miss Winnie M. Morgan

FROM: GP/Office of Assistant General Counsel for  
Patent Matters

SUBJECT: Announcement of NASA-Owned U. S. Patents in STAR

In accordance with the procedures agreed upon by Code GP and Code USI, the attached NASA-owned U. S. Patent is being forwarded for abstracting and announcement in NASA STAR.

The following information is provided:

U. S. Patent No. : 3,564,564

Government or Corporate Employee : North America Rockwell Corp  
Downey, Calif.

Supplementary Corporate Source (if applicable) : \_\_\_\_\_

NASA Patent Case No. : MSC-15474-1

NOTE - If this patent covers an invention made by a corporate employee of a NASA Contractor, the following is applicable:

Yes  No

Pursuant to Section 305(a) of the National Aeronautics and Space Act, the name of the Administrator of NASA appears on the first page of the patent; however, the name of the actual inventor (author) appears at the heading of Column No. 1 of the Specification, following the words ". . . with respect to an invention of . . ."

*Elizabeth A. Carter*

Elizabeth A. Carter  
Enclosure  
Copy of Patent cited above

FACILITY FORM 602

**N71-26162**  
(ACCESSION NUMBER)

14  
(PAGES)

(NASA CR OR TMX OR AD NUMBER)

(THRU)

00  
(CODE)

15  
(CATEGORY)

N71-26162

Feb. 16, 1971

T. O. PAINE  
ADMINISTRATOR OF THE NATIONAL AERONAUTICS  
AND SPACE ADMINISTRATION  
LATCHING MECHANISM

3,564,564

Filed Nov. 21, 1969

8 Sheets-Sheet 1

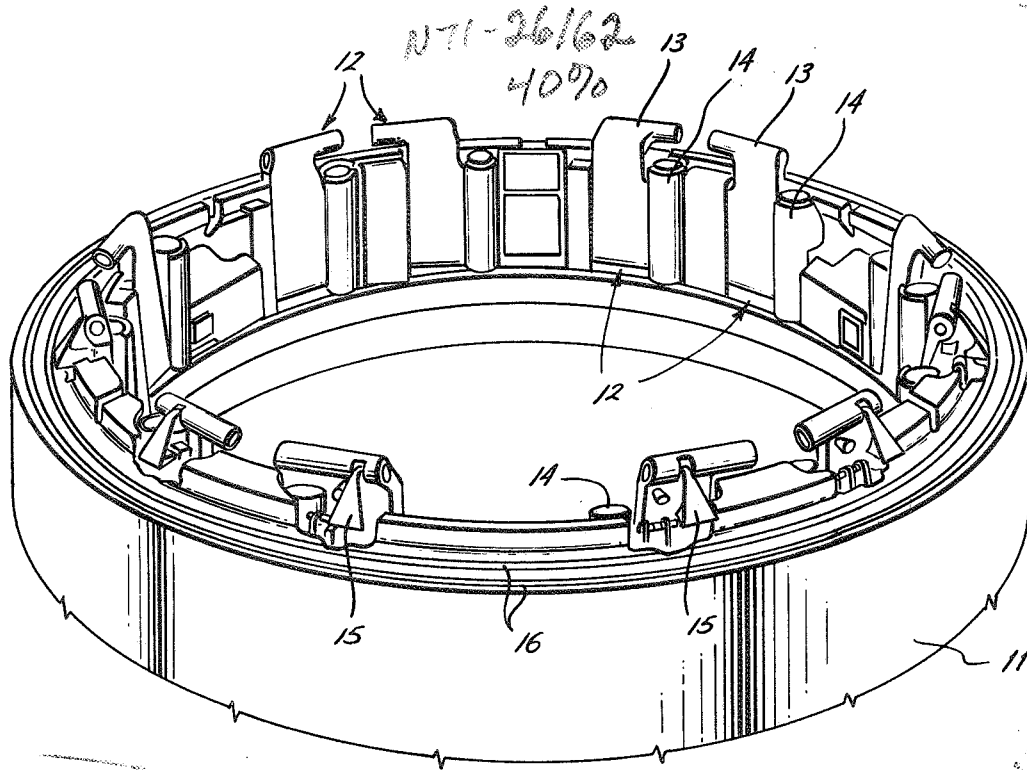

*Fig. 1*

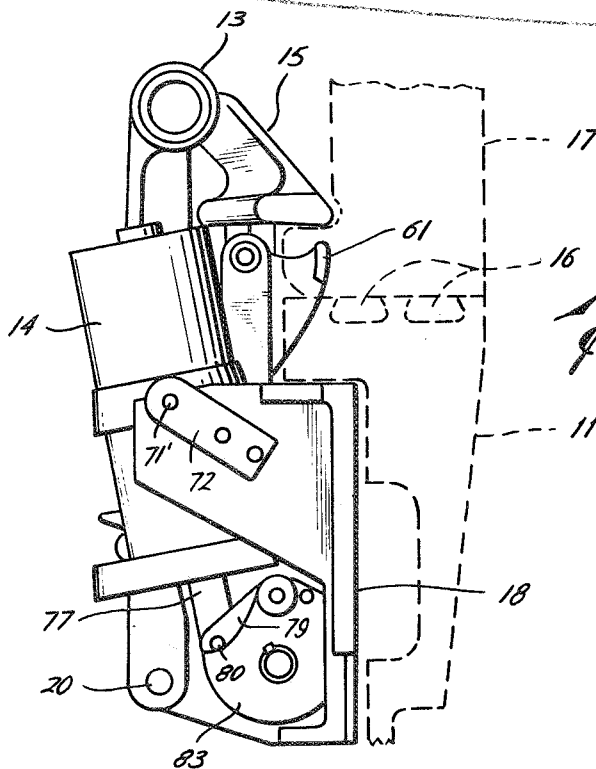

*Fig. 2*

Jacob C. Cobin  
Leo L. Rhodes  
INVENTORS

BY *John S. Coy*  
Russell E. Schlauff  
ATTORNEYS

1601

Feb. 16, 1971

T. O. PAINE  
ADMINISTRATOR OF THE NATIONAL AERONAUTICS  
AND SPACE ADMINISTRATION  
LATCHING MECHANISM

3,564,564

Filed Nov. 21, 1969

8 Sheets-Sheet 2

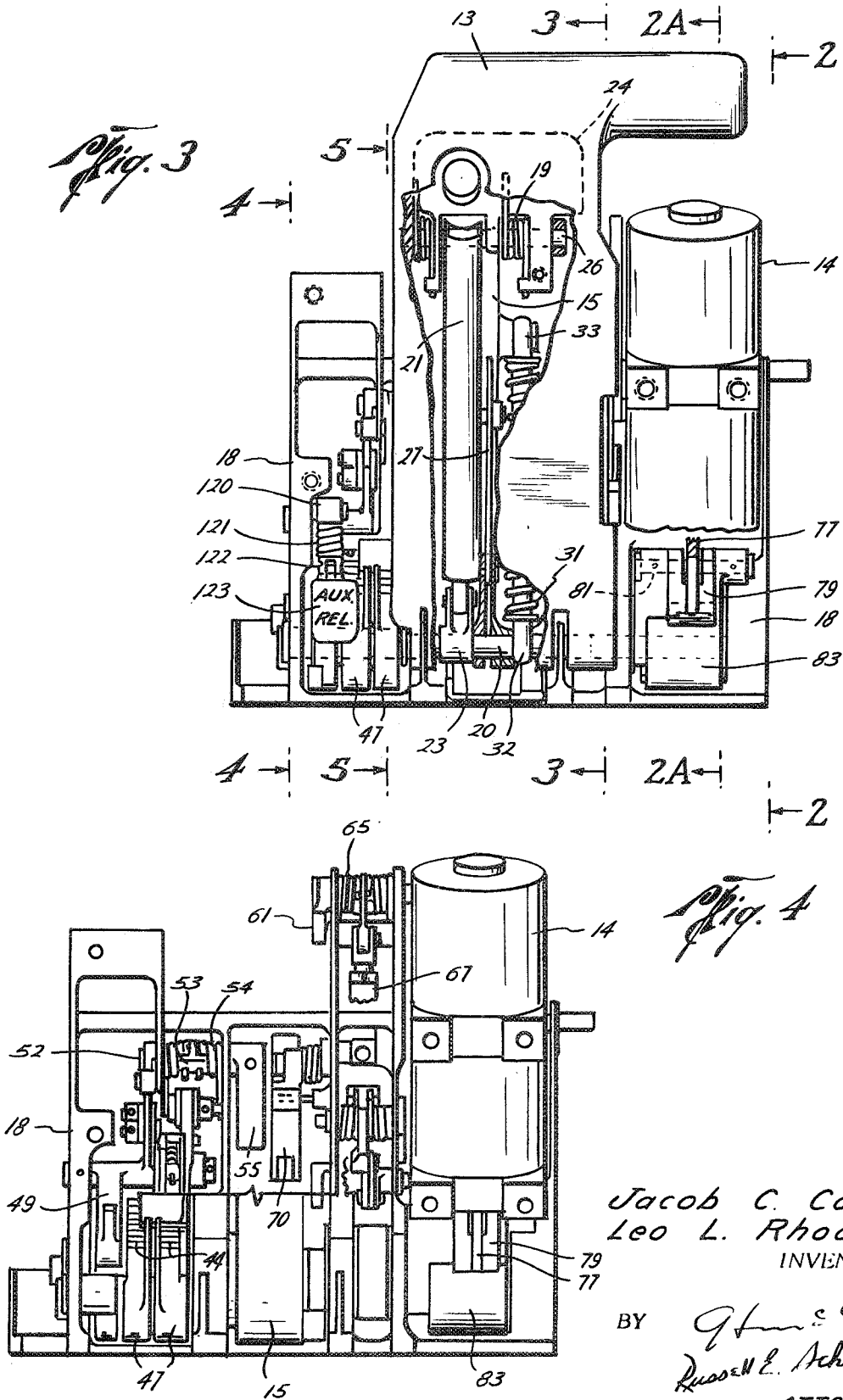

Jacob C. Cobin  
Leo L. Rhodes  
INVENTORS

BY *Robert E. Schloff*  
ATTORNEYS

Feb. 16, 1971

T. O. PAINE  
ADMINISTRATOR OF THE NATIONAL AERONAUTICS  
AND SPACE ADMINISTRATION  
LATCHING MECHANISM

3,564,564

Filed Nov. 21, 1969

8 Sheets-Sheet 5

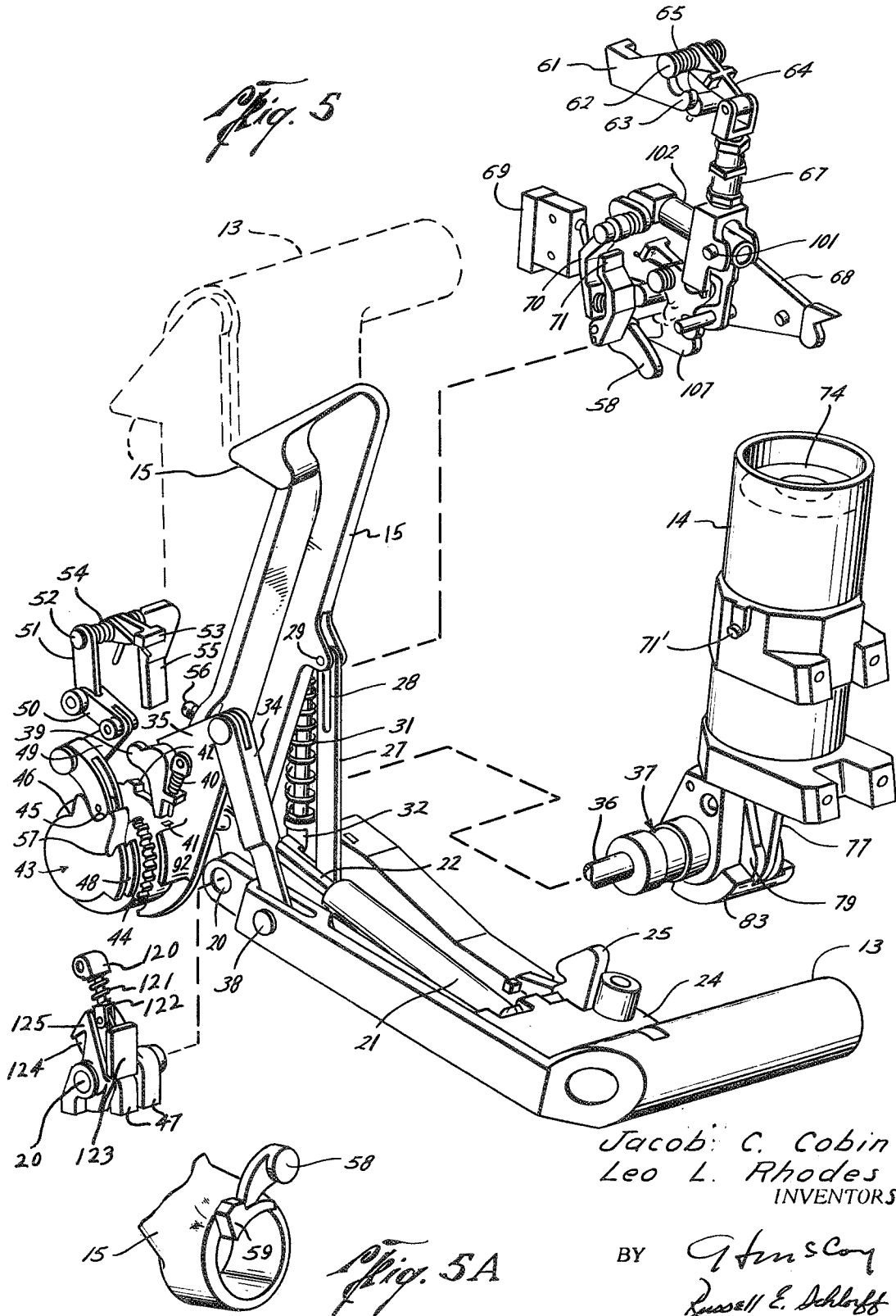

Jacob C. Cobin  
Leo L. Rhodes  
INVENTORS

BY *Ginscoy*  
Russell E. Schloft  
ATTORNEYS

Feb. 16, 1971

T. O. PAINE  
ADMINISTRATOR OF THE NATIONAL AERONAUTICS  
AND SPACE ADMINISTRATION  
LATCHING MECHANISM

3,564,564

Filed Nov. 21, 1969

8 Sheets-Sheet 4

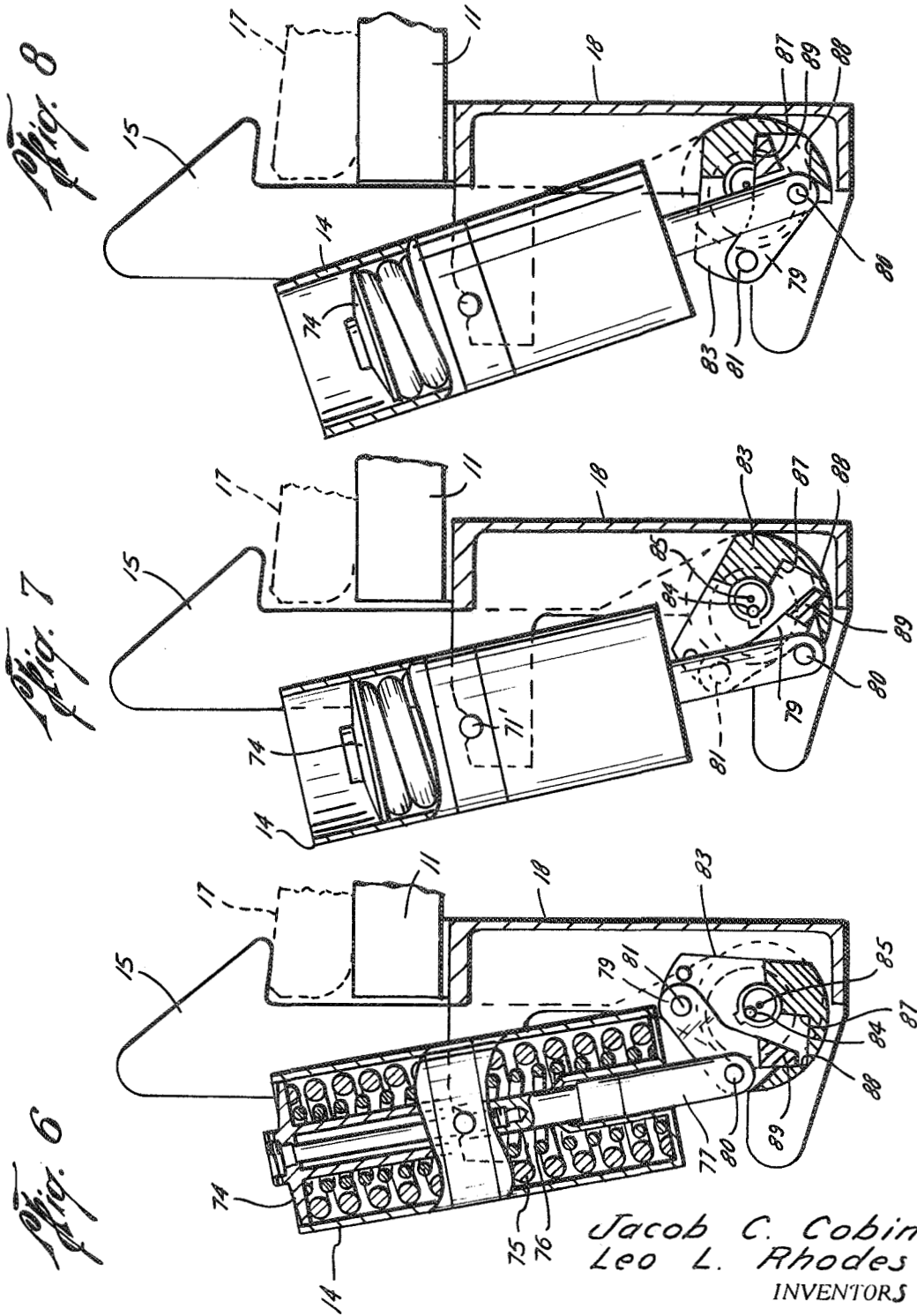

BY *Russell E. Schloff*  
Russell E. Schloff  
ATTORNEYS

Feb. 16, 1971

T. O. PAINE  
ADMINISTRATOR OF THE NATIONAL AERONAUTICS  
AND SPACE ADMINISTRATION  
LATCHING MECHANISM

3,564,564

Filed Nov. 21, 1969

8 Sheets-Sheet 8

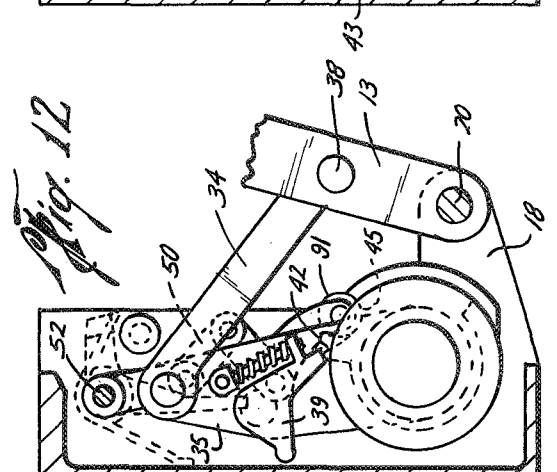
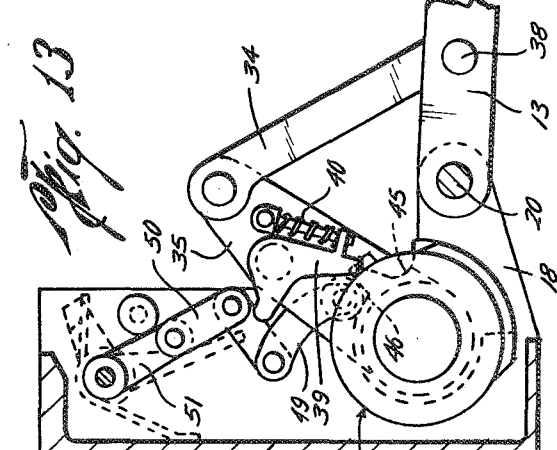
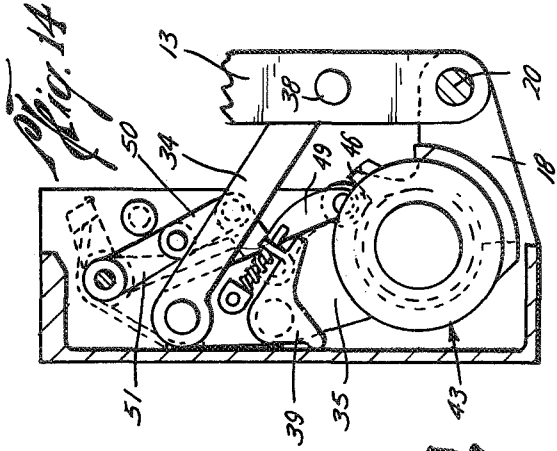
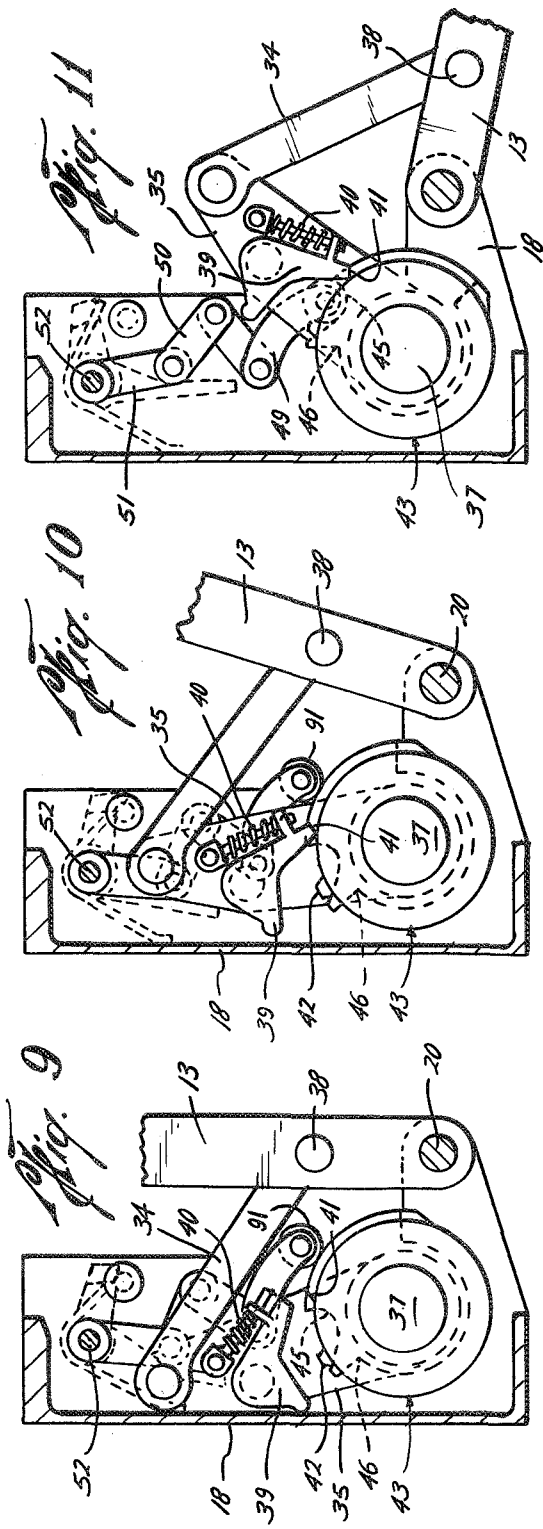

Jacob C. Cobin  
Leo L. Rhodes  
INVENTORS

BY *Glancy*  
Russell E. Schreff  
ATTORNEYS

Feb. 16, 1971

T. O. PAINE  
ADMINISTRATOR OF THE NATIONAL AERONAUTICS  
AND SPACE ADMINISTRATION  
LATCHING MECHANISM

3,564,564

Filed Nov. 21, 1969

8 Sheets-Sheet 6

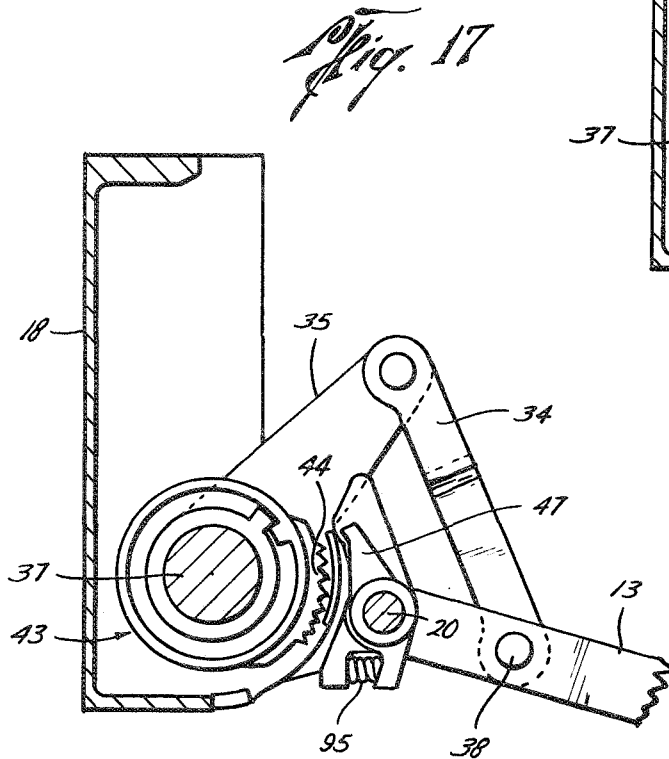
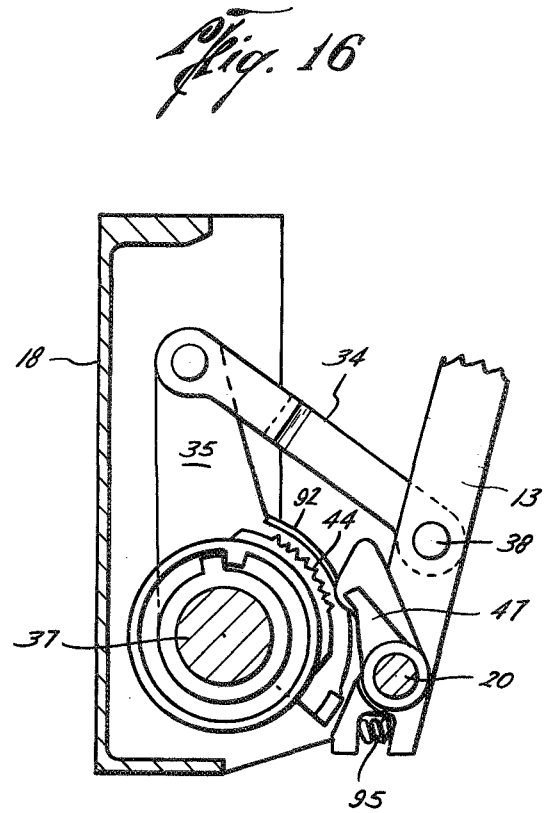
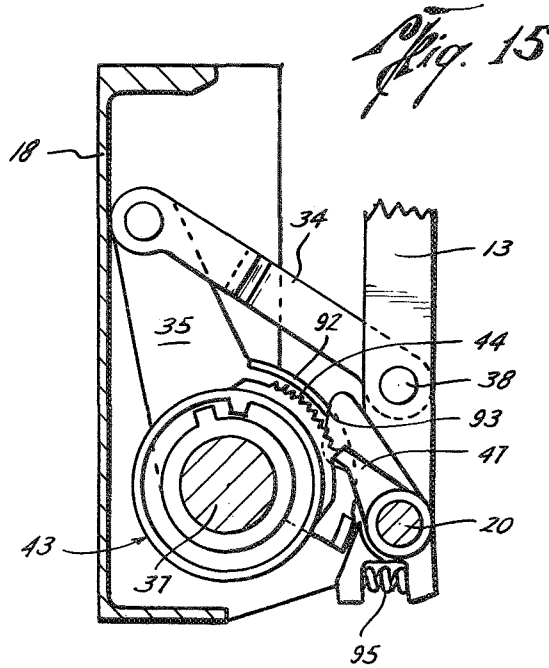

Jacob C. Cobin  
Leo L. Rhodes  
INVENTORS

BY *Russell E. Schlorff*  
Russell E. Schlorff  
ATTORNEYS

Feb. 16, 1971

T. O. PAINE  
ADMINISTRATOR OF THE NATIONAL AERONAUTICS  
AND SPACE ADMINISTRATION  
LATCHING MECHANISM

3,564,564

Filed Nov. 21, 1969

8 Sheets-Sheet 7

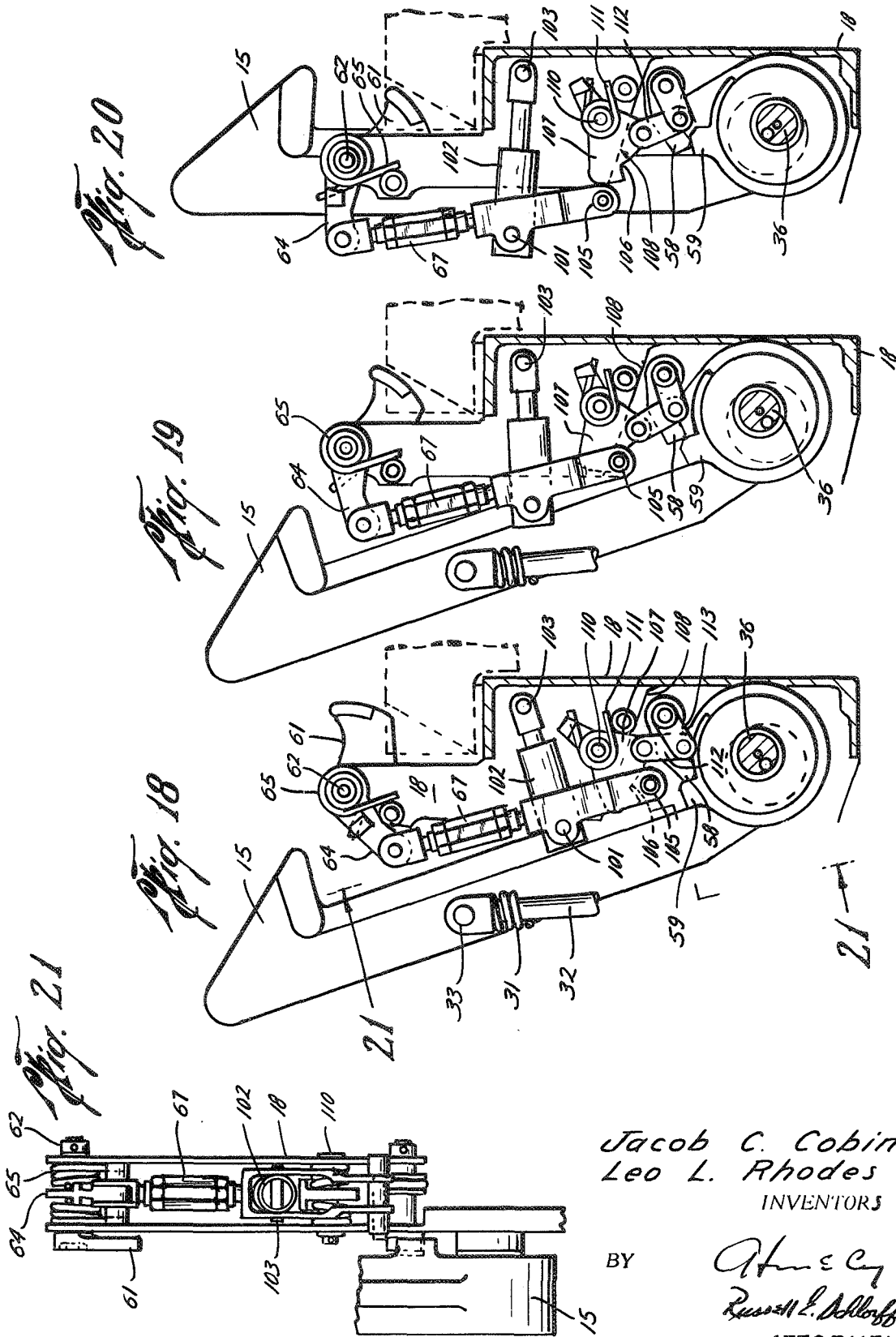

Jacob C. Cobin  
Leo L. Rhodes  
INVENTORS

BY

*Attorneys*  
Russell E. DeLoeff  
ATTORNEYS



Feb. 16, 1971

T. O. PAINE  
ADMINISTRATOR OF THE NATIONAL AERONAUTICS  
AND SPACE ADMINISTRATION  
LATCHING MECHANISM

3,564,564

Filed Nov. 21, 1969

8 Sheets-Sheet 8

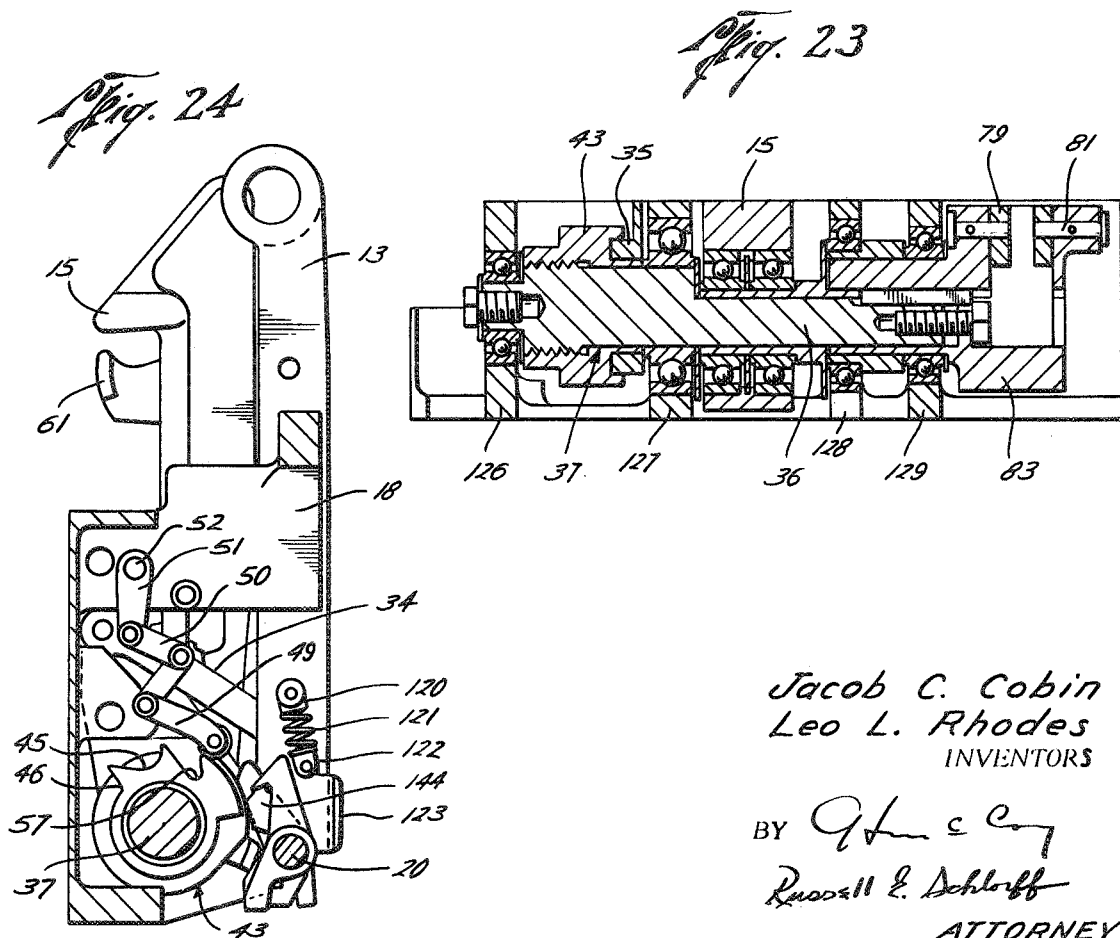
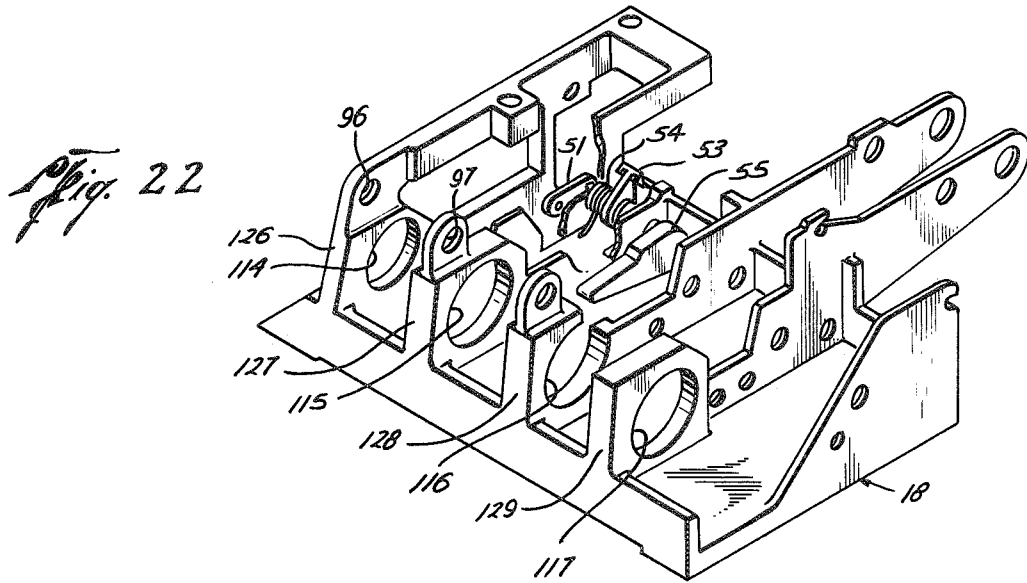

Jacob C. Cobin  
Leo L. Rhodes  
INVENTORS

BY *Russell E. Schloff*  
Russell E. Schloff  
ATTORNEYS

1

3,564,564

**LATCHING MECHANISM**

T. O. Paine, Administrator of the National Aeronautics and Space Administration with respect to an invention of Jacob C. Cobin, Los Angeles, and Leo L. Rhodes, Palos Verdes Estates, Calif.

Filed Nov. 21, 1969, Ser. No. 878,731

Int. Cl. A44b 21/00

U.S. Cl. 24—263

17 Claims

**ABSTRACT OF THE DISCLOSURE**

A latch for latching docking rings on a space vehicle, for example. It includes a latching hook connected to a stored energy power package, such as a spring, and a cocking handle which simultaneously unlatches the hook and stores energy in the power package. It also includes triggering means to properly position the hook and to retain the hook in the cocked position until released at the desired time.

**ORIGIN OF THE INVENTION**

The invention described herein was made in the performance of work under an NASA contract and is subject to the provisions of Section 305 of the National Aeronautics and Space Act of 1958, Public Law 85-568 (72 Stat. 435; 42 U.S.C. 2457).

**BACKGROUND OF THE INVENTION**

**Field of the invention**

This invention relates to a novel latch. More particularly, it relates to an automatic latch for securely clamping together two objects.

**Description of the prior art**

Prior art latches used in connection with the latching together of docking rings of the command module and the lunar module of the Apollo spacecraft in the space environment provided only semi-automatic latching, which latches required subsequent manual operation to obtain the required hook preload on the lunar module docking ring, for example. Also, the prior art latches did not provide adequate hook travel to allow for lunar module ring distortion. U.S. Pat. No. 3,346,929 is generally illustrative of the prior art over which the present invention is an improvement.

**SUMMARY OF THE INVENTION**

It is therefore an object of this invention to provide an improved latch which provides full automatic actuation and preloading at the initial docking with sufficient hook travel to allow for lunar module ring distortion and adverse tolerance accumulation.

It is also an object of this invention to provide a latch having multiple stage cocking and automatic drive pawl disconnect means, with the mechanical arrangement such that there is provided means for locking in stored energy in a power device with more than one cocking stroke of an operating handle to reduce the operating force and to additionally automatically disconnect the driving pawl from the ratchet to remove interference during power release actuation.

It is also an object of this invention to provide automatic no-back ratchet disconnect means wherein the mechanical arrangement is such that there is provided means of restraining a shaft against reversible rotation and automatically removing the no-back restraint to allow reverse rotation.

It is a further object of this invention to provide a latch having automatic gear shift linkage connecting a

2

stored energy power source (spring bungee) to an operator shaft, which automatically shifts during shaft rotation to provide maximum output torque through the effective range of operation and minimum output torque through the ineffectual portion of the stroke and wherein the gear shift operation is accomplished by means of a single unstable link.

It is another object of this invention to provide a latch having automatic reset triggering means including means for holding a stored energy device in a cocked position, releasing this energy device when triggered for actuation, and automatically resetting for recocking.

Briefly stated, the invention comprises a crankshaft having a pin portion eccentric with the shaft. A latch member in the form of a hook is mounted for rotation upon the pin portion, with the crankshaft arranged to move the hook to the latched position during rotation of the shaft in a first direction and to move the hook to the unlatched position during rotation of the shaft in the opposite direction. It also includes a power package, such as a spring bungee, operably connected with the shaft for exerting a torque force to rotate the shaft in the first direction. Means are also provided for rotating the shaft in the opposite direction to thereby move the hook to the unlatched position and simultaneously store energy in the spring. Trigger means are provided for holding the spring with the stored energy and in the unlatched or cocked position releasing the spring when triggered for actuation to move the hook to the latched position and for automatically resetting for recocking.

Certain embodiments of the invention may also include automatic gear shift linkage means connecting the power spring bungee to the shaft which automatically shifts during shaft rotation to provide maximum output torque through the effective range of operation and minimum output torque through the ineffectual portion of the stroke. It may also include a no-back pawl which while restraining the shaft against reversible rotation is arranged for automatic disengagement, which disengagement is effected during rotation of the shaft in the opposite direction. The sequential triggering arrangement provides proper hook position before energy is released. Also included is a mechanical arrangement which provides means of locking in stored energy in a power device with more than one cocking stroke of an operating handle to reduce the operating force and automatically disconnects the driving pawl from the ratchet to remove interference during power release operation.

While the specific embodiment is directed to an automatic latch used to secure the command module to the lunar module of the Apollo spacecraft, it may be used for automatic coupling of remote controlled equipment such as Telestar satellite power package additions, space station assembly, nuclear power operations, deep ocean equipment construction, sea rescue or salvage operations, etc. Moreover, some of the novel features may be used singly or in various combinations.

**BRIEF DESCRIPTION OF THE DRAWINGS**

Reference to the drawings will further explain the invention wherein like numerals refer to like parts and in which:

FIG. 1 is a perspective view of the end of the command module docking ring of a space vehicle, showing twelve latches of this invention mounted thereon in pairs.

FIG. 2 is a side view of the latch assembly having the docking rings of the command module and lunar module in dotted line.

FIG. 3 is a front elevation view of the latch with a portion of the cocking handle partially broken away.

FIG. 4 is a view similar to FIG. 3 with the cocking

handle removed and a portion of the latching hook removed.

FIG. 5 is an isometric and partially exploded view of the latch assembly.

FIG. 5A is an enlarged portion of the hook and hook pawl shown in FIG. 5, but rotated 90°.

FIGS. 6, 7 and 8 are sectional views taken generally along lines 2A—2A of FIG. 3, and show the operation of the automatic gear shift linkage in sequence.

FIGS. 9—14 are generally fragmentary sectional views taken generally along lines 4—4 of FIG. 3 and showing the multiple stage cocking and automatic drive pawl disconnect mechanism in sequence.

FIGS. 15—17 are fragmentary sectional views generally taken along lines 5—5 of FIG. 3 and showing the automatic no-back ratchet disengagement in sequence.

FIGS. 18—20 are sectional views taken generally along lines 3—3 of FIG. 3 showing the automatic reset triggering mechanism in sequence.

FIG. 21 is generally a view taken generally along line 21—21 of FIG. 18.

FIG. 22 is an isometric view of the main housing of the invention showing most of the moving parts removed therefrom.

FIG. 23 is generally a horizontal sectional view taken through the main crankshaft.

FIG. 24 is a sectional view similar to FIG. 9, but along a line nearer the end of the latch.

#### DESCRIPTION OF THE PREFERRED EMBODIMENT

Referring now to FIG. 1, the end section of docking ring 11 of the command module of the Apollo spacecraft has twelve latches designated by the numeral 12 mounted in pairs about the circumference thereof. Each of the latches 12 has a handle 13 which is arranged for pivoting downward and radially inwardly, the same being shown in FIG. 1 in the actuated position. A spring bungee 14 is mounted therebeside with a latch hook 15 shown in the actuated position and facing generally outwardly and adapted for engagement with a mating docking ring on the lunar module (not shown). Docking ring 11 has a pair of annular seals 16 to effect sealing between the member to be latched by hooks 15, to provide a seal between docking ring 11 and lunar module docking ring 17, as shown in dotted line in FIG. 2, for example. The latch mechanism of this invention is generally included in a housing designated by the numeral 18 which is arranged for attaching by any convenient means, such as threaded fasteners, to docking ring 11.

Referring now to the drawings generally and FIG. 5 particularly, handle 13 is pivotally mounted by a pin 20 passing through pin holes 96—98 of housing 18, for rotation through an angle of approximately 100°. Handle 13 is arranged for return to the original starting position, as shown in dotted form, by means of a handle return bungee assembly 21 which is connected to a rod 22 which in turn is connected to bungee support 23 at an angle, which support is shown in FIG. 3 and which is mounted on pin 20, to thereby provide a biasing force to urge handle 13 to return to the starting position. The upper end of bungee assembly 21 is connected to transversely extending pin 26 on the back side of handle 13, as seen in FIG. 3, and on which is also mounted a pivotal handle latch plate 24 which, when depressed toward handle 13 and against the bias of spring 19, causes handle latch 25 connected therewith (as shown in FIG. 5) to rotate generally upwardly.

Handle 13 also has pivotally connected thereto a strap 27, the upper end of which is provided with an elongated slot 28 in which is received pin 29 connected to the back side of hook 15 such that downward rotation of handle 13 retracts hook 15 after a distance of free travel provided by slot 28. Hook 15 is also urged to the latched or upward position by means of spring 31 mounted on spring rod 32, the lower end of which is pivotally mounted on pin 20. The upper end of spring 31 is similarly supported by rod

33 pivotally connected to hook 15, as seen in FIGS. 3 and 18.

Handle 13 also has pivotally attached thereto a driving link 34 mounted on pivot pin 38, with the other end of link 34 being connected to driving crank 35 which is mounted for rotation on crankshaft 37. Crankshaft 37 is provided with an intermediate pin portion 36 that is eccentric with respect to crankshaft 37, as best seen in FIGS. 5 and 23, and during rotation of crankshaft 37 the axis of pin portion 36 is caused to move through an arc laterally spaced from the axis of rotation of crankshaft 37.

Crank 35 has mounted on the side thereof connecting means in the form of driving pawl 39 which is pivotally connected thereto and is biased downwardly by spring 40 the upper end of which is also pinned to crank 35. Pawl 39 is arranged to engage the first tooth 41 and the second tooth 42 of a ratchet 43 which is mounted for rotation on crankshaft 37. Ratchet 43 also has a row of smaller teeth 44 and first and second detents designated by the numerals 45 and 46 respectively. Teeth 44 are arranged to be engaged by no-back pawls 47, shown in FIG. 4, the operation of which will be explained in further detail hereinafter. Ratchet 43 is also provided with an auxiliary release notch 57 forward of detent 45 and a circumferential slot 48.

Detents 45 and 46 are arranged to be sequentially engaged by roller 91 mounted in the lower leading edge of power bungee release bell crank 49 which is mounted for rotation on a pin (not shown) mounted in housing 18, and with the upper arm thereof connected to a toggle linkage 50, the opposite end of which is pivotally connected to another bell crank 51 which is mounted on pin 52 and has an arm 53 which is biased upwardly by spring 54. Pin 52 is mounted for rotation in housing 18 and has bell crank 51 splined thereto on one end and power bungee release arm 55 splined to the other end. Arm 55 is arranged for contact by Allen-set screw 56 on the forward side of hook 15. Hence, when arm 55 is contacted by set screw 56, the toggle linkage arrangement is such that the forward lower arm of bell crank 49 is pivoted upwardly from engagement with detent 45 or detent 46.

In the retracted position, hook 15 has a travel of approximately 16° as shown in FIG. 5. Hook 15 is also arranged to be retained in the retracted position by hook pawl 58 which engages lug 59 connected with hook 15 as shown in FIG. 5A. Referring now to the upper right-hand corner of FIG. 5 and FIGS. 18—21, a portion of the trigger means of the invention will now be described. It includes a trigger 61 having a forward end which is arranged for contact by lunar module docking ring 17, as shown in FIG. 2, and is pivoted on pin 62 and has a rearward hook portion 63, which is arranged for engagement by handle latch 25 connected to handle 13. Trigger 61 is in the form of a bell crank mounted on pin 62 and has a rearwardly extending arm 64 which is arranged for biasing trigger 61 upwardly as shown in FIG. 5. When the forward end of trigger 61 is depressed, it lifts upwardly on arms 64, thereby drawing upwardly hook release rod assembly 67 which is pivotally attached thereto.

Trigger rod assembly 67 also has a manual release lever 68 which will be explained in greater detail hereinafter. The trigger means also includes a microswitch 69 which is arranged to provide an electrical output when the same is contacted by switch bell crank 70, which is arranged to be depressed into contact with switch 69 by contact with an Allen-set screw (not shown), in the forward or leading edge of hook 15, when hook 15 moves to the closed position. A cam lever 71 is attached to bell crank 70 and serves a dual purpose. Its primary function is a cam arranged in relation with the aforesaid Allen-set screw such that three separate motions are sensed before actuation of switch 69; (1) safe indication on crew's display panel is indicated when hook 15 is in position over lunar module ring, (2) hook 15 must be drawn down to indicate preload, and (3) trigger 61 must be in down position, indicating lunar

5

module ring in docked position (to eliminate the possibility of a false "safe" indication should a latch actuate prematurely). The second function of cam lever 71 is to act as a spring-loaded override to protect micro-switch 69 from overload by providing additional over-travel.

Referring now to the right side of FIG. 5, biasing means are shown for rotating crankshaft 37 and to store energy, which means are in the form of spring bungee 14 which is arranged for attachment to housing 18 as shown in FIG. 2 by integral trunnion shafts 71 on bungee 14 and housing clip 72. The automatic shifting means by which bungee 14 is connected to rotate cam crankshaft 37 will be explained hereinafter.

It is to be understood that the various parts shown in FIG. 5 are arranged for mounting and operation in housing 18, which is best shown in FIG. 22. For example, crankshaft 37 shown in FIG. 23 is arranged to be received in the annular openings 114-117 shown provided in the upstanding webbs 126-129 of housing 18, with appropriate bearings being provided.

#### AUTOMATIC GEAR SHIFT LINKAGE

Referring now to FIGS. 6, 7 and 8, details and operations of the automatic gear shift and linkage will now be explained in greater detail. In FIG. 6, hook 15 is shown in the latched position engaging lunar module docking ring 17 which is held against command module docking ring 11. Spring bungee 14 is in the form of a cylinder having a piston 74 mounted for movement therein and is biased upwardly by a pair of springs 75 and 76 and is connected to rod 77 for movement downwardly as shown. The lower end of rod 77 is connected to one end of an automatic gear shift linkage in the form of an unstable shifting lever link 79 by pin 80. The other end of link 79 is pivotally connected by pin 81 to an enlarged portion 83 of crankshaft 37 for rotation therewith. The center of rotation of enlarged portion 83 and crankshaft 37 is designated by the numeral 84. The axis of rotation of hook 15 is shown by the numeral 85. Enlarged portion 83 of crankshaft 37 is provided with a hollowed out portion forming stops 87 and 88 which are arranged to engage generally downwardly extending lug 89 attached to link 79, with the limit of movement of link 79 being controlled by stops 87 and 88.

FIG. 6 shows the actuated position of hook 15 with springs 75 and 76 exerting an upward bias on piston 74 which draws rod 77 upwardly which in turn causes enlarged portion 83 of shaft 37 to have a torque force applied thereto in a first or clockwise direction as shown in FIG. 6 and with a draw down force being applied to hook 15.

FIG. 7 shows hook 15 in the mid-cocked position with shifting lever link 79 in the on-center shifting position and piston 74 being drawn downwardly thereby to provide stored energy in spring 75 and 76.

FIG. 8 shows the full cocked position of hook 15 with shifting link 79 in the over-center shifted position and lug 89 contacting stop 87. It is to be understood that springs 75 and 76 may be preloaded to provide the desired pull down force on hook 15, to thereby provide a continuous clockwise torque on shaft 37 as viewed in FIGS. 6, 7 and 8.

In the FIG. 6 position, shifting lever link 79 is held in its high mechanically advantaged position by spring bungee 14 force. As shaft 37 is rotated counterclockwise, shifting lever link 79 position relative to shaft 37 is maintained until the center of pin 80 passes over the center of line of action of spring bungee 14 as shown in FIG. 7, at which point shifting lever link 79 pivots about pin 81 until lug 89 engages stop 87. This new position is maintained as the counterclockwise rotation of the shaft 37 is continued to the fully cocked position. Thus, the maximum stored energy is provided by the minimum input force. When shaft 37 is released from the cocked position, as will be explained hereinafter, the stored energy in bungee 14 rotates enlarged portion 83 and

6

shaft 37 clockwise as shown in FIGS. 6-8. The pull down force of hook 15 is minimum through the ineffectual portion of its stroke and automatically shifts to provide the maximum output at the full down position.

Thus, this means of connecting the bungee 14 to the operating shaft 37 through the gear shift linkage described provides the capacity of conserving most of the stored energy in bungee 14 through the ineffectual over-travel portion of the stroke for distribution through the remaining effective stroke. This offers a minimum size power package with a minimum input operating force and a maximum hook draw down force through the required range. For purposes of convenience, shifting lever link 79 may sometimes be referred to herein as an unstable link.

#### MULTIPLE STAGE COCKING AND AUTOMATIC DRIVE PAWL DISCONNECTION MECHANISM

Referring now to FIGS. 9-14 and 24, the operation of the multiple stage cocking and automatic drive pawl disconnect mechanism will be discussed. This portion of the device provides means for locking in stored energy in a power device with more than one cocking stroke of operating handle 13 to reduce the operating force and automatically disconnecting the driving pawl 39 from ratchet 43 to remove interference during power release actuation of hook 15. The operating force is reduced by utilizing more than one operating stroke of handle 13 and the arrangement is such that no separate action is required to disengage driving pawl 39 prior to actuation of hook 15.

FIGS. 9 and 24 show the apparatus in the actuated position. Shaft 37 has ratchet 43 splined thereto. Ratchet 43 is spring loaded by operation of bungee 14 to provide counterclockwise bias thereto as shown in FIGS. 9-14 and 24. Handle 13 is spring loaded by operation of bungee assembly 21, previously explained, to retract to the vertical position shown. Drive pawl 39 is lifted to the raised and non-operating position by contact with the support surface of housing 18, as shown. The functioning of the mechanism in sequence will now be described. During the first stroke, and at the beginning of that stroke, drive pawl 39 moves away from contact with the support surface of housing 18 and is caused to rotate by spring 40 to engagement with the first tooth 41 on ratchet 43. Drive crank 35 which is mounted for rotation on crankshaft 37 idles through an angle of approximately 10° until drive pawl 39 engages the first tooth 41, as shown in FIG. 10. During the remainder of the first stroke, as shown in FIGS. 10 and 11, ratchet 43, pin portion 36 and crankshaft 37 are rotated until the roller 91 mounted in the leading edge of the pawl arm of crank 49 engages first detent 45 of ratchet 43. Crankshaft 37, pin portion 36 and ratchet 43 are held in the intermediate cocked position by roller 91 until handle 13 is retracted to the point that driving pawl 39 engages second tooth on ratchet 43, as shown in FIG. 12.

During the second stroke of handle 13, ratchet 43, pin portion 36 and crankshaft 37 are again rotated in the clockwise direction, as shown in FIGS. 9-14, until roller 91 of crank 49 engages second detent 46 of ratchet 43. The apparatus is now in the fully cocked position. Toggle link 50 is in a safe over-center position, as shown in FIG. 13, and the power exerted by bungee 14 can be released only by normal operation of the power release bell crank 49. The apparatus remains in the fully cocked position while handle 13 is retracted to the vertical position, as shown in FIG. 14. Driving pawl 39 is lifted to clear the path of rotation of ratchet 43 during actuation of hook 15 to the latched position.

#### AUTOMATIC NO-BACK RATCHET DISENGAGEMENT

The next portion of the device which will be explained is the portion which provides means of restraining shaft 37 against reversible rotation and it includes means for

automatically removing the no-back restraint to allow reverse rotation thereof. This means is best shown in FIGS. 15, 16 and 17. As stated previously, drive crank 35 is mounted for free rotation on crankshaft 37 and ratchet 43 is splined to crankshaft 37. FIG. 15 shows the apparatus in the actuated position with hook 15 latched. No-back pawls 47 are engaged with ratchet teeth 44 which holds crankshaft 37 in the irreversible position. When handle 13 is pulled, the initial free travel of drive crank 35 causes the arcuate shaped ramp 92 attached to crank 35 to engage the cam surface 93 of no-back pawls 47 and lift pawls 47 from engagement with ratchet teeth 44, as shown in FIG. 16. Pin portion 36 and shaft 37 are now free for rotation to the cocked position shown in FIG. 17. It is to be understood that no-back pawls 47 are mounted for rotation on pin 20 and are biased into engagement with teeth 44 by spring 95, which spring is compressed during actuation, as shown in FIGS. 16 and 17.

It will thus be observed that no separate action is required to disengage no-back pawls 47 from the ratchet 43. A single pull of operating handle 13 removes the no-back restraint and rotates shaft 37 from its irreversible position.

The purpose of no-back pawls 47 is to make latch 12 capable of withstanding externally applied loads in excess of the spring loads, as for example, bending loads across the command module and lunar module interface during a mid-course direction maneuver. Applied loads on hook 15 would tend to cause back-up of the mechanism and the spring bungee in the absence of no-back pawls 47. Each latch 12, as designed, will withstand approximately 12,000 pounds of pressure with the first 3,000 pounds being opposed by the operation of the spring bungee and the next 9,000 by the operation of no-back pawls 47.

#### AUTOMATIC RESET TRIGGERING MECHANISM

Referring now to FIGS. 18, 19, 20 and 21, the automatic reset triggering mechanism will be discussed. This particular arrangement provides means for holding a stored energy device, i.e. bungee 14, in a cocked position and releasing the energy thereof when triggered for actuation and automatically resetting and recocking. It has a self escape means for the reset as will be described hereinafter.

FIGS. 18 and 21 show hook 15 in the retracted and cocked position. Trigger 61 is biased in a counterclockwise position, as shown in FIG. 18, by operation of spring 65 and arm 64 is biased downwardly. Trigger rod assembly 67 is connected at an intermediate point by pin 101 to spring bungee 102 the other end of which is connected by pin 103 to housing 18, whereby rod assembly 67 is biased generally to the right as shown in FIGS. 18-20. The lower free end of rod assembly 67 supports a roller 105 which is arranged to engage detent 106 of generally diamond shaped cam 107 and for engagement by cam ramp 108 formed in housing 18.

Cam 107 is mounted for pivoting about pin 110 and is biased downwardly by operation of spring 111. Cam 107 has pivotally connected thereto toggle link 112 which in turn is pivotally connected to toggle crank 113 to which is connected hook pawl 58 for rotational movement therewith. In FIG. 18 pawl 58 is shown engaging lug 59 which is attached to hook 15, also as shown in FIG. 5A. Hook 15 is mounted for rotation about shaft pin portion 36, as shown in FIG. 23.

FIGS. 18 and 21 show the apparatus in the cocked position. The length of trigger rod assembly 67 is adjusted to trigger at a predetermined position. Toggle link 112 is in the over-center position to insure positive engagement of pawl 58. Hook 15 is released when trigger 61 is depressed to the release position shown in FIG. 19. Rod roller 105 rides up ramp 108 and escapes from cam detent 106 when trigger 61 is fully depressed, and cam 107

is then free to reposition pawl 58 for subsequent recocking, as shown in FIG. 20. The mechanism now may be recocked even though trigger 61 is depressed (lunar module docked) when hook 15 is pulled back and pawl 58 is free to reengage under hook lug 59.

#### AUXILIARY RELEASE

In the event of excessive lunar module ring distortion, for example, which would prevent hook 15 from disengaging from the lunar module ring during the first stroke of operating handle 13, auxiliary release means are provided to cock hook 15. These means include an auxiliary release crank in the form of cam blade 124 mounted for rotation on pin 20 adjacent pawls 47, as best seen in FIGS. 5 and 24. Cam blade 124 has attached to the rearward side thereof an auxiliary release button 123 also shown in FIGS. 3 and 24. The forward end of cam blade 124 is arranged to be received in slot 48 of ratchet 43 and to be engaged by the forward portion of ratchet 43 forming first detent 45 during rotation of ratchet 43. Cam blade 124 also has attached thereto and supports therebeside auxiliary pawl 125 which is arranged to engage auxiliary release notch 57 which is generally forward of first detent 45 of ratchet 43. Auxiliary pawl 125 is normally biased to the non-engaging position by operation of spring 121, the upper end of which is supported by upper rod 120 which is pivotally attached to a portion of housing 18 and lower rod 122 which is pivotally connected to a portion of cam blade 124. As pressure is applied to button 123, cam blade 124 is moved into recess 48 causing movement thereof to the over-center position such that spring 121 applies pressure to engage auxiliary pawl 125 against ratchet 43.

At this point, handle 13 may be rotated downwardly through the first stroke until auxiliary pawl 125 engages auxiliary release notch 57 of ratchet 43. In this position, auxiliary pawl 125 will hold shaft 37 in the mid-cocked position.

On the second stroke of handle 13, a portion of ratchet 43 will contact the forward edge of cam blade 124 to cam the same backwardly to the original position where it will be held in that position by the operation of spring 121. Thus, there is provided safety means for insuring that hook 15 can be retracted under certain adverse conditions as described above.

Manual release lever 68, shown in FIG. 5, is splined to a pin, the opposite end of which is connected for rotation with cam 107. Hence, by lifting upwardly on manual release lever 68, cam 107 is rotated upwardly and the hook 15 is then released. In addition, switch bell crank 70, shown in FIG. 5, is arranged for rotation with bungee 102, and the arrangement is such that bell crank 70 contacts additional contact means on switch 69 to reflect the various positions of the apparatus as sensed by the position of bungee 102.

#### OPERATIONAL SEQUENCE

The operating sequence of the latch mechanism will now be described. Hook 15 is moved to the cocked position by two full strokes of operating handle 13. Handle 13 is released by depressing latch plate 24 which disengages handle latch 25. At the beginning of the first stroke of handle 13, driving crank 35 idles through an angle of 10°. This initial travel disengages no-back pawls 47 from ratchet no-back teeth 44 (providing an irreversible clutch) and engages driving pawl 39 with ratchet 43. During the remainder of the first stroke, hook 15a is lifted approximately one-half of its vertical travel and is rotated backwardly approximately 16° for disengagement from lunar module docking ring 17. Hook release pawl 58 engages lug 59 of hook 15. Spring bungee 14 is compressed approximately one-half its stroke. Bungee release roller 91 on bell crank 49 is engaged in the first detent 45 on ratchet 43. In addition, switch bell crank 70 is released from engagement with the contact of switch 69.

During the second stroke of handle 13, hook 15 is lifted to its full vertical travel. Bungee 14 is extended to its full stroke. Bungee release roller 91 of bell crank 49 is engaged in the second detent 45 on ratchet 43. Handle 13 then free wheels upwardly by operation of bungee assembly 21 to rest against the retracted hook 15. When latch 15 is in the full cocked position, toggle link 112 (which is operationally connected to hook pawl 58) and link 50 (which is connected to power bungee release bell crank 49) are both in a safe over-center position and can be operated only by normal operation.

Latch 12 is actuated to the latching position, either by depressing trigger 61 or by rotation of manual lever 68, as discussed above. During such triggering, hook pawl 58 disengages from hook 15. Hook 15 then rotates to the vertical position over lunar module docking ring 17. Handle 13 follows hook 15 and rotates to the vertical position and lifts driving pawl 39 from engagement with ratchet 43. Bungee release roller 91 in the forward end of bell crank 49 disengages from the second detent 45 of ratchet 43. Released energy in bungee 14 rotates shaft 37 and pin portion 36 which draws hook 15 down on lunar module docking ring 17 with approximately 3,000 pounds of clamping force per latch, and no-back pawls 47 are engaged with ratchet teeth 44. Switch 69 is actuated by the arm of bell crank 70 and handle latch 25 is engaged with hook portion 63 of trigger 61.

Further modifications and other embodiments will be apparent to those skilled in the art in view of the foregoing description. It is to be understood that this invention may be utilized for automatically coupling two members other than space vehicles.

What is claimed is:

1. A readily releasable latch assembly for securing a pair of members in assembled relationship including in combination:

- a housing attached to one of the members;
- a rotatable shaft journaled in said housing, said shaft being in the form of a crankshaft having a pin portion eccentric with the shaft portion;
- a stored energy source operably connected with said shaft portion for exerting a torque force to rotate said shaft in a first direction;
- an unstable link having one end connected to said shaft portion and the other end operably connected to said stored energy source;
- a latch member operably connected with said pin portion for movement to the latched position during rotation of said shaft in said first direction, the latch contacting the other of said members and maintaining said pair of members in assembled relationship; and,

unlatching means for rotating said shaft counterclockwise to said first direction to disengage said latch from contact with said member.

2. The invention as claimed in claim 1 including:

trigger means for retaining said latch member in the unlatched position and releasing said latch member for movement to the latched position at predetermined times.

3. The invention as claimed in claim 2 wherein:

said energy sources is in the form of a bungee spring assembly.

4. The invention as claimed in claim 2 wherein said trigger means includes:

- a pawl arranged to engage and hold said latch member in the retracted position;
- and, means for disengaging said pawl at predetermined times.

5. The invention as claimed in claim 4 wherein said disengaging means includes:

- a cam mounted for pivoted movement through a plane generally normal to said shaft;
- and, a toggle linkage connecting said pawl and said cam.

6. The invention as claimed in claim 5 including:

a pivoted trigger positioned for contact at the forward end thereof by the member to be latched by said latch member;

and, a trigger rod pivotally connected to the rearward end of said trigger, said rod having a lower free end supporting a cam follower, with said cam follower being arranged to engage and pivot said cam to the pawl disengaging position when said trigger is actuated.

7. The invention as claimed in claim 6 including:

a spring connected to said cam and arranged to pivot said cam to the pawl engaging position after said cam is released by said cam follower.

8. The invention as claimed in claim 2 including:

means for sensing the latched condition of said latch member and generating a signal indicating said latch condition.

9. The invention as claimed in claim 6 wherein said unlatching means includes:

a ratchet connected with said shaft for rotation generally therewith;

a drive member mounted for rotation through an arc extending generally about said shaft;

and, coupling means for coupling said drive member with said ratchet during rotation of said drive member in said opposite direction.

10. The invention as claimed in claim 9 wherein:

said coupling means includes a drive pawl operably connected with said drive member for rotation therewith and arranged to engage said ratchet during movement of said drive member in said opposite direction and for disengagement from said ratchet during movement of said drive member in said first direction to a retracted position.

11. The invention as claimed in claim 9 including:

a power holding pawl arranged to engage said ratchet and hold said ratchet from rotation in said first direction when engaged;

and, means for disengaging said power holding pawl at predetermined times.

12. The invention as claimed in claim 11 including:

a toggle linkage connected to said power holding pawl and arranged to move to an over center position when said holding pawl is engaged with said ratchet in the fully cocked position.

13. The invention as claimed in claim 9 including:

a no-back pawl arranged to engage and hold said ratchet from movement in said opposite direction when engaged;

and, means cooperative with said drive member for automatically disengaging said no-back pawl during rotation of said drive member in said opposite direction.

14. In a latch assembly, the combination comprising:

a crankshaft having a pin portion eccentric with the shaft;

a latch mounted for rotation upon said pin portion, with said crankshaft arranged to move said latch to the latched position during rotation of said shaft in a first direction and to move said latch to the unlatched position during rotation of said shaft in the opposite direction;

a spring operably connected with said shaft for exerting a torque force to rotate said shaft in said first direction;

means for rotating said shaft in said opposite direction to thereby move said latch to the unlatched position and simultaneously store energy in said spring;

and, trigger means for holding said latch in the unlatched position and for releasing said latch for movement to the latched position at predetermined times.

15. The invention as claimed in claim 14 including:

an unstable link connected with said shaft at one end and operably connected with a spring assembly at the other end.

11

16. The invention as claimed in claim 14 including:  
trigger means for retaining said latch member in the  
unlatched position and releasing said latch member  
for movement to the latched position at predetermined  
times.

17. The invention as claimed in claim 14 wherein said  
means for rotating said shaft includes: 5  
a ratchet connected with said shaft for rotation gener-  
ally therewith;  
a drive member mounted for rotation through an arc 10  
extending generally about said shaft;  
and, coupling means for coupling said drive member

12

with said ratchet during rotation of said drive mem-  
ber in said opposite direction.

References Cited

UNITED STATES PATENTS

662,193	11/1900	Harsha	-----	24-66UX
2,984,176	5/1961	Sommer et al.	----	24-263.4X
2,984,880	5/1961	Danly et al.	-----	24-263.4X
3,346,929	10/1967	Webb	-----	24-263.4

DONALD A. GRIFFIN, Primary Examiner