

NATIONAL AERONAUTICS AND SPACE ADMINISTRATION
WASHINGTON, D.C. 20546

REPLY TO
ATTN OF:

April 5, 1971

TO: USI/Scientific & Technical Information Division
Attention: Miss Winnie M. Morgan

FROM: GP/Office of Assistant General
Counsel for Patent Matters

SUBJECT: Announcement of NASA-Owned
U.S. Patents in STAR

In accordance with the procedures contained in the Code GP to Code USI memorandum on this subject, dated June 8, 1970, the attached NASA-owned U.S. patent is being forwarded for abstracting and announcement in NASA STAR.

The following information is provided:

U.S. Patent No. : 3,416,106

Corporate Source : California Institute of Technology

Supplementary
Corporate Source : Jet Propulsion Laboratory

NASA Patent Case No.: XNP-08880

Please note that this patent covers an invention made by an employee of a NASA contractor. Pursuant to Section 305(a) of the National Aeronautics and Space Act, the name of the Administrator of NASA appears on the first page of the patent; however, the name of the actual inventor (author) appears at the heading of Column No. 1 of the Specification, following the words ". . . with respect to an invention of. . . ."

Gayle Parker

Enclosure:
Copy of Patent

FACILITY FORM 602	N71 24808	
	(ACCESSION NUMBER)	(THRU)
	4	00
	(PAGES)	(CODE)
	09	(CATEGORY)
	(NASA CR OR TMX OR AD NUMBER)	

N71-24808

Dec. 10, 1968

JAMES E. WEBB
ADMINISTRATOR OF THE NATIONAL AERONAUTICS
AND SPACE ADMINISTRATION
BROADBAND MICROWAVE WAVEGUIDE WINDOW
Filed Dec. 27, 1966

3,416,106

FIG. 1

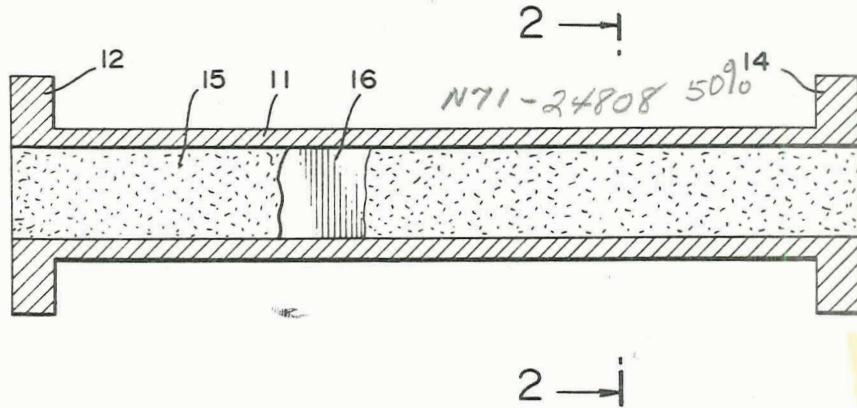
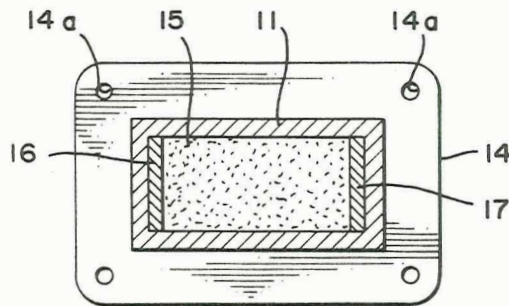

FIG. 2



CHARLES T. STELZRIED
DONALD L. MULLEN
INVENTORS

BY

J. H. Warden
ATTORNEYS

1573

1

3,416,106
BROADBAND MICROWAVE WAVEGUIDE
WINDOW

James E. Webb, Administrator of the National Aeronautics and Space Administration with respect to an invention of Charles T. Steizried and Donald L. Mullen, both of La Crescenta, Calif.

Filed Dec. 27, 1966, Ser. No. 605,094
5 Claims. (Cl. 333—98)

The invention described herein was made in the performance of work under a NASA contract and is subject to the provisions of Section 305 of the National Aeronautics and Space Act of 1958, Public Law 85-568 (72 Stat. 435; 42 USC 2457).

This invention relates to microwave waveguides and, more particularly, to a broadband microwave waveguide window.

In microwave waveguide applications in adverse environments, various techniques have been employed to protect the waveguides. For example, in waveguide installations in combination with cryogenic applications, due to the low temperatures present in such applications, water condensation from the atmosphere often occurs on the waveguide windows leading to the cryogenic equipment. To prevent such water condensation, the waveguide window may be filled or sealed with a dielectric material. However, such material produces a mismatch which reduces the bandwidth of the frequencies which can propagate through the window.

The mismatch effect of the dielectric material is to shorten the height of the waveguide which is analogous to a distributed capacity. Such mismatch effect can be compensated without reduction of bandwidth by customizing the waveguide, and providing a section with reduced width. However, the cost of such customized sections may be too great. Attempts have been made to compensate for the effect of dielectric material in a standard section with the use of tuning slugs. However, the use of such slugs has been found to be quite unsatisfactory since the slugs tend to reduce the bandwidth of the waveguide section. Thus, a need exists for a simple arrangement to compensate for the presence of a dielectric material filling a standard size section, without affecting the bandwidth thereof.

Accordingly, it is an object of the invention to provide such a simple arrangement.

Another object is to provide a broadband microwave waveguide window consisting of a standard dielectrically filled waveguide section.

A further object is to provide very simple and inexpensive means for compensating for the capacity distribution effect of dielectric material present in a standard waveguide section to prevent the narrowing of the bandwidth of the section.

These and other objects of the invention are achieved by narrowing the width of a standard waveguide section to be filled with a dielectric material with a pair of conductive metallic strips or shims placed adjacent each narrow wall of the section. Thus, the effective width of the standard section is reduced, with the dielectric material filling the total volume of the section of reduced width. Effectively, the shims increase the distributed inductance to compensate for the increase in the distributed capacitance, produced by the presence of the dielectric material.

The novel features that are considered characteristic of this invention are set forth with particularity in the appended claims. The invention will best be understood from the following description when read in connection with the accompanying drawings, in which:

FIGURE 1 is a longitudinal cross-sectional view of a

2

standard waveguide section filled with a dielectric material; and

FIGURE 2 is a cross-sectional view of the waveguide section shown in FIGURE 1 along line 2—2.

Referring to the figures in which like elements are designated by like numerals, there is shown a waveguide section 11, having end flanges 12 and 14 used to couple the section to other waveguide sections or equipment. In FIGURE 2, flange 14 is shown defining a plurality of apertures 14a, used to bolt flange 14 to a flange of another section or to the particular equipment such as a cryogenic system to which the section 11 is to be connected. When the section 11 is the last of a series of sections feeding microwaves in a particular application, the section 11 may be regarded as a microwave window.

The section 11 is shown filled with a dielectric material 15, the function of which is to fill the section, so as to prevent water condensation to form therein. The filling of the section with dielectric material is also useful to prevent corrosion and degradation of the electrical and thermal characteristics of the waveguide section produced by convective air currents which may occur in adverse environments in which the section may be placed. The window may also be used as a gas barrier in gas pressurized waveguide systems.

As previously indicated, the dielectric material increases the distributed capacity in the section, causing a distributed mismatch. Such mismatch can be compensated for by using a specially constructed section of reduced width. However, as indicated, this is undesirable since it increases the cost of the waveguide section. Tuning slugs have been used but were found to reduce the bandwidth of the section.

In accordance with the teachings of the present invention, the mismatch produced by the dielectric material is easily compensated for by the use of two conductive strips or shims, designated by numerals 16 and 17. These shims are placed next to the narrow sides of the section 11 and typically soldered in place. The thickness of the shims is dependent on the dielectric constant of the material 15 and the particular dimensions of the section 11.

In one actual reduction to practice, a standard waveguide section for the X-band, known as WR 90 of a length of several inches was used. The wide dimensions of the section are 0.900 inch wide by 0.400 inch high. A section without the shims was used with a dielectric material such as polystyrene having a relative dielectric constant of approximately 1.05. After the material hardened, the section was tested and found to have a Voltage Standing Wave Ratio (VSWR) which varied between 1.2 and 1.05 between the frequency range of 10.3 gc. and 10.5 gc. However, by using two metal shims, each placed next to one narrow wall of the section and soldered in place, the VSWR varied between 1.005 and 1.01 between 9.0 and 11.0 gc. This clearly indicates the bandwidth broadening effect produced by the use of the shims.

In practice, the shims are placed in the section before the dielectric material is poured therein. In general, the higher the dielectric constant of the material, the thicker the shims have to be.

From the foregoing, it should be appreciated that in accordance with the teachings of the invention, the presence of dielectric material in a standard size waveguide section is conveniently and easily compensated for by reducing the width of the section by means of electrically conducting metallic shims, rather than by tuning slugs or specially designed sections of reduced size. As previously indicated, a section filled with dielectric material may find particular use in applications where the section may be subjected to severe environment, such as the low temperature of cryogenic applications, which may cause water

to condense in the section. Other adverse environments may include salty ocean air which may affect waveguide sections in shipboard radar installations. Thus, the present invention is useful whenever a section is preferably filled to prevent such environments from affecting the performance thereof.

It is appreciated that those familiar with the art may make modifications in the arrangements as claimed without departing from the spirit of the invention. Therefore, all such modifications are deemed to fall within the scope of the invention as claimed in the appended claims.

What is claimed is:

1. In a waveguide section defining a waveguide channel having a predetermined height and width which are controlling the bandwidth of frequencies of a selected range of frequencies of microwaves which can propagate through said section, the improvement comprising:

a pair of electrically conductive strips positioned in said channels near two opposite sides thereof in electrical contact with said sides, to decrease the width of said channel, the height of each strip being equal to the height of said channel; and

a material with preselected dielectric constant filling said channel, the thickness of said strips being directly related to the dielectric constant of said material, said strips by reducing the width of said channel, substantially compensating for the effect of said material in said channel on the bandwidth of the frequencies which are to propagate through said channel.

2. The waveguide section as recited in claim 1 wherein said channel has a rectangular cross-section, said strips being held in electrical contact with the narrow sides of said channel to reduce the width thereof, to compensate for the effect on the bandwidth of frequencies of microwaves which can propagate through said channel by said dielectric material filling the channel.

3. In a waveguide section having a channel of standard selected height and width dimensions for a particular band of frequencies of microwaves which are to propagate therethrough, said section being subjected to an adverse environment capable of affecting the environment within said channel and thereby affect the propagation of microwaves therethrough, an improvement for minimiz-

ing the adverse effects on said section comprising:

a pair of electrically conductive strips of equal thickness placed in electrical contact with two opposite walls of said channel; and

a dielectric material of a selected dielectric constant filling said channel, said strips reducing the width of said channel by twice the thickness of each strip, the thickness being directly related to the dielectric constant of said material.

4. The improvement as recited in claim 3 wherein said channel has a rectangular cross-section and said strips are in electrical contact with the narrow walls of said channel to minimize the effect of the material on the bandwidth of microwave frequencies which can propagate through said material by reducing the width of said channel.

5. The method of modifying a standard waveguide section defining a channel of rectangular cross-section of standard height and width for a particular band of microwave frequencies which are to propagate therethrough, in order to minimize adverse effects of external environment on the propagation of said microwaves, the steps comprising:

placing a pair of electrically conductive strips in electrical contact with the narrow walls within said channel, the strips being of a height equal to the channel's height;

filling the channel with a liquid having a selected dielectric constant; and

permitting the liquid to harden to form dielectric matter filling said channel, the strips reducing the width of the channel from the standard width by an amount sufficient to compensate for the mismatch produced in said channel by the presence of the dielectric matter.

References Cited

UNITED STATES PATENTS

2,129,669	9/1938	Bowen	333—98
2,576,186	11/1951	Malter et al.	
3,001,160	9/1961	Trousdale.	

HERMAN KARL SAALBACH, *Primary Examiner.*

I. ALLAHUT, *Assistant Examiner.*