

N71-21822

Oct. 10, 1967

HUGH L. DRYDEN, DEPUTY  
ADMINISTRATOR OF THE NATIONAL  
AERONAUTICS AND SPACE ADMINISTRATION  
ELECTRON BOMBARDMENT ION ENGINE  
Filed Oct. 19, 1965

3,345,820

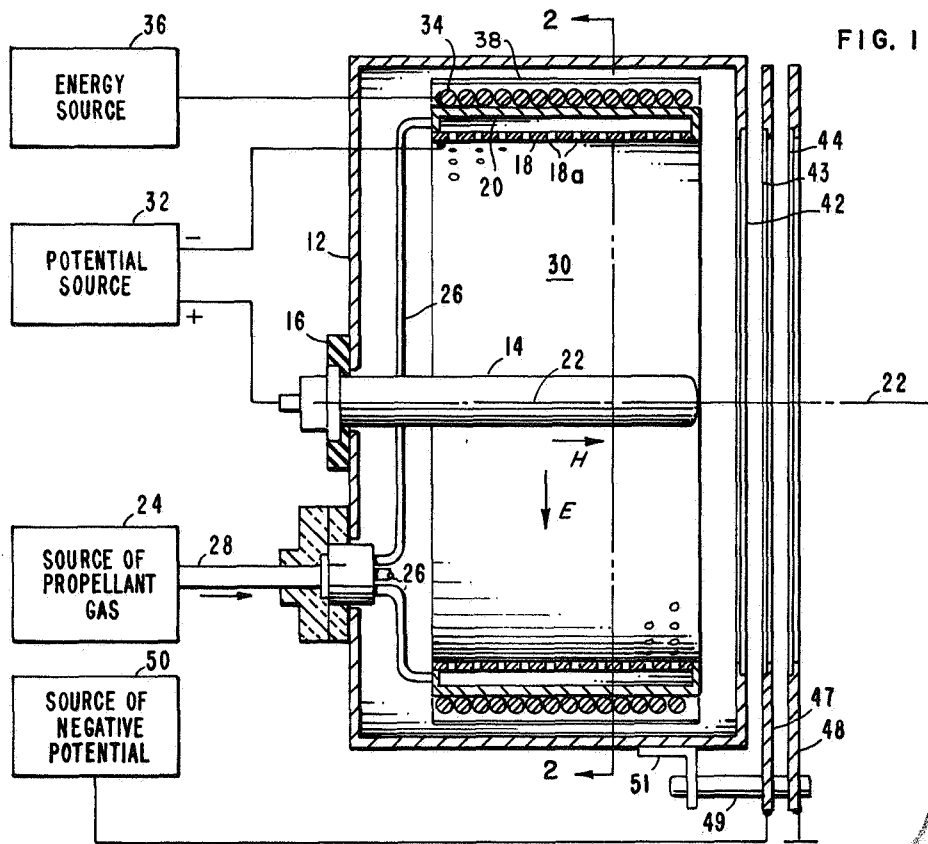

N71-21822 4090

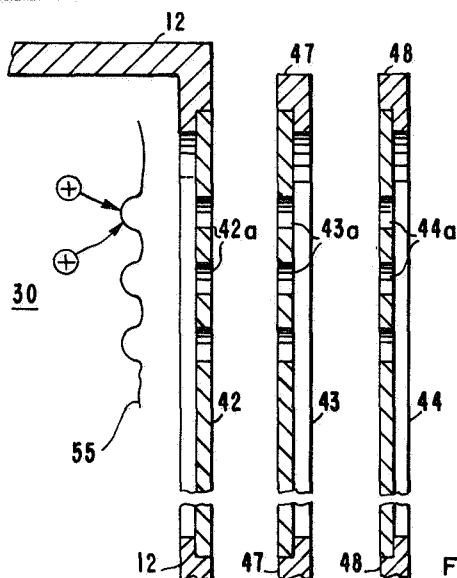

FIG. 3

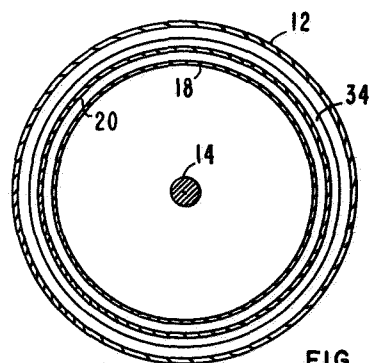

FIG. 2

INVENTOR.  
TOMMY D. MASEK  
BY *Atm & Coy*  
ATTORNEYS

1260

1

3,345,820

**ELECTRON BOMBARDMENT ION ENGINE**

Hugh L. Dryden, Deputy Administrator of the National Aeronautics and Space Administration, with respect to an invention of Tommy D. Masek, La Crescenta, Calif. Filed Oct. 19, 1965, Ser. No. 498,168  
8 Claims. (Cl. 60—202)

**ABSTRACT OF THE DISCLOSURE**

An ion engine in which an anode is centrally mounted in a housing, with a porous cathode coaxially mounted about the anode to define an ionization chamber. A potential source, connected to the anode and cathode, provides a radial electrical field in the chamber. A coil, wound about the cathode, serves to heat the cathode as well as provide an axial magnetic field perpendicular to the electrical field. Propellant gas is injected into the chamber through the cathode, continuously coating it to reduce its work function and to control the uniform spatial ion distribution within the chamber.

*Origin of the invention*

The invention described herein was made in the performance of work under a NASA contract and is subject to the provisions of Section 305 of the National Aeronautics and Space Act of 1958, Public Law 85-568 (72 Stat. 435; 42 USC 4257).

The present invention relates to an ion engine and, more particularly, to an improved electron bombardment ion engine.

One of the primary contemplated sources of propulsion in space is the ion engine. Basically in an ion engine a plasma comprised of neutral atoms of a propellant gas, electrons and ions is produced. The ions are extracted and accelerated in a selected direction and controlled to form an ion beam which provides the desired thrust. The relative simplicity, low power consumption and adaptability of the ion engine to several propellants account for the planned usage of such engines in future space exploration.

However, one of the major outstanding problem areas in such engines is their life-time capabilities. In presently-known ion engines, certain components, especially those associated with the production of the ions and the acceleration and shaping of the ion beam, have life expectancies which are considerably shorter than the length of certain presently planned space missions which will extend for 10,000 hours or more. Thus extensive research and developmental work is being directed to extend the life expectancy of ion engines.

It has been found that in electron bombardment ion engines the two elements which exhibit limited life expectancies are the element, known as the cathode, which is the source of electrons used to bombard neutral atoms of propellant gas and the element, known as the accelerating grid which accelerates the ions in a particular direction and controls the shape of the ion beam. It has been found that the non-uniformity of the spatial ion distribution in the plasma causes selective erosion of parts of the accelerating grid which greatly limits its life expectancy. Thus, the ability to reduce spatial ion distribution non-uniformity in electron bombardment ion engines is of major importance in extending the life expectancy of the engine. Also, a need exists for a cathode so constructed that it produces an adequate source of electrons over a lifetime compatible with the length of the space mission in which the engine is to be incorporated.

Accordingly, it is an object to provide a novel ion engine.

2

Another object is to provide a new ion engine in which ions are produced by electron bombardment.

A further object is to provide a new electron bombardment ion engine with a novel cathode arrangement for improving the life expectancy of the engine.

Still a further object is to provide a novel electron bombardment ion engine with an improved construction for improving the uniformity of the spatial ion distribution therein and the life expectancy thereof.

Yet a further object is the provision of a new electron bombardment ion engine with an improved construction to increase the uniformity of the spatial ion distribution therein, thereby increasing the ratio of the produced thrust to engine weight.

These and other objects are achieved by providing an electron bombardment ion engine with a radial electric field and an axial magnetic field oriented so that the uniformity of the spatial distribution of the ions in the engine is improved. Consequently, the element used to accelerate and control the shape of the ion beam is not subject to uneven erosion. As a result, the life of the accelerating element is increased. Also the engine includes a cathode construction, through which the propellant gas is fed into the engine so that the cathode can be operated with a high degree of efficiency, thus lengthening the life of the cathode as a source of ion-producing electrons.

The novel features that are considered characteristic of this invention are set forth with particularity in the appended claims. The invention itself both as to its organization and method of operation, as well as additional objects and advantages thereof, will best be understood from the following description when read in connection with the accompanying drawings, in which:

FIGURE 1 is a cross-sectional view of the novel ion engine of the present invention, the section being in a plane parallel to the axial direction of the engine;

FIG. 2 is a view taken along lines 2—2 shown in FIGURE 1; and

FIGURE 3 is an expanded view of a portion of the arrangement shown in FIGURE 1.

Attention is now directed to FIGURES 1 and 2 which are cross-sectional views of the engine of the present invention and a view along lines 2—2 respectively. The cross-section is in a plane parallel to the axial direction of the engine. As seen, the engine includes a cylindrical housing 12 in which a probe-like cylindrical anode 14 is centrally mounted. The anode is electrically insulated from the housing by an insulator 16. A cylindrically-shaped porous cathode 18 having a plurality of holes or apertures 18a and supported by a cylindrical cathode support member 20 is rigidly mounted within the housing so that the housing, anode, cathode and support member 20 have a common longitudinal axis designated in FIGURE 1 by numeral 22.

The support member 20 is shown coupled to a source of propellant gas 24, such as cesium, by means of a plurality of conduits 26 which are connected to the source by a main conduit 28. The propellant gas is supplied under a predetermined pressure and temperature to the support member 20 and therefrom is forced through the holes 18a in the porous cathode 18 into the chamber 30 of the engine.

The cathode 18 and anode 14, which in one actual reduction to practice were made of the refractory metals tungsten and molybdenum respectively, are connected to a potential source 32 so that a potential difference exists between the anode and cathode with the anode 14 being at the higher potential. The engine also includes a cathode heating element 34 which is shown comprising a coil coaxially wound around the cathode. The coil 34 which is connected to a source of energy 36 heats up the cathode to a temperature sufficient enough to cause electrons to

3

be separated therefrom. Since the anode is at a higher potential, the electrons are attracted toward it. As the electrons are separated from the cathode with sufficient energy which is proportional to the potential difference between the cathode and the anode, they collide with atoms of the propellant gas which are forced through the holes 18a into the chamber 30. The collisions result in the production of ions. Thus the chamber 30 contains neutral atoms of propellant gas, ions and free electrons, which together are often referred to in the art as plasma.

The coil 34, in addition to serving as a heating element to heat the cathode 18 so that electrons are separated therefrom, also serves as a source of a magnetic field which is produced due to the current flowing in the various loops of the coil. Representing the electric field produced by the potential difference between the anode and cathode by an arrow E, the magnetic field is represented by an arrow H. The polarity of the magnetic field is a function of the direction of electron current flow in coil 34. In the absence of the magnetic field, the electrons move in substantially straight lines between the cathode 18 and the anode 14. However due to the magnetic field, the electrons tend to rotate about the lines of magnetic flux of the field so that their mean free path is greatly increased. Actually, the electrons may be thought of as being trapped by the magnetic lines of flux and must depend upon collisions with gas atoms to be diffused to the anode. Consequently, the probability that an electron, separated from the cathode and moving to the anode, will strike a neutral atom of the propellant gas with sufficient energy to form an ion is greatly enhanced. The efficiency of heating the cathode is greatly increased by shielding the coil 34 with a radiation shield 38 so that a large portion of the energy from the coil 34 is used to heat the cathode.

From the foregoing, it is thus appreciated that the function of the heated cathode 18 is to supply electrons which ionize neutral atoms of propellant gas which is forced through the holes in the porous cathode. It has been found that by employing the arrangement as shown whereby an alkali gas, such as cesium, is forced through a heated porous cathode of a refractory metal, such as tungsten, some of the gas atoms tend to coat the cathode.

Briefly, some gas atoms coat the cathode for a short time. Then, due to the cathode's temperature, they are removed therefrom and new gas atoms are deposited on it. Thus the cathode is continuously being recoated by gas atoms which results in a reduction in the cathode metal's work function. Consequently, the cathode may be operated at lower temperatures to provide the required electrons for ionization of the propellant gas. The lower temperatures can be produced with less energy and therefore the engine can be operated more efficiently with lower power required. Also, the reduced temperatures result in an increase in the life of the heating coil 34.

In addition to the improved efficiency with which the novel engine of the present invention may be operated, the novel structure of coaxially mounting the cathode about the anode greatly accounts for the improved uniformity of the spatial ion distribution in the plasma produced therein. From the foregoing description in conjunction with FIGURES 1 and 2, it should be appreciated that since the electrons are supplied by the cathode and the neutral gas atoms which are to be ionized enter chamber 30 through the porous cathode, the largest concentration of atoms and electrons is initially near the cathode. Consequently, most ionization is produced very near the cathode. Thus the only way of obtaining ions and/or electrons near the anode is by means of diffusion, which occurs due to the density gradient of the ion and electron distribution. By mounting the anode 14 in the center of the engine and the cathode exterior thereto, the ions and electrons or plasma diffuses radially inwardly into a decreasing volume. The volume continuously decreases as the ions and electrons get closer to the anode. As a result, the spatial distribution of ions in the plasma attains a

4

relatively high degree of uniformity which contributes greatly to the increased life expectancy of the engine of the present invention.

Referring again to FIGURE 2, there are shown three grids designated by reference numerals 42, 43, and 44. The three grids hereafter also referred to as the screen grid, the accelerating grid, and the decelerating grid, are also shown in expanded form in FIGURE 3 to which reference is made herein. Each grid comprises in essence a disc-like metallic member with a plurality of apertures or holes which are designated in FIGURE 3 by the numeral of their respective grid with the subscript *a*. For simplicity, three apertures of each grid are diagrammed in FIGURE 3. As seen from FIGURES 2 and 3, the bias grid 42 is directly supported by the housing 12, while grids 43 and 44 are supported by grid supports 47 and 48, which are mounted on electrical insulators 49 coupled to housing 12 by a bracket 51. Grid 42 is maintained at the housing potential, while decelerating grid 44 is maintained at ground potential. When the engine is in a spacecraft, the ground is the same as the spacecraft ground. On the other hand, grid 43 is connected to a source of potential 50 which is negative with respect to ground in order to accelerate the ions from the engine and provide an ion beam which furnishes the desired thrust. The cathode 18 and housing 12 are maintained at a positive potential above ground, with the anode being at a slightly higher potential necessary to produce the field indicated by arrow E.

It is appreciated by those familiar with the art that as ionization continues, the plasma and the ions therein are pushed toward the grid 42, the apertures of which are the only openings of the chamber 30. The plasma approaches the grid 42 which, due to its potential being equal to that of the housing, causes the plasma to form a boundary or sheath 55. The exact shape of the plasma boundary at an aperture depends on the plasma density and the net accelerating potential. The only ions accelerated from the engine have crossed the boundary because of their random thermal velocities.

As ions are attracted by the grid 43, the boundary changes shape so that the ions which cross it are attracted out of the chamber 30 through the various grids and are focused to form a plurality of small ion beams which converge into a major ion beam after passing through the decelerating grid 44. The function of the latter grid is to bring the potential of the ion beam to ground potential so as to prevent the beam from returning to the engine. As is known by those familiar with the art, a neutralizer serving as a source of electrons need be provided to prevent space charge phenomena from affecting the thrust-producing ion beam.

It has been found that if the spatial ion distribution in the plasma is not uniform, the grids, especially the accelerating grid, is subject to non-uniform erosion of parts thereof. The erosion is produced by sputtering of the grid which occurs due to a charge exchange taking place when ions and neutral atoms which were attracted from the plasma collide. If the spatial ion distribution in the plasma is not uniform, the charge exchange process near the accelerating grid is not uniform. Consequently, the grid is subjected to non-uniform sputtering erosion which eventually results in a part of the grid eroding to the point of engine failure. The failure is generally exhibited by the inability of the eroded grid to focus the plurality of ion beams emerging through the apertures of grid 44 and combine them into a single thrust-providing ion beam.

However, in accordance with the teachings of the present invention by coaxially mounting the cathode about and exterior to the anode, the uniformity of the spatial ion distribution in the plasma is greatly increased. Consequently, the erosion of the grid 43 is more uniform which accounts for the increase in its life expectancy before failure.

5

From the foregoing, it should thus be appreciated that in accordance with the teachings of the present invention a novel ion engine is provided with the ions produced therein having a relatively uniform spatial distribution. This characteristic is mainly due to the novel cathode structure and arrangement wherein a porous cathode is mounted coaxially with and exterior to an anode. The propellant gas is forced into the engine chamber through the porous cathode, with ionization taking place adjacent to the cathode surface, and ionization diffusion occurring inwardly towards the anode in an ever-decreasing deionized volume. Herebefore, cesium was used as one example of a propellant gas and tungsten and molybdenum as the metals of the cathode and anode respectively. It should be appreciated however that other gas and metals known to those familiar with the art may be employed to practice the teachings disclosed herein. It should further be appreciated that those familiar with the art may make modifications in the arrangements as shown without departing from the true spirit of the invention. Therefore, all such modifications and/or equivalents are deemed to fall within the scope of the invention as claimed in the appended claims.

What is claimed is:

1. An ion engine comprising:

a housing having an open end;

anode means centrally mounted within said housing and extending toward said open end;

cathode means coaxially mounted in said housing about said anode means to define a chamber therebetween;

means for connecting said anode means and cathode means to a potential source for establishing a radial electrical field in said chamber with the anode means at a positive potential with respect to the cathode means, whereby electrons from said cathode means are attracted by said anode means;

source means for supplying a propellant gas into said chamber through said cathode means, whereby atoms of said gas are ionized by electrons from said cathode means, to form ions in said chamber; and

means disposed adjacent said open end for attracting the ions produced in said chamber and for focusing said ions into an ion beam.

2. The ion engine defined in claim 1 further including a coil coaxially wound about said cathode means for heating said cathode means to increase the free electrons provided thereby and for providing an axial magnetic field substantially perpendicular to said radial electrical field.

3. The ion engine defined in claim 2 wherein said cathode means is porous defining a plurality of apertures therein; and

means connecting said source means to said cathode means to introduce neutral atoms of said propellant gas into said chamber through the apertures of said cathode means.

4. The ion engine defined in claim 3 wherein said source means supplies said propellant gas so that said cathode means is continuously coated by atoms of said propellant gas to substantially reduce the temperature at which said cathode means produces free electrons of sufficient energy to ionize some of the neutral atoms of said propellant gas.

5. An ion engine comprising:

a cylindrical housing having one open end;

an anode centrally mounted within said housing and extending toward and substantially up to said open end;

6

a cylindrical cathode coaxially mounted about said anode, said cathode being porous having a plurality of apertures defined therein, said cathode and anode defining an ionization chamber therebetween;

means for establishing a radial electrical field between said anode and cathode, said anode being at a higher positive potential than said cathode;

a source of neutral atoms of a propellant gas;

means for supplying said neutral atoms of said gas into said ionization chamber through the apertures of said cathode;

coil means coaxially wound about said cathode to heat said cathode to a temperature sufficient to release electrons therefrom, said electrons having energy levels sufficient to ionize in said ionization chamber some of the neutral atoms supplied through said apertures with ions produced near said cathode diffusing inwardly toward said anode, said coil means providing an axial magnetic field as a function of an electrical current flowing therein to increase the mean free path of the electrons released from said cathode, said axial magnetic field being substantially perpendicular to said electrical field; and

grid means disposed adjacent said open end for focusing and accelerating ions produced in said ionization chamber to form a focused ion beam propagating in a direction away from the open end of said housing.

6. The ion engine defined in claim 5 wherein said grid means includes a first screen grid mounted at said open end, said first screen grid being at the potential of said housing, and a second accelerating grid partially disposed with respect to said first grid and being at a negative potential with respect to the potential of said housing, each of said first and second grids having a plurality of apertures, said second accelerating grid attracting ions in said ionization chamber thereto through the apertures of said first screen grid.

7. The ion engine defined in claim 6 wherein said cathode is at the housing potential level, and said grid means further includes a third grid at a ground potential substantially above the potential of said second grid but below the housing potential to reduce the potential of the ion beam propagating away from said housing to ground potential.

8. The ion engine defined in claim 7 wherein said housing, cathode and said first screen grid are at a first potential level above a ground potential level, said second accelerating grid is at a negative potential level with respect to said ground potential level and said anode is at a potential level above said first potential level.

#### References Cited

##### UNITED STATES PATENTS

2,809,314	10/1957	Herb	60—202 X
3,156,090	11/1964	Kaufman	60—202
3,159,967	12/1964	Webb	60—202
3,191,092	6/1965	Baker et al.	60—202 X
3,262,262	7/1966	Reader et al.	60—202

##### FOREIGN PATENTS

1,366,930	6/1964	France.
-----------	--------	---------

##### OTHER REFERENCES

Missiles and Rockets, Apr. 4, 1960, pp. 26 and 27 relied on.

CARLTON R. CROYLE, *Primary Examiner.*