



NATIONAL AERONAUTICS AND SPACE ADMINISTRATION
WASHINGTON, D.C. 20546

REPLY TO
ATTN OF: GP

October 15, 1970

TO: USI/Scientific & Technical Information Division
Attention: Miss Winnie M. Morgan

FROM: GP/Office of Assistant General
Counsel for Patent Matters

SUBJECT: Announcement of NASA-Owned
U.S. Patents in STAR

In accordance with the procedures contained in the Code GP to Code USI memorandum on this subject, dated June 8, 1970, the attached NASA-owned U.S. patent is being forwarded for abstracting and announcement in NASA STAR.

The following information is provided:

U.S. Patent No. : 3,258,831

Corporate Source : Marshall Space Flight Center

Supplementary
Corporate Source : _____

NASA Patent Case No.: XMF-03498

Gayle Parker

Enclosure:
Copy of Patent

FACILITY FORM 602	N71-15986	_____
	(ACCESSION NUMBER)	(THRU)
	<u>7</u>	_____
	(PAGES)	(CODE)
	_____	<u>15</u>
	(NASA CR OR TMX OR AD NUMBER)	(CATEGORY)

NASA-HQ

July 5, 1966

W. ANGELE ET AL

3,258,831

METHOD OF MAKING A MOLDED CONNECTOR

Original Filed May 12, 1961

2 Sheets-Sheet 1

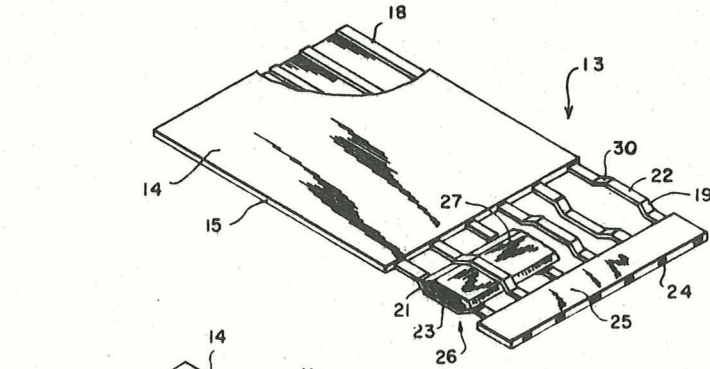

FIG. 1

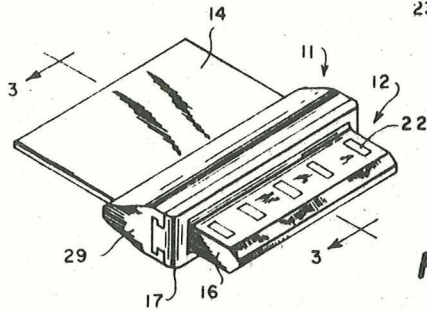

FIG. 2

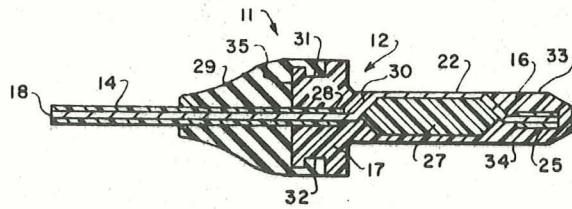

FIG. 3

WILHELM ANGELE
HANS G. MARTINECK,
INVENTORS

BY *James O. Harrell*
James O. Harrell

ATTORNEYS

N71-15986

July 5, 1966

W. ANGELE ETAL

3,258,831

METHOD OF MAKING A MOLDED CONNECTOR

Original Filed May 12, 1961

2 Sheets-Sheet 2

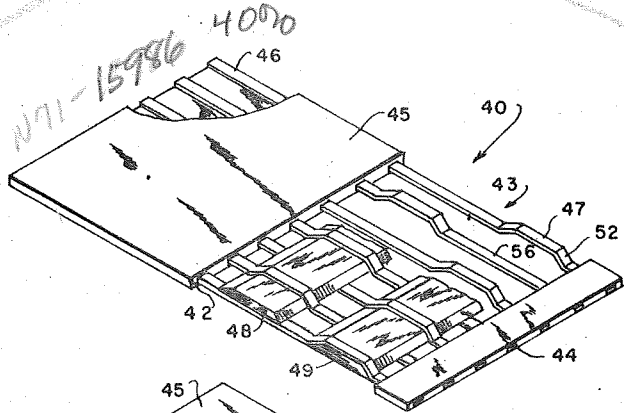

FIG. 4

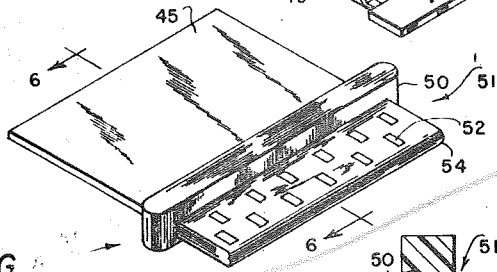

FIG. 5

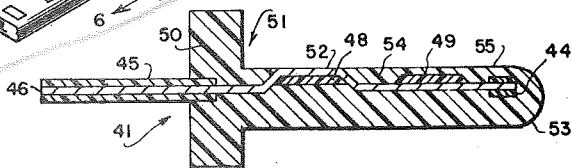

FIG. 6

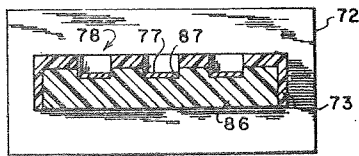

FIG. 8

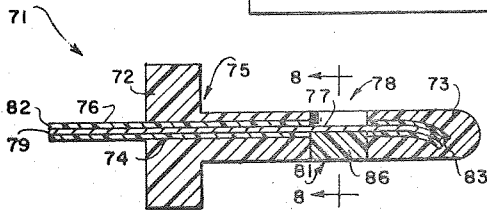

FIG. 7

WILHELM ANGELE
HANS G. MARTINECK
INVENTORS

BY

James O. Harrell

ATTORNEYS

946

1

3,258,831

METHOD OF MAKING A MOLDED CONNECTOR

Wilhelm Angele and Hans G. Martineck, Huntsville, Ala., assignors to the United States of America as represented by the Administrator of the National Aeronautics and Space Administration

Original application May 12, 1961, Ser. No. 109,789, now Patent No. 3,189,164, dated June 15, 1965. Divided and this application Sept. 14, 1964, Ser. No. 396,443
8 Claims. (Cl. 29—155.55)

The invention described herein may be manufactured and used by or for the Government of the United States of America for governmental purposes without the payment of any royalties thereon or therefor.

This application is a division of copending application Serial No. 109,789, filed May 12, 1961 and now United States Patent No. 3,189,164.

This invention relates generally to improvements in electrical connectors and the like and more particularly to a new and improved terminal insert connector for flat electric cables.

The bulky bundle of individual insulated wires used in electrically connecting the widely spaced electrical components mounted in space vehicles has recently been successfully replaced by flat, thin, flexible, flat-conductor cables. The single-plane construction of a flat electrical cable provides inherent economies in the limited space accommodations of space vehicles because it can easily be routed through narrow or restricted areas through which it would be impossible to install a conventional bundle of individual insulated wires. However, one of the most important problems encountered in using these flat electrical cables was providing their terminals with a connector which could be inserted or telescoped into a complementary mating receptacle either permanently mounted as part of the electrical component or on the terminus of an adjacent cable. The initial attempt to provide a suitable terminal connector consisted of a clip device which held a cable portion which had been stripped of insulation whereby the bared electrical conductors could contact the electrical contacts of a mating receptacle. However, this prior device was not successful because of its fragile construction and high current leakage between adjacent bare conductor surfaces. The present invention overcomes these prior difficulties by providing an improved terminal insert connector for flat electrical cables having a sturdy construction which is light, simple, easily handled, and has a low current leakage between the electrical contacts.

It is, therefore, an object of the invention to provide an improved terminal insert connector for electrical cables.

Another object is to provide a terminal insert connector for flat electrical cables which is sturdy and easily handled.

Still another object is to provide a terminal insert connector for flat electrical cables which has a low current leakage.

Yet another object is to provide an efficient method of making an improved terminal insert connector for electrical cables.

A still further object is to provide a method of making an insert connector for flat electrical cables which has a low current leakage.

Other objects and many attendant advantages of the present invention will be apparent from the following detailed description when taken together with the accompanying drawings in which:

FIGURE 1 is a perspective view with portions broken away of a flat electrical cable modified for the subsequent molding thereon of the improved insert connector;

FIGURE 2 is a perspective view showing the insert connector molded on the terminal portion of a flat electrical cable;

2

FIGURE 3 is a cross-sectional view of the insert connector taken along line 3—3 of FIGURE 2;

FIGURE 4 is a perspective view with portions broken away showing the terminal portion of a flat electrical cable modified for the subsequent molding thereon of the modified insert connector;

FIGURE 5 is a perspective view showing the modified insert connector on the terminal portion of a flat electrical cable;

FIGURE 6 is a cross-sectional view taken along line 6—6 of FIGURE 5;

FIGURE 7 is a cross-sectional view of another modified insert connector on the terminal portion of a flat electrical cable; and

FIGURE 8 is a cross-sectional view taken along line 8—8 of FIGURE 7.

An embodiment of the present invention herein disclosed by way of illustration is shown in FIGURES 1, 2, and 3. It consists of the male plug or insert connector 11 which has a T-shaped body 12 defined by a rear ridge portion 17 and an insert portion 16 integrally formed on the terminal portion 13 of a flat electrical cable 14. As shown, the cable 14 is composed of spaced, parallel, flat metal electrical conductors 18 extending along the longitudinal plane and axis of the cable 14 and a thin sheet of flexible dielectric plastic material 15 embedding the conductors 18. The insert portion 16 is adapted to be inserted into a receiving mating receptacle of a type illustrated in U.S. Patent 2,909,755 issued on October 20, 1959, to Anton Jackson and Boris Jackson and more particularly to those receiving mating receptacles described in an article entitled "Connectors for Flat-Conductor Flexible Cables" which was written by Wilhelm Angele and published on pages 164-168 of the September 1960, issue of Electrical Manufacturing. The electrical contact surfaces 22 and 23 of the insert connector 11 are the outermost surfaces of the raised offset portions 19 and lowered offset portions 21, respectively, of the flat conductors 18 of the cable 14. As shown, the rear ridge portion 17 of the T-shaped body 12 encircles and confines the cable adjacent the side 30 of the offset portions 19 and 21 furthest from the terminus 24 of the cable 14, and the insert portion 16 confines the cable 14 between the ridge portion 17 and terminus 24 whereby the electrical contact surfaces 22 and 23 are adjacent or flush as shown with the upper surfaces 33 and lower surface 34, respectively, of the insert portion 16. It is preferred that the electrical contact surfaces 22 and 23 be slightly below their respective body surfaces 33 and 34 to prevent the accidental shorting of the electrical circuit. By alternating the raised offset portions 19 and lowered offset portions 21 between adjacent conductors any current leakage between the electrical contact surfaces 22 or 23 is held to a minimum. The ridge portion 17 of the connector 11 serves as a stop which limits the extent of insertion of the insert portion 16 into a receiving mating receptacle (not shown) and also serves as a means by which the connector 11 may be manually gripped. However, environmental conditions may dictate that ridge portion 17 be located as to define an L-shaped body for the connector 11 or be modified so as to become undiscernible from the insert portion 16. For high reliability, it is important that the outermost surfaces 22 and 23 of the conductors 18 act as the electrical contact surfaces for connector 11. To prevent corrosion of the surfaces 22 and 23 they may be gold plated.

The novel method of constructing the insert connector 11 whereby it is integrally a part of the terminal or terminus portion 13 of the flat electrical cable 14 results in a sturdy construction particularly suitable to take the rough handling of field testing and maintenance of the electrical circuitry. The method consists of taking the typical flat electrical cable 14 and

3

removing the dielectric material 15 from an area 26, which is adjacent to and spaced from the terminus 24 of the electrical cable, to bare the electrical conductors 18 for a limited extent. The remaining end portion 25 between area 26 and the terminus 24 of the dielectric material 15 serves to keep the electrical conductors 18 aligned. Following the removal of sheet dielectric material 15 from area 26, each bare electrical conductor 18 is deformed perpendicularly outward from the longitudinal axis and plane of the cable 14 in an alternating manner to form raised offset portions 19 and lowered offset portions 21 which are transversely aligned to the longitudinal axis of the cable 14. The raised offset portions 19 and lowered offset portions 21 thus define the limits of a passageway which extends transversely to the longitudinal axis of cable 14. A preformed dielectric spacer strip 27 is then inserted into the passageway formed by offset portions 19 and 21, and the terminal portion 13 of the cable 14 is then inserted into a suitable mold (not shown) by which T-shaped body 12 is integrally molded thereon. The spacer strip 27 is an important part of the molding operation since it prevents collapse of the offset portions 19 and 21.

As shown in FIGURE 3, the T-shaped body 12 overlaps a portion 28 of the cable 14 whereby additional reinforcement is provided the finished connector 11 and the conductors 18 will have less tendency to shear at the rear edge 35 of the ridge portion 17. Also, the remaining end portion 25 of the dielectric material 15 which is confined and embedded by the male insert portion 16 serves to reinforce the insert portion 16. However, it may be advantageous in some instances to place the T-shaped body 12 within area 26 whereby the portion 28 of the cable 14 is not overlapped and it is also envisioned that the remaining end portion 25 of the dielectric material 15 will not be necessary if suitable means is employed to keep the conductors 18 aligned until after the molding operation. The contact surfaces 22 and 23 may be gold plated following the removal of the dielectric plastic material 15 from area 26 or after the molding operation for the T-shaped body 12. If the conductors 18 are made of copper, the process of gold plating contact surfaces 22 and 23 may include the initial step of nickel plating.

If the connector 11 is subject to numerous connections, it should also be provided with the semi-flexible rubber reinforcement 29 which overlaps a part of electrical cable 14 and part of the rear ridge 17 as shown in FIGURES 2 and 3. The rubber reinforcement 29 is keyed into identical grooves 31 and 32 which extend the width of the ridge 17 and tapers toward the cable 14 furthest from the terminus 24. If necessary, the rubber reinforcement 29 may also be adhesively secured to the cable 14 and to the ridge 17.

A modification of the present invention wherein all the electrical contact surfaces of a connector are in the same plane is illustrated in FIGURES 4, 5, and 6. This modified male plug or terminal insert connector 41 is similar to the embodiment shown in FIGURES 1, 2 and 3 in having a T-shaped body 51 defined by a ridge portion 50 and an insert portion 54 molded on the terminal portion 40 of a flat electrical cable 45 whereby the outermost surfaces 52 of the offset portions 47 of flat conductors 46 are located adjacent to or flush with the peripheral surface 53 of the insert portion 54. In this embodiment, however, the outermost surfaces 52, which will be the electrical contact surfaces for the modified connector 41, are all located in the same plane which is flush with or adjacent to the upper surface 55 of the insert portion 54, and are staggered in a longitudinal direction to reduce any electrical current leakage.

The basic steps in constructing the embodiment shown in FIGURES 1, 2 and 3 are also used in constructing

4

the modified connector 41. The area 43 of the thin sheet of flexible dielectric plastic 42 adjacent to and spaced from the terminus 44 of the flat electrical cable 45 is first removed to bare the flat metal electrical conductors 46, and then all the bare conductors 46 within area 43 are deformed or shaped to form raised offset portions 47. As noted, all the raised offset portions 47 of the modified embodiment are deformed in the same perpendicular direction to the longitudinal axis and plane of electrical cable 45 whereby their outermost surfaces 52 which serve as electrical contacts will be located substantially in the same longitudinal plane. Also, the raised portions 47 are formed in a staggered manner in the longitudinal direction to reduce any electrical current leakage whereby two distinct rows of offset portions 47 are created which are aligned transversely to the longitudinal axis of electrical cable 45. Each row of raised portions 47 which includes the undisturbed flat portion 56 of the conductors 46 thus define the limits of a passageway. Therefore, to prevent collapse of the raised offset portions 47 during the subsequent molding operation for the T-shaped body 51, it is necessary to insert two dielectric plastic spacer strips 48 and 49 into the two spaced passageways defined by the offset portions 47 and undisturbed flat portions 56, whereby each passageway has a spacer strip.

Still another modification of the present invention wherein all the electrical contact surfaces of a connector are located in spaced recesses or windows is shown in FIGURES 7 and 8. This modified male plug or terminal insert connector 71 is also similar to the other described embodiments in having a T-shaped body 75 defined by a ridge portion 72 and an insert portion 73 integrally molded on the terminal portion 74 of a flat electrical cable 76. However, in this embodiment the electrical contact surfaces 77 of the insert portion 73 are the bare longitudinal surface of flat conductors 79 at the bottom of spaced windows or recesses 78 of the insert portion 73. The recesses 78 may be transversely aligned as shown in FIGURE 8 or staggered so as to expose the electrical contact surfaces 77 in a manner similar to that of the described embodiment shown in FIGURES 4, 5 and 6.

The steps in constructing the modified terminal insert connector 71 consists in removing the dielectric plastic material 82 from an area 81 adjacent to and spaced from the terminus 83 of a flat electrical cable 76 to bare the flat metal conductors 79, fitting a spacer strip 86 within the area 81 to support the bared conductors 79, and then molding the T-shaped body 75 about the terminal portion 74 of electrical cable 76 whereby spaced recesses 78 are formed above each conductor 79 and the upper surface 77 of each conductor 79 within area 81 is bare. The spacer strip 86 is provided with spaced grooves 87 for receiving the spaced bare conductors 79 for the purpose of keeping them aligned during the molding operation. If the recesses 78 are to be staggered as hereinbefore mentioned, it will be necessary to repeat the operation of removing the dielectric material 82 from another area, not shown, or to enlarge area 81 whereby another spacer strip, not shown, could support the conductors to be located at the bottom of the recesses staggered from recesses 78 during the molding operation for T-shaped body 72.

As shown in this embodiment, the cable 76 adjacent the terminus 83 may curve slightly within the insert portion during the molding operation but this will help to stiffen the finished insert portion 73.

It is apparent that the semi-flexible rubber reinforcement 29 of the connector 11 may readily be applied to the other modified embodiments and that all bare electrical contact surfaces of the modified embodiments may be gold plated similarly to the electrical contact surfaces 22 and 23.

Further, while the specific embodiments herein disclosed utilized flat conductors and flat electrical cables for purposes of illustration, it is to be understood that the invention is not so limited because other shapes can obviously be used in carrying out the inventive concept for the disclosed improved terminal insert connector. Also, the electrical conductors and thus the electrical contact surfaces of the improved terminal insert connector may vary in width, thickness, spacing, number, and material according to the electrical characteristics of the particular circuit designed.

Obviously, many other modifications and variations of the present invention are possible in the light of the above teachings. It is, therefore, to be understood that within the scope of the appended claims the invention may be practiced other than as specifically described.

What is claimed is:

1. A method of making an electrical insert connector on a terminus portion of a flat electrical cable having a plurality of parallel spaced electrical conductors extending along a longitudinal plane and a thin sheet of flexible dielectric material embedding said conductors, comprising: removing a portion of said dielectric material from an area adjacent to and spaced from the terminus to bare said conductors for a limited extent; and molding a T-shaped body of dielectric material which consists of a ridge portion and an insert portion on said cable about said terminus whereby said ridge portion encircles said cable adjacent said bare surfaces and said bare surfaces lie between said ridge portion and said terminus, and said insert portion confines said cable from said ridge portion and whereby said bare surfaces are left exposed and are electrical contact surfaces for said insert portion.

2. A method of making an electrical insert connector on a terminus portion of a flat electrical cable having a plurality of parallel spaced electrical conductors extending along a longitudinal axis and a thin sheet of flexible dielectric material embedding said conductors, comprising: removing a portion of said dielectric material from an area adjacent to and spaced from the terminus to bare said conductors for a limited extent, fitting a spacer strip which has a plurality of grooves within said area whereby each groove receives one side of one of said bare conductors, and molding a T-shaped body of dielectric material which consists of a ridge portion and an insert portion on said cable about said terminus, said strip and said area whereby said ridge portion encircles said cable adjacent said spacer strip and said spacer strip lies between said ridge portion and said terminus, and said insert portion confines said cable and spacer strip, whereby the side of said bare conductors opposite said spacer strip are located at the bottom of separate and distinct recesses and are left exposed to act as electrical contact surfaces for said insert portion.

3. A method of making an electrical insert connector on a terminus portion of an electrical cable having a plurality of spaced electrical conductors extending along a longitudinal axis and a dielectric sheet material embedding said conductors, comprising: removing a portion of said sheet material from an area adjacent to and spaced from the terminus to bare said conductors for a limited extent; deforming each said bare conductor outwardly from said longitudinal axis to form an offset portion, each said offset portion being deformed in an outwardly direction opposite to the outwardly direction of the offset portion of an adjacent conductor, said offset portions being aligned transversely to said longitudinal axis; inserting a cooperating preformed spacer strip of dielectric material between said aligned offset portions of adjacent conductors; and molding about said cable terminus, spacer and offset portions a connector body having an insert portion whereby the outermost surfaces of said offset portions are exposed at surfaces of said insert portion and are electrical contact surfaces for said insert portion.

4. A method of making an electrical insert connector on a terminus portion of an electrical cable having a plurality of parallel spaced electrical conductors extending along a longitudinal axis and a dielectric sheet material embedding said conductors, comprising: removing a portion of said sheet material from an area adjacent to and spaced from the terminus to bare said conductors for a limited extent; deforming each said bare conductor to form an offset portion within said area, said offset portion of each bare conductor being longitudinally staggered in relation to an offset portion of an adjacent bare conductor whereby two distinct rows of spaced offset portions are formed which are transversely aligned to said longitudinal axis and each said row defines a passageway formed by said offset portion of one bare conductor and an undisturbed portion of an adjacent bare conductor; inserting a cooperating preformed spacer strip of dielectric material within one of said passageways, inserting a second cooperating preformed spacer strip of dielectric material within the other of said passageways; and providing about the terminus portion of said cable a dielectric material connector body having an insert portion whereby the outermost surfaces of said offset portions are adjacent a surface of said insert portion and are electrical contact surfaces for said insert portion.

5. A method of making an electrical insert connector on a terminus portion of an electrical cable having a plurality of spaced electrical conductors extending along a longitudinal axis and a dielectric sheet material embedding said conductors, comprising: removing a portion of said sheet material from an area adjacent to and spaced from the terminus to bare said conductors for a limited extent; deforming each said bare conductor to form an offset portion within said area, said offset portion of each bare conductor being longitudinally staggered in relation to an offset portion of an adjacent bare conductor whereby two distinct rows of spaced offset portions are formed which are transversely aligned to said longitudinal axis and each said row defines a passageway formed by said offset portion of one bare conductor and an undisturbed portion of an adjacent bare conductor; inserting a cooperating preformed spaced strip of dielectric material within one of said passageways, inserting a second cooperating preformed spacer strip of dielectric material within the other of said passageways; and molding about the terminus, said area and said strips of said cable a dielectric material connector body having an insert portion whereby the outermost surfaces of said offset portions are exposed at surfaces of said insert portion and are electrical contact surfaces for said insert portion.

6. A method of making an electrical insert connector on a terminus portion of a flat electrical cable having a plurality of parallel spaced electrical conductors extending along a longitudinal axis and a thin sheet of flexible dielectric material embedding said conductors, comprising: removing a portion of said dielectric material from an area adjacent to and spaced from the terminus to bare said conductors for a limited extent; deforming each said bare conductor to form an offset portion within said area, said offset portion of each bare conductor being longitudinally staggered in relation to an offset portion of an adjacent bare conductor whereby two distinct rows of spaced offset portions are formed which are transversely aligned to said longitudinal axis and each said row defines a passageway formed by said offset portion of one bare conductor and an undisturbed portion of an adjacent bare conductor; inserting a cooperating preformed strip of dielectric material within one of said passageways; inserting a second cooperating preformed strip of dielectric material within the other of said passageways; and molding a T-shaped body of dielectric material which consists of a ridge portion and an insert portion on said cable about said terminus, said strips and said area whereby said ridge portion encircles said cable and said offset

portions lie between said ridge portion and said terminus, and said insert portion confines said cable from said ridge portion and whereby the outermost surfaces of said offset portions are exposed at the surfaces of said insert portion and are electrical contact surfaces for said insert portion.

7. A method as defined by claim 8 including a step of joining a tapering semi-flexible reinforcement to said ridge portion and said cable whereby said semi-flexible reinforcement tapers in a direction opposite from that of said insert portion.

8. A method of making an electrical insert connector on a terminus portion of a flat electrical cable having a plurality of parallel spaced electrical conductors extending along a longitudinal axis and a thin sheet of flexible dielectric material embedding said conductors, comprising: removing a portion of said dielectric material from an area adjacent to and spaced from the terminus to bare said conductors for a limited extent; deforming each said bare conductor outwardly from said longitudinal axis to form an offset portion within said area, said offset portion of each bare conductor being deformed in an outwardly direction opposite to the outwardly direction of the offset portion of an adjacent bare conductor, said offset portions being aligned transversely to said longitudinal axis; inserting a cooperating performed spacer

strip of dielectric material between said aligned offset portions of adjacent bare conductors; and molding a T-shaped body of dielectric material which consists of a ridge portion and an insert portion of said cable about said terminus and said area whereby said ridge portion encircles said cable adjacent said offset portions and said offset portions lie between said ridge portion and said terminus, and said insert portion confines said cable from said ridge portion and whereby the outermost surfaces of said offset portions are exposed at the surface of said insert portion and are electrical contact surfaces for said insert portion.

References Cited by the Examiner

UNITED STATES PATENTS

1,287,101	12/1918	Reynolds	29—155.55
2,063,641	12/1936	Van Billiard	339—218
2,683,287	7/1954	Cochran et al.	29—155.55 XR
2,994,059	7/1961	Dahlfren et al.	174—117 XR
3,004,237	11/1961	Cole et al.	339—176
3,015,877	1/1962	Francis	339—218 XR
3,017,602	1/1962	Little	339—17

JOHN F. CAMPBELL, *Primary Examiner.*

R. W. CHURCH, *Examiner.*