

July 26, 1966

P. D. READER ET AL.

3,262,262

ELECTROSTATIC ION ROCKET ENGINE

Filed Jan. 18, 1965

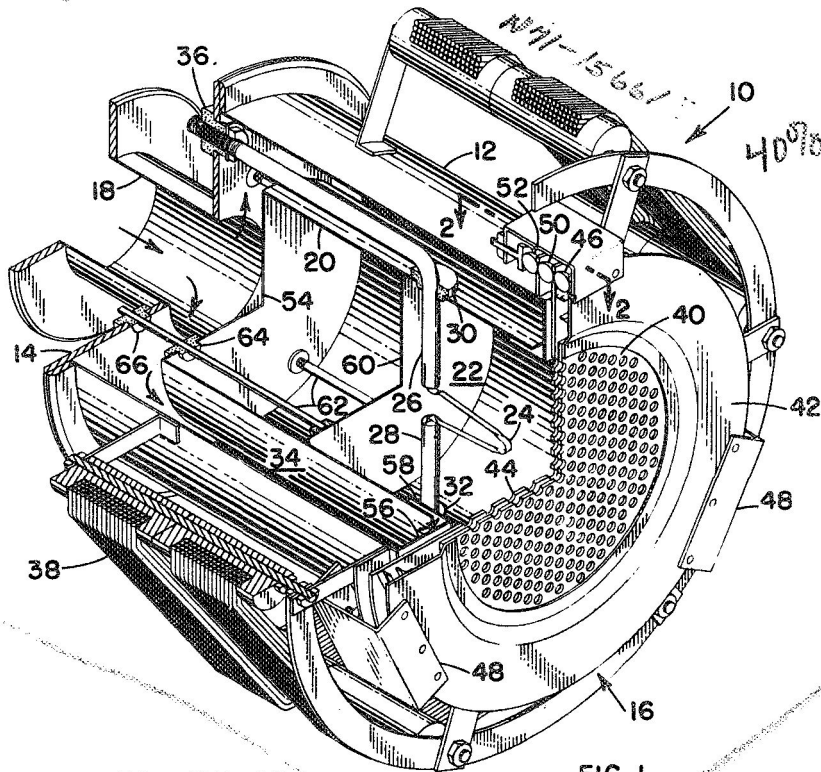

FIG. 1

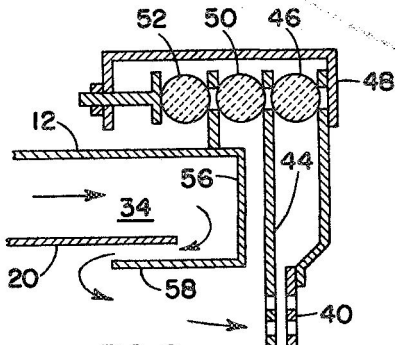

FIG. 2

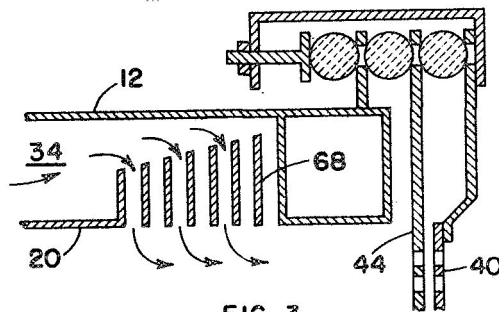

FIG. 3

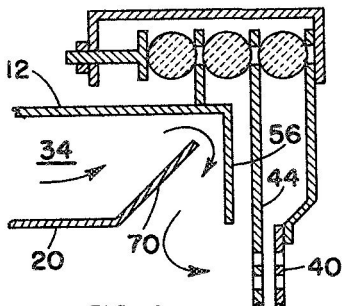

FIG. 4

INVENTORS  
PAUL D. READER  
HAROLD R. KAUFMAN

BY

*Gene E. Coy*  
*Gene E. Shook*  
ATTORNEYS

917

1

3,262,262

## ELECTROSTATIC ION ROCKET ENGINE

Paul D. Reader, North Olmsted, and Harold R. Kaufman,  
Berea, Ohio, assignors to the United States of America  
as represented by the Administrator of the National  
Aeronautics and Space Administration

Filed Jan. 18, 1965, Ser. No. 426,455

9 Claims. (Cl. 60—35.5)

The invention described herein may be manufactured and used by or for the Government of the United States of America for governmental purposes without the payment of any royalties thereon or therefor.

This invention is concerned with electrostatic ion rocket engines and, more particularly, with an electron bombardment ion rocket engine having an improved propellant introduction system.

An electron bombardment ion rocket engine of the type shown in Patent No. 3,156,090, has a through-feed propellant supply system wherein a vaporized propellant is fed to a flow distributor prior to entering an ion chamber where it is ionized by high velocity electrons emitted by a cathode. The ionized propellant is accelerated by a positive screen and negative accelerator grid located at the downstream end of the engine. It has been found that a major portion of the total ion beam of such an electron bombardment ion rocket engine is located in a central area near the axis of the engine because of the position of the cathode and the resulting radial distribution of high velocity ionizing electrons. This causes non-uniform erosion of the accelerator grid which decreases the useful life of the engine.

This non-uniform erosion problem has been solved by the present invention without relying on a plurality of cathodes whose use is mechanically and electrically complex. In the electrostatic ion rocket engine constructed in accordance with this invention, propellant vapor is introduced into the ion chamber about its periphery adjacent the accelerator system which results in lower discharge power losses and produces a uniform ion-current profile across the grids which increases the useful life of the engine. This uniform current profile enables the current density as well as the thrust density to increase significantly for a given accelerator lifetime. This is achieved by matching the propellant distribution and the ionizing electron distribution to more closely approximate a uniform ion production rate at the plane of the accelerator system.

It is, therefore, an object of the present invention to provide an electrostatic ion rocket engine having an improved propellant introduction system for feeding an ionizable propellant into the ion chamber.

Another object of the invention is to provide an improved electron bombardment ion rocket engine wherein the propellant distribution is matched with the ionizing electron distribution for a more uniform ion production rate adjacent the accelerator system.

A further object of the invention is to provide an electrostatic ion rocket engine in which the propellant is introduced into the ion chamber about the periphery of the accelerator system to produce a uniform ion current profile across the grid.

Other objects of the invention will be apparent from the following detailed description taken with the drawings in which like numerals are used throughout to identify like parts.

In the drawings:

FIG. 1 is an axial quarter section of an electron bombardment ion engine shown in perspective utilizing an improved propellant introduction system constructed in accordance with the invention;

FIG. 2 is an enlarged sectional view taken along the

2

line 2—2 in FIG. 1 illustrating the reverse feed feature of this embodiment;

FIG. 3 is an enlarged sectional view of an alternate embodiment of the invention having a cross feed feature; and

FIG. 4 is an enlarged sectional view of another alternate embodiment of the invention having an angle feed feature.

Referring now to the drawings there is shown in FIG. 1 an improved electron bombardment ion rocket engine 10 constructed in accordance with the present invention. This rocket engine includes a cylindrical casing 12 that is closed at the forward end by a centrally apertured end plate 14. An accelerator system 16, whose operation will be described later in greater detail, is mounted at the opposite end of the casing 12.

A propellant supply conduit 18 is located at the forward end of the rocket 10 and forms a source of ionizable propellant. One end of the conduit 18 is in communication with the interior of the casing 12 through the central aperture in the end plate 14 while the opposite end is connected to a container of propellant (now shown), such as mercury. The propellant container may be a steam jacketed boiler of the type shown in Patent No. 3,156,090 having a calibrated orifice at the entrance to the supply conduit 18.

A tubular anode 20 is mounted in the casing 12 and forms the peripheral wall of a chamber 22 for containing the ionizable propellant supplied from the source 18. A thermionic emitting cathode 24, such as a tantalum or tungsten filament, is supported in the center of the chamber 22 by a pair of electrically conducting support arms 26 and 28 which are maintained out of electrical contact with the anode 20 by insulators 30 and 32, respectively. Those portions of the arms 26 and 28 within the chamber 22 between the cathode 24 and the insulators 30 and 32 are generally normal to the axis of the ion rocket engine 10. The arms 26 and 28 are curved at the insulators 30 and 32, and the sections outside the chamber 22 extend toward the front of the engine 10 in an annular passage 34 formed by the space between the anode 20 and the casing 12. The forward end of the arm 26 extends through an insulator 36 in the end plate 14 while the other arm 28 extends through a similar insulator, and both arms 26 and 28 are connected to suitable power supply, such as shown in Patent No. 3,156,090.

The particle densities of the plasma in the chamber 22 are sufficiently small that the mean free path for ionization is quite long thereby necessitating the containment of the high velocity ionizing electrons within this chamber. An axial magnetic field is utilized to lengthen the path of the high velocity electrons that are emitted from the cathode 24 to increase the probability of electron-propellant collisions. This magnetic field is provided by an electromagnet 38 which surrounds the casing 12. If desired, a plurality of permanent magnets of the type shown in application Serial No. 312,269, now U.S. Patent No. 3,238,715, may be utilized instead of the electromagnet 38.

The accelerating system 16 includes a grid 40 in the form of an apertured plate which is positioned at the downstream or exhaust end of the chamber 22 to accelerate the ions in the plasma that move to this end of the engine 10. The grid 40 is secured to and is in electrical contact with an annulus plate 42. A screen 44 containing a plurality of apertures is positioned between the chamber 22 and the grid 40. The apertures in the screen 44 are aligned with the apertures in the grid 40 to reduce the impingement of the ions on the grid.

The grid 40 is spaced from the screen 44 by sapphire insulating balls 46 carried by brackets 48 mounted on

the annulus plate 42. Similar insulating balls 50 and 52 insulate the brackets 48 from the casing 12. The grid 40 and the screen 44 are preferably matched-drilled molybdenum plates while the remaining structure of the engine 10 is fabricated of nonmagnetic stainless steel with the exception of the cathode, insulators and electromagnet.

The anode 20, cathode 24, grid 38, and screen 44 are connected to suitable sources of power in the manner shown in the aforementioned Patent No. 3,156,090. The screen 44 is maintained at a voltage potential substantially equal to that of a cathode 24 while the grid 40 has a relatively high negative potential relative to the screen. The thrust producing mechanism of the engine 10 is the momentum change of the ions as they are accelerated by the electrostatic field which is applied between the screen 44 and the grid 40.

According to the present invention, propellant from the source 18 is introduced into the chamber 22 adjacent the screen 42 to provide a uniform current profile across the grid 40 which increases the useful life of the engine 10. This is achieved by matching the propellant distribution and the ionizing electron distribution to more closely approximate a uniform ion production rate at the plane of the accelerator system 16 which results in a relatively uniform erosion of the grid 40.

In the embodiment shown in FIGS. 1 and 2 having a reverse feed feature propellant from the source 18 enters the casing 12 through the end plate 14 and passes around a circular plate 54 mounted on the forward end of the anode 20. Thereupon the gaseous propellant passes through the annular space 34 between the outer surface of the anode 20 and the inner surface of the casing 12 toward the rear of the engine 10. Rearward flow of the propellant in the annular space 34 is limited by an inwardly directed circular lip 56 at the rear end of the casing 12 adjacent the screen 44. As the propellant moves inwardly toward the chamber 22 through a slot formed between the rear end of the anode 20 and the lip 56, it contacts a tubular member 58 in the form of a cylindrical wall mounted at the rear of the anode 20 on the inner edge of the lip 56. The tubular member 58 has an outside diameter smaller than the inside diameter of the tubular anode 20 and this cylindrical wall extends into the anode to direct the propellant away from the screen 42 toward an impervious wall 60 which forms the forward end of the chamber 22 as shown in FIG. 1. The periphery of the wall 60 is insulated from the anode 20. The wall 60 is mounted on a plurality of electrically conducting rods 62 which extend through insulators 64 and 66 in the circular plate 54 and the end plate 14 respectively. The rods 62 are connected to a suitable electrical power source, and the wall 60 is biased to the same potential as the cathode 24 and screen 44. Axial movement of the wall 60 to alter the volume of the chamber 22 is accomplished by moving the rods 60 in the insulators 64 and 66. The circular plate 54 may be utilized to perform the function of the wall 60 once its optimum location for a particular engine has been determined.

In the embodiment shown in FIG. 3 having a cross-feed feature, a plurality of annular plates 68 are mounted in the annular passage 34 adjacent the screen 44. The plates 68 are spaced from one another and are parallel to the screen 44 with their flat faces extending perpendicular to the longitudinal axis of the engine 10 to direct the propellant into the chamber 22 through openings in the anode 20 along paths perpendicular to the axis. The outside diameter of each plate 68 is greater than that of the adjacent upstream plate and smaller than that of the adjacent downstream plate while the inside diameters of the plates 68 are the same as the inside diameter of the anode 20.

In the embodiment shown in FIG. 4 having an angle-feed feature, an outwardly directed flange 70 is provided on the rear end of the anode 20 adjacent the screen 44.

The flange 70 is angularly disposed with respect to the anode 20 and the screen 44 and extends into the annular passage 34 to direct the propellant through a peripheral slot in the anode 20 along paths that are angularly disposed with respect to both the longitudinal axis of the chamber 22 and the screen 44.

While several embodiments of the improved propellant introduction system have been described, it is apparent that various structural modifications may be made to these systems without departing from the spirit of the invention or the scope of the subjoined claims.

We claim:

1. An electrostatic ion rocket engine comprising
  - a source of ionizable propellant,
  - a chamber for containing said propellant,
  - an anode,
  - a thermionic emitting cathode within said chamber having a negative potential relative to said anode for bombarding said propellant with high velocity electrons to form ions,
  - a screen adjacent said chamber having a voltage potential substantially equal to that of said cathode,
  - an apertured grid spaced from said screen away from said chamber and having a relatively high negative potential relative to said screen to accelerate said ions away from said engine, said screen being in substantial alignment with said grid for shielding the same from the ions to reduce erosion,
  - magnetic means positioned around said casing to form a magnetic field about said propellant and said cathode whereby the paths of said high velocity electrons are lengthened to increase the rate of collision of said electrons with particles of said propellant, and
  - means for introducing said propellant from said source into said chamber adjacent said screen whereby said erosion is relatively uniform across said grid.
2. An electrostatic ion rocket engine comprising
  - an anode forming a peripheral wall of a chamber for containing an ionizable propellant,
  - a thermionic emitting cathode within said chamber having a negative potential relative to said anode for bombarding said propellant with high velocity electrons to form ions,
  - a screen at one end of said chamber having a voltage potential substantially equal to that of said cathode,
  - an apertured grid spaced from said screen away from said chamber and having a relatively high negative potential relative to said screen to accelerate said ions away from said engine, said screen being in substantial alignment with said grid for shielding the same from said ions to reduce erosion, and
  - means for introducing said propellant into said chamber adjacent said one end thereof to provide a uniform current profile across said grid.
3. An electrostatic ion rocket engine comprising
  - a casing,
  - a tubular anode within said casing forming a peripheral wall of a chamber for containing an ionizable propellant,
  - a thermionic emitting cathode within said anode for bombarding said propellant with high velocity electrons to form ions,
  - a screen at one end of said chamber having a voltage potential substantially equal to said cathode,
  - an apertured grid having a relatively high negative potential relative to said cathode positioned on the opposite side of said screen from said anode and spaced therefrom to accelerate said ions away from said engine, said screen being in substantial alignment with said grid for shielding the same from said ions to reduce erosion, and
  - means for introducing said propellant into said chamber at said one end thereof about the periphery of said anode to provide a uniform current profile across said

screen and grid so that said erosion is relatively uniform across said grid.

- 4. An electrostatic ion rocket engine as claimed in claim 3, wherein the tubular anode is spaced from the inner wall of the casing, a source of ionizable propellant in communication with the space between said anode and said casing, said space being in communication with said chamber at the one end thereof adjacent the screen. 5
- 5. An electrostatic ion rocket engine as claimed in claim 4, including a plurality of annular plates mounted in the casing at the end thereof adjacent the screen, said plates being spaced from one another with their flat faces extending substantially perpendicular to the longitudinal axis of said chamber and parallel to the screen for directing the propellant into said chamber along paths generally perpendicular to said axis. 10
- 6. An electrostatic ion rocket engine as claimed in claim 4, including a tubular member having a diameter smaller than that of the tubular anode mounted at the end thereof adjacent the screen, said tubular member extending into said tubular anode and being spaced inwardly therefrom to direct the propellant along the inner surface of the tubular anode away from said screen. 15
- 7. An electrostatic ion rocket engine as claimed in claim 4, including an outwardly directed flange on the end of the tubular anode adjacent the screen, said flange being angularly 20

- disposed with respect to said tubular anode and said screen for directing the propellant along paths that are angularly disposed with respect to the longitudinal axis of the chamber.
- 8. An electrostatic ion rocket engine comprising a chamber for containing an ionizable propellant, means for introducing said propellant into said chamber about the periphery thereof adjacent one end, means within said chamber for bombarding said propellant with high velocity electrons to form ions, means positioned at said one end of said chamber adjacent said propellant supply means to accelerate said ions away from said engine.
- 9. In an electrostatic ion rocket engine of the type having a chamber for containing an ionizable propellant and a grid for accelerating ions away from the engine, the improvement comprising an impervious wall at one end of the chamber remote from the grid, and means for introducing the ionizable propellant into the chamber about the periphery thereof at the end opposite said wall. 25

References Cited by the Examiner

UNITED STATES PATENTS

3,075,115	1/1963	Flowers et al. -----	313—63
3,156,090	11/1964	Kaufman -----	60—35.5

MARK NEWMAN, *Primary Examiner.*  
 C. R. CROYLE, *Assistant Examiner.*