

December 1971

Brief 71-10530

NASA TECH BRIEF

Marshall Space Flight Center



NASA Tech Briefs announce new technology derived from the U.S. space program. They are issued to encourage commercial application. Tech Briefs are available on a subscription basis from the National Technical Information Service, Springfield, Virginia 22151. Requests for individual copies or questions relating to the Tech Brief program may be directed to the Technology Utilization Office, NASA, Code KT, Washington, D.C. 20546.

Brushless DC Motor with Dual Windings

A novel, split-winding dc motor has both high starting torque and high running speeds. The motor's dual windings may be connected in series to produce high torque at low speeds (520 rpm with 6.70 ft-lbs torque), or in parallel to give low torque at high speeds (1040 rpm with 3.35 ft-lbs torque).

leads the rotor field by 90°. The motor torque, which tends to align the two fields, remains the same regardless of rotor position. Thus, the control system replaces the commutator in a conventional dc motor.

The figure shows a block diagram of the motor and control system. The dc-dc converter, connected to a

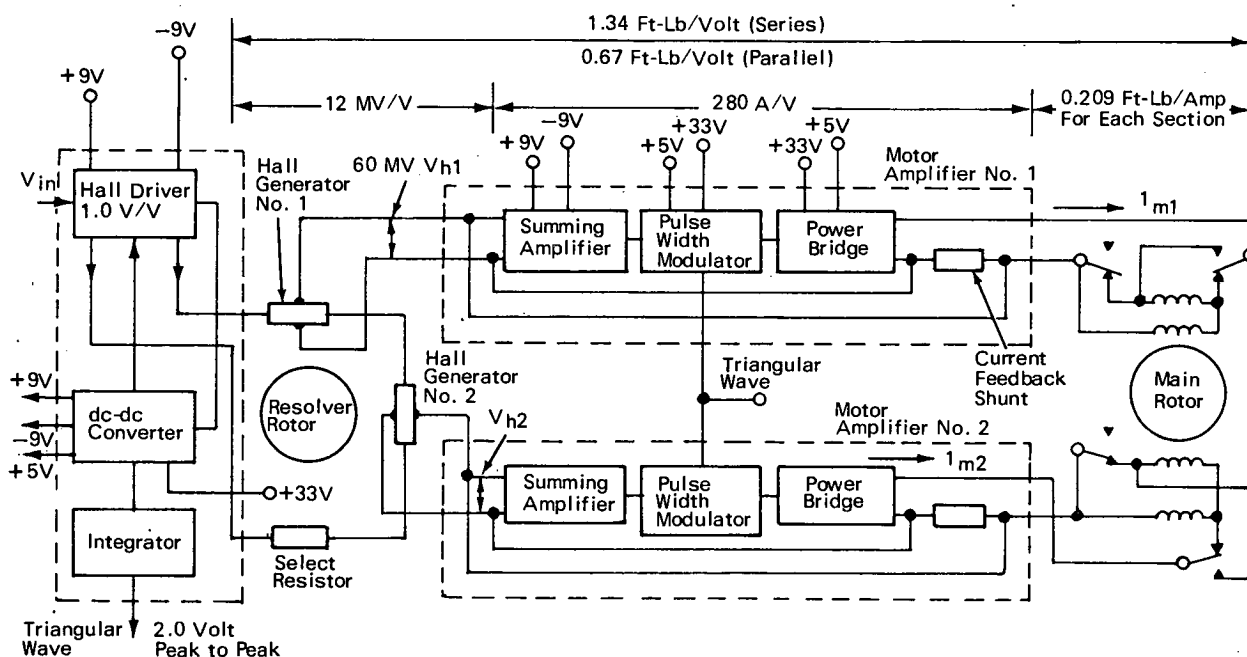

The motor control system consists of a Hall-effect generator/resolver and associated electronic amplifiers and switches. The system controls the power supplied to the motor's stator windings, causing the stator to produce a magnetic field that varies with the position of the resolver rotor. The resolver rotor is mechanically coupled to the main permanent-magnet rotor, and is aligned so that the stator field constantly

+33 Vdc external power supply, generates the low voltage supplies required for operating integrated circuits. It also produces a 5 kHz square wave, which is integrated to provide a triangular waveform for the pulse width modulator.

The motor amplifiers increase the Hall voltages, V_{h1} and V_{h2} , to drive the two motor windings with currents I_{m1} and I_{m2} . The motor currents are pro-

(continued overleaf)

portional to the sine and cosine of the motor shaft angle. Each motor amplifier consists of a power bridge circuit, a pulse width modulator, a summing amplifier and shunts. The pulse width modulator converts dc to 10 kHz pulse trains which are fed to two drivers. The drivers, high voltage gates, operate the transistor switches of the power bridge. Shunts in the bridge circuit develop a feedback voltage which is proportional to motor current.

Note:

The following documentation may be obtained from

National Technical Information Service
Springfield, Virginia 22151
Single document price \$3.00
(or microfiche \$0.95)

Reference:

NASA CR-102675 (N70-28243), Final Report,
Brushless DC Motor and Controller

Patent status:

No patent action is contemplated by NASA.

Source: E. W. Manteuffel, G. F. Auclair, and
B. H. Hertzendorf of
General Electric Co.
under contract to
Marshall Space Flight Center
(MFS-21290)