

# NASA TECH BRIEF

## NASA Pasadena Office



NASA Tech Briefs announce new technology derived from the U.S. space program. They are issued to encourage commercial application. Tech Briefs are available on a subscription basis from the National Technical Information Service, Springfield, Virginia 22151. Requests for individual copies or questions relating to the Tech Brief program may be directed to the Technology Utilization Office, NASA, Code KT, Washington, D.C. 20546.

### Improved Circuit Avoids Premature Power Transistor Failure

#### The problem:

The frequent failure of expensive power transistors in power converters and inverters causes costly, inconvenient, and sometimes dangerous delays. Output transistor failures commonly occur in conven-

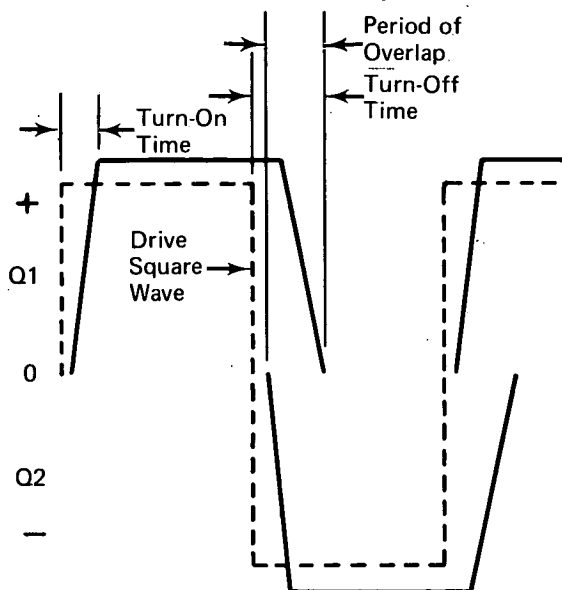

Figure 1. Idealized Drive and Output Wave Forms

tional circuits in which a pair of alternately switched transistors provides the output to the load. A short period of overlap occurs, during which both transistors are in the turned-on state. When one transistor is finally turned off, a large voltage spike appears across its collector-to-emitter circuit. This spike overstresses the transistor and can bring about premature failure.

#### The solution:

Insert a suitable reactor in the base-drive circuit of each power transistor in order to delay the

turn-on of one transistor until the other has turned off.

#### How it's done:

The simultaneous turned-on period occurs because current flow in the switched-off transistor turns off three times more slowly than it turns on in the switched-on transistor. This is shown in Figure 1, where the idealized drive square wave is shown by a broken line and the waveforms resulting from the current flows in the power transistors are shown in solid lines.

For the short period of overlap during which both transistors are turned on, current travels in both halves of the output transformer primary winding. Since the two flows are in opposite directions, the opposing magnetic fluxes cancel. The impedance of the transformer primary winding drops to a very low value, and a very large current is drawn from the power source. It is this large current that is interrupted when a switched-off transistor finally turns off. The interrupted current flow through the leakage reactance of the transformer develops an extremely high voltage approaching infinity. Measurements indicate that potentials as high as twenty times the supply voltage actually appear across the collector-emitter junction of the switched-off transistor.

Since turn-off times cannot be shortened, the period of overlap can only be eliminated by delaying turn-on of the switched-on transistor until current flow has ceased in the switched-off transistor. This can be effected by inserting a reactor in the base-drive circuit of each power transistor.

In the improved circuit (Fig. 2), the reactors L1 and L2 are each comprised of two windings on a toroidal core made of a low-iron content material

(continued overleaf)

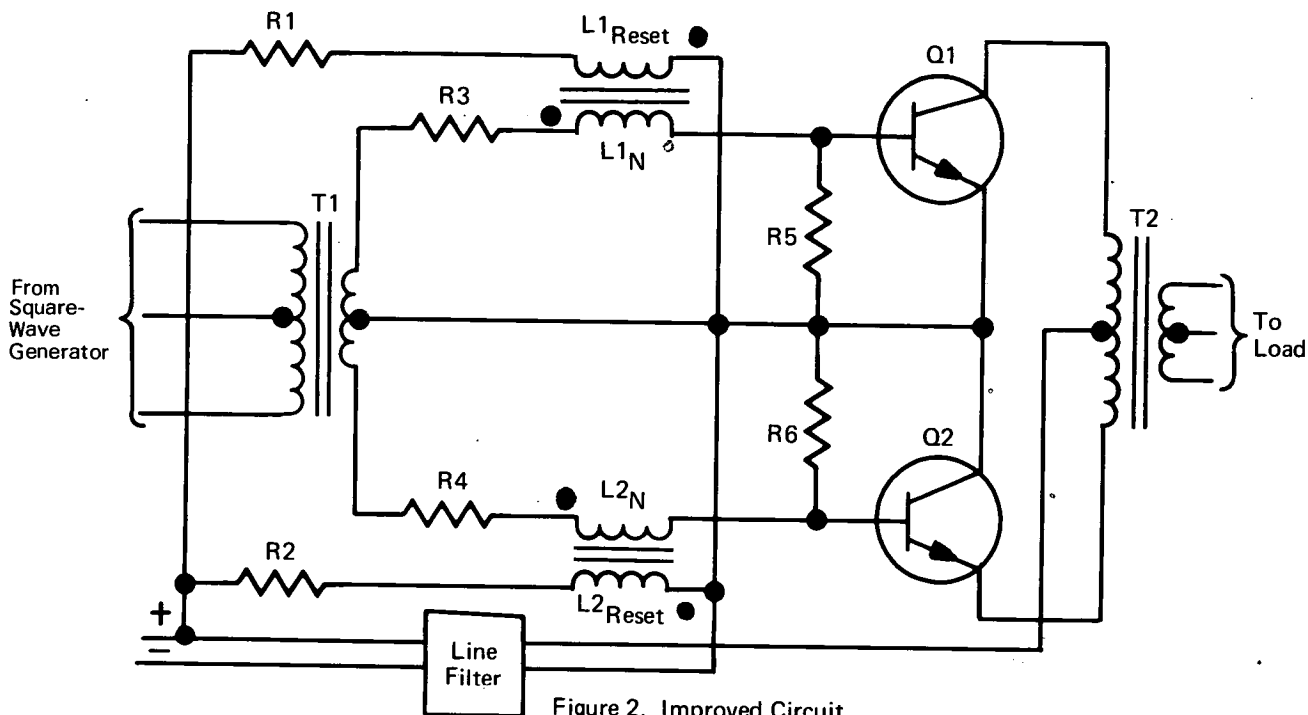

Figure 2. Improved Circuit

that can produce a steep-sided hysteresis loop. Winding  $L1_N$ , for example, is in series with the base-drive of transistor  $Q1$ , and winding  $L1_{Reset}$  is a bias winding used to reset the core. The bias windings are supplied with a constant dc excitation from the power source, with resistors  $R1$  and  $R2$  limiting the current through the bias windings. The cores are thus magnetized toward saturation.

When the square wave appears across the secondary winding of transformer  $T1$ , the positive-going leading edge tends to drive the base of transistor  $Q1$  into conduction. The current flow produces flux through winding  $L1_N$  but in a direction that produces flux in opposition to the existing core magnetization. The interaction tends to desaturate the existing core magnetization, and to drive core magnetization toward saturation in the opposite direction. Energy is absorbed from the leading portion of the square wave when the core saturation produced by current flow in the bias winding is counteracted. Drive voltage to the base of the transistor is delayed during this period, and this delays current flow turn-on until the other transistor has turned off. On the opposite half cycle, the bias winding then drives core magnetization in the "reset" direction.

Before the turn-on of transistors  $Q1$  and  $Q2$ , there is no current path to provide magnetizing current to windings  $L1_N$  and  $L2_N$ . Resistors  $R5$  and  $R6$  are therefore provided to enable the flow of magnetizing current through the windings when the square wave pulse appears. The value of these resistors is selected to prevent premature turn-

on. Because of core design, it is possible to use several turns for the windings. Accordingly, the required magnetizing currents can be very small, the power loss in the windings will be correspondingly small, and the values of resistors  $R5$  and  $R6$  can be higher.

**Note:**

Requests for further information may be directed to:

Technology Utilization Officer  
 NASA Pasadena Office  
 4800 Oak Grove Drive  
 Pasadena, California 91103  
 Reference: TSP71-10370

**Patent status:**

This invention is owned by NASA, and a patent application has been filed. Royalty-free non-exclusive licenses for its commercial use will be granted by NASA. Inquiries concerning license rights should be made to:

Patent Counsel  
 Mail Code 1  
 NASA Pasadena Office  
 4800 Oak Grove Drive  
 Pasadena, California 91103

Source: Col. W. T. McLyman of Caltech/JPL under contract to NASA Pasadena Office (NPO-11365)