

August 1971

Brief 71-10284

NASA TECH BRIEF

Ames Research Center



NASA Tech Briefs announce new technology derived from the U.S. space program. They are issued to encourage commercial application. Tech Briefs are available on a subscription basis from the National Technical Information Service, Springfield, Virginia 22151. Requests for individual copies or questions relating to the Tech Brief program may be directed to the Technology Utilization Office, NASA, Code KT, Washington, D.C. 20546.

On-Line Analysis of Random Vibrations

A measuring apparatus, Randomdec, can be used to analyze the vibrations resulting from random excitations of systems operating in natural environments. The apparatus provides continuous

In the new device (see Fig. 1.), the random signal from a vibration transducer attached to the structure is connected to the input. A voltage reference level (1) and a clock rate (2) are set,

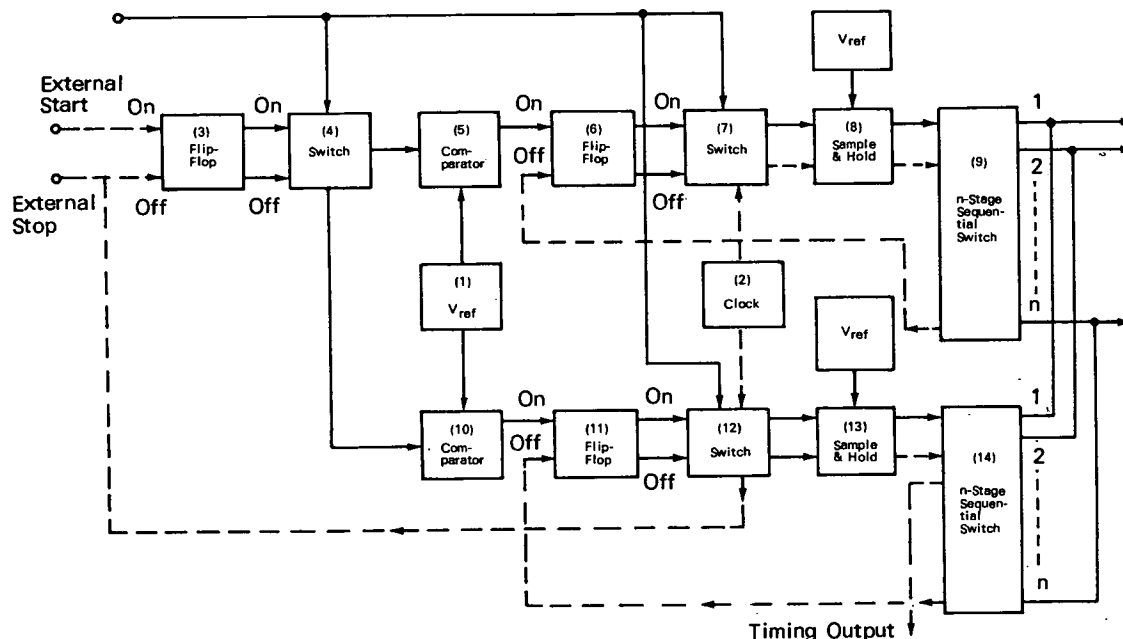

Figure 1.

on-line signatures representative of a system free-vibration curve, from which meaningful data such as damping decrement and period may be ascertained. Selected points on the curve may then be used in control and failure detection systems.

The device is applicable to both linear and nonlinear systems under nonstationary vibratory conditions. Prior art spectral analyzers and correlation computers do not, in general, give satisfactory results under these conditions.

and the external start is activated. Flip-flop (3) activates switch (4) which sends the input signal to comparators (5) and (10). When the input signal reaches the voltage reference with a positive slope (A1 in Figure 2), comparator (5) activates switch (7) and clock (2) via flip-flop (6), sending the input to the sample and hold block (8). An n-stage sequential switch (9) sequentially feeds a sample with each clock pulse into output lines 1, 2, . . . n. Similarly, comparator (10) activates blocks (11),

(continued overleaf)

(12), (13), and (14) when the input signal crosses the reference with a negative slope (B1 in Figure 2). The outputs of (14) are fed into the corresponding outputs of (9). When the nth sample is

through an analog or digital averaging circuit. The real time curve can be compared by computer with a stored standard curve. The computer can be connected to a servo that modifies the status of the

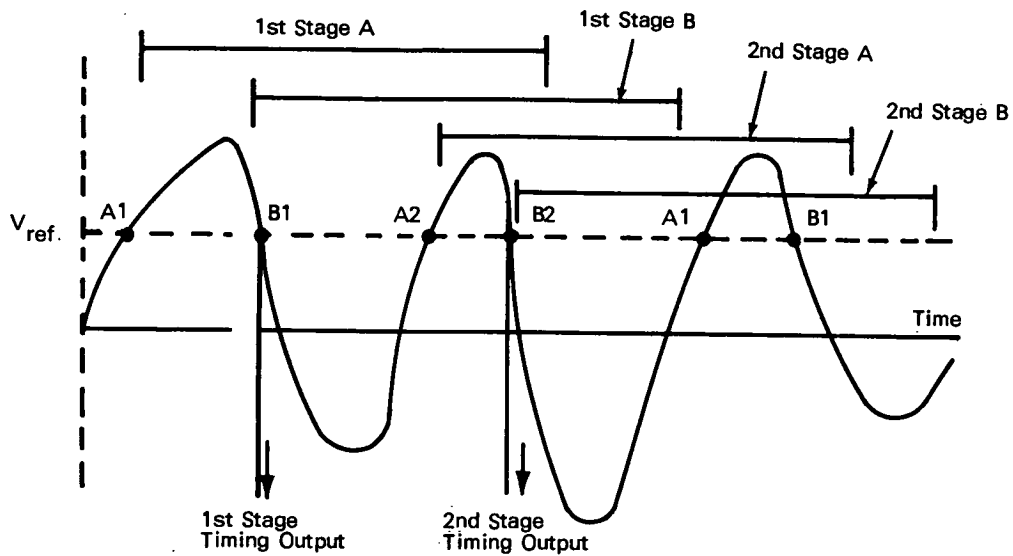

Figure 2.

taken, feedback signals from (9) and (14) turn off flip-flops (6) and (11), respectively. Also, when switch (12) is activated, a timing signal is fed back to flip-flop (3) so that the system will not operate until another start signal is received. A timing signal is also put out by block (14) shortly after B1 is reached. This signal may be fed back to the external start for single-stage operation, or fed to the second-stage Randomdec (Figure 2) for two-stage operation.

In the two-stage operation, the timing output from the first stage activates a second stage, which operates on the next peak at points A2 and B2. The timing output of the second stage feeds back to the first stage, which operates on the next peak. In this manner, all of the peaks are included in the calculations. Ordinarily, only two stages are needed to obtain the random damping decrement because the stage operation time needed is only slightly longer than one period. (In certain laboratory applications, it may be desirable to examine more than one period of the decrement. In these instances, any number of stages may be added to ensure that all peaks are included.)

The outputs of the sequential switches may be read in any of several ways. For example, they can be displayed on a CRT after being passed

vibrating system when a predetermined variance is noted. If such a system were to be installed in an aircraft, for example, the servo might control the thrust of one or more of the engines. In an aircraft, multiple transducers could be placed about the aircraft and a selector switch could enable the flight engineer or operator to sequentially monitor each transducer location.

Note:

Requests for further information may be directed to:

Technology Utilization Officer
Ames Research Center
Moffett Field, California 94035
Reference: B71-10284

Patent status:

Inquiries about obtaining domestic and foreign licenses of this invention may be made to:

Patent Counsel
Mail Code 200-11A
Ames Research Center.
Moffett Field, California 94035

Source: H. A. Cole, Jr.
Ames Research Center
(ARC-10154)