

June 1971

Brief 71-10163

NASA TECH BRIEF

Ames Research Center



NASA Tech Briefs announce new technology derived from the U.S. space program. They are issued to encourage commercial application. Tech Briefs are available on a subscription basis from the National Technical Information Service, Springfield, Virginia 22151. Requests for individual copies or questions relating to the Tech Brief program may be directed to the Technology Utilization Office, NASA, Code KT, Washington, D.C. 20546.

Miniature Implantable Instrument Measures and Transmits Heart Function Data

The problem:

Measure heart dimensions and dimension changes during the cardiac cycle in order to characterize the hydraulic and/or muscle function for an intact ventricle.

at low voltage and power in conjunction with a telemetry link at 88 to 108 MHz (FM). An actuator, which radiates an impulse at 700 kHz, is used to energize an implanted electronic switch that activates the battery (2.7 to 4.05 V) feeding cur-

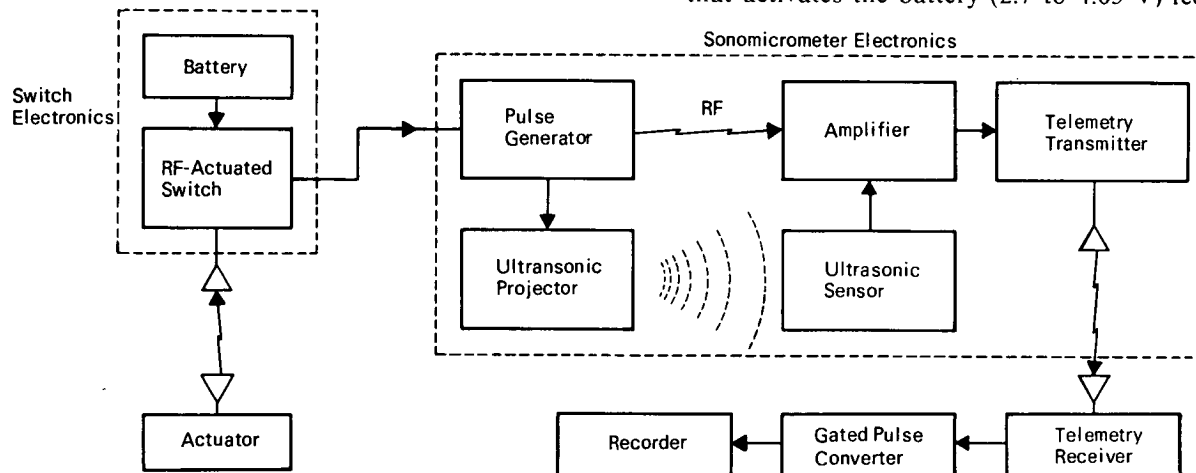

Figure 1. Block Diagram of Sonomicrometer

The solution:

The heart diameter is derived from the measured transit time of a 2.25 MHz ultrasonic pulse between two piezoelectric crystals attached to diametrically opposite surfaces of the heart. A miniature instrument implanted within the chest cavity telemeters information to an external receiver-converter. The entire system permits the continual recording of dimensional data taken from awake, undisturbed animals during long-term experiments, without the complications of externally mounted instrumentation.

How it's done:

The sonomicrometer, a miniature implantable ultrasonic system. (Figure 1), was designed to operate

rent into the circuitry of the ultrasonic measuring system and the telemetry transmitter. The pulse generator of the ultrasonic system supplies electrical pulses at a repetition rate of 450 Hz to the ultrasonic projector. The projector converts the electrical pulses to 2.25 MHz ultrasonic pulses that traverse the biomedica and impinge on the ultrasonic sensor. The sensor converts the ultrasonic pulses to electrical pulses that are subsequently amplified and used to amplitude-modulate the FM telemetry signal so that it can be transmitted to a remote telemetry receiver. Output signals from the receiver are fed to a gated pulse converter which provides an analog voltage signal suitable for recording. Heart dimensional information is obtained from the elapsed time

(continued overleaf)

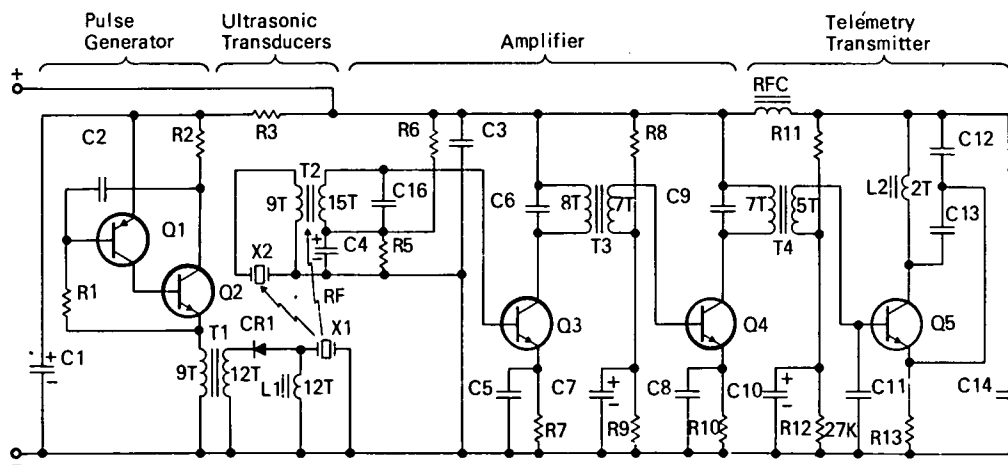

Figure 2. Circuit Diagram of Sonomicrometer

between the projector impulse and the sensor impulse, and is based on a sonic velocity of 1540 m/sec.

The repetition rate of the relaxation oscillator formed by transistors Q1 and Q2 of the pulse generator (Figure 2) is determined by the time constant of resistor R1 and capacitor C2. The energy stored in C2 is rapidly discharged through Q2 when the forward bias on the base of Q1 is exceeded; and, since the current path includes the primary winding of transformer T1, positive and negative output spikes are generated in the secondary winding. A fast diode, CR1, allows only the negative current spike to be passed into the resonant circuit formed by inductor L1 and the capacitance of the ultrasonic projector crystal X1. The results are a 2.25 MHz ultrasonic impulse, which travels through the biomedica at a slow speed, and a burst of rf power to the input winding of transformer T2. The direct-coupled, voltage impulse, which represents the ultrasonic projector burst and the impulse derived from the sensor after it has traversed the biomedica, is amplified by two tuned transformer-coupled transistor amplifier stages, Q3 and Q4, to a level sufficient to amplitude-modulate the telemetry transistor Q5. This transistor and associated components serve as the rf oscillator and telemetry transmitter. The circuit is a modified version of the Colpitts oscillator, where inductor L2 also serves as the loop transmitting antenna.

The miniature, implantable, telemetry-actuated electronic switch, developed for use with the sonomicrometer, is fully controllable by single-frequency telemetry pulses and has zero power dissipation when off. To activate the implanted switch, the actuator antenna is positioned near the switch antenna; when the actuator is operated, a 700-kHz rf signal is radiated. The tuned, implanted antenna picks up the radiated signal which then actuates the switch, energizing the implanted sonomicrometer. The sonomicrometer can be turned off by a succeeding 700 kHz rf signal.

The sonomicrometer and the electronic switch are packaged in a cordwood-type configuration, with the

electronic components mounted in a plastic billet. The circuit components are hermetically sealed in a metal container, with the loop antenna connected through a two-pin glass header; the ultrasonic transducers and the battery are connected to a four-pin header at the other end. The electronic switch is also hermetically sealed within a metal container, which has a four-pin header for the antenna and other connections. A high-melting-point wax is used to encase and support the antenna and header connections. A single coat of a commercial vinyl compound is used over the wax to improve the adhesion of a commercial elastomeric material which is applied as a final coating.

The battery package for the system consists of two or three 1.35 V pacemaker mercury cells connected in series and encapsulated in a silicone rubber, coated with a vinyl compound for protection against body fluids. The ultrasonic transducers (a pair of 1-cm diameter piezoelectric crystals) are sealed in the vinyl compound and mounted in an expanded, cellular polystyrene unit coated with the vinyl compound.

Reference:

Lee, R.D.; and Sandler H.: Miniature Implantable Sonomicrometer System. *J. Appl. Physiol.*, 28(1), 110 (1970).

Notes:

1. The sonomicrometer circuitry can tolerate supply voltage variations in the range of 2.0 to 4.0 V.
2. Requests for further information may be directed to:

Technology Utilization Officer
Ames Research Center
Moffett Field, California 94035
Reference: TSP71-10163

Patent status:

No patent action is contemplated by NASA.

Source: Robert D. Lee
Ames Research Center
(ARC-10201)
Category 02,05