

February 1971

Brief 71-10018

# NASA TECH BRIEF

*Kennedy Space Center*



NASA Tech Briefs announce new technology derived from the U.S. space program. They are issued to encourage commercial application. Tech Briefs are available on a subscription basis from the National Technical Information Service, Springfield, Virginia 22151. Requests for individual copies or questions relating to the Tech Brief program may be directed to the Technology Utilization Office, NASA, Code KT, Washington, D.C. 20546.

## Vacuum-Jacketed Rotary Joints for Pipelines

A rotary joint mechanism can be used on vacuum-jacketed pipelines carrying liquified gases at ultralow temperatures. The design can easily be adapted to any pipes (particularly, insulated lines) transporting gases or liquids, including those that are noxious or corrosive.

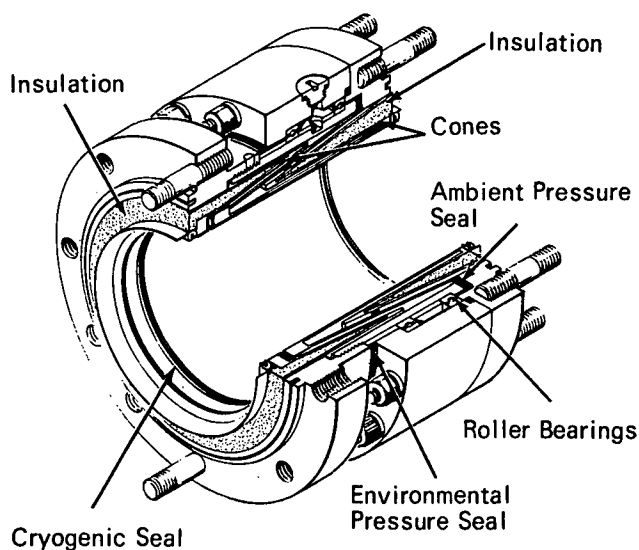

A jacketed pipeline transporting cryogenic liquified gas may require rotation points at various interfaces in the line—for instance, swinging arms at delivery points. Such rotation has been provided by flexible lengths of line which have thin walls easily damaged by impact or corrosion. In addition, these lines transmit the torsional loads applied to them. One objective in designing the new joint was to permit rotary motion while restricting heat loss to no more than that from a standard coupling.

The new joint (see fig.) absorbs all significant

torque and is as rugged as heavy metallic pipe. In addition, its thermal insulation compares with that of a length of flexible pipe. The calculated heat leak for a 20.32 cm (8 in.) rotary joint was 9240 watts (315 Btu/hr), while tests with liquid nitrogen showed a leak rate of 6717 watts (229 Btu/hr). No liquid leak was detectable when the joint was statically pressurized to 206.7 kN/m<sup>2</sup> (30 psi) with liquid nitrogen. When the joint was rotated at 24.15 rad/sec (3.2 rpm) with a side load of 3400 joules (2500 ft-lb), the torque required was 272 joules (200 ft-lb) and the leakage was less than 137 cm<sup>3</sup>/sec (5 in<sup>3</sup>/min) (standard). Joints measuring 15.24 cm (6 in) were also built and tested.

The rotary joint includes: a combination of a sliding cryogenic lip seal, a sliding ambient-pressure lip seal, an environmental lip seal, an insulation structure, conical-block insulation, and a roller-bearing arrangement, all of which permit low-torque rotation and restrict heat leak to that of a typical bayonet joint; incorporation of overlapping conical supports and thermally isolating members which reduce face-to-face dimensions; long-heat-path cones which greatly reduce heat input to the fluid; and bearings which remain at ambient temperature while cryogenic fluids are handled. With cryogenic fluid being transferred, the joint can be either stationary or rotating, and the primary lip seal will remain at ambient temperature.

Another interesting feature is that heat leakage to the fluid is reduced considerably by enclosing at least 90% of the joint in a vacuum to eliminate conduction and convection. Using a porous insulating block greatly reduces heat transfer between the fluid and the ambient-temperature jacket; the block prevents gas permeation and has a conductivity of less than 1.44 watts/m (0.15 Btu/hr-ft).

(continued overleaf)

**Note:**

The following documentation may be obtained from:

National Technical Information Service  
Springfield, Virginia 22151  
Single document price \$3.00  
(or microfiche \$0.95)

**Reference:**

NASA-CR-107244 (N70-31965), Vacuum Jacketed Umbilical Lines Technology Advancement Study

**Patent status:**

No patent action is contemplated by NASA.

Source: R. C. Mursinna of  
AMETEK, Inc.  
under contract to  
Kennedy Space Center  
(KSC-10519)