

NASA TECH BRIEF

Marshall Space Flight Center



NASA Tech Briefs announce new technology derived from the U.S. space program. They are issued to encourage commercial application. Tech Briefs are available on a subscription basis from the National Technical Information Service, Springfield, Virginia 22151. Requests for individual copies or questions relating to the Tech Brief program may be directed to the Technology Utilization Office, NASA, Code KT, Washington, D.C. 20546.

Saturable-Reactor Motor Starter Reduces Line Voltage Fluctuations

The problem:

To minimize line voltage fluctuations occurring when large motors 18,650 to 596,800 watts (25 to 800 horsepower) are started.

How it's done:

As the motor speed increases, the back EMF generated in the motor windings increases the saturation in the magnetic core of the reactor. This saturation reduces the counter EMF of the reactor coil, and the net effect is a reduction in reactor impedance. The reduced impedance permits more current to flow and the motor speed increases. In actual operation, the motor is started very slowly and uniformly accelerated until the normal operating speed is reached. The reactor coils are then switched out of the input power circuit.

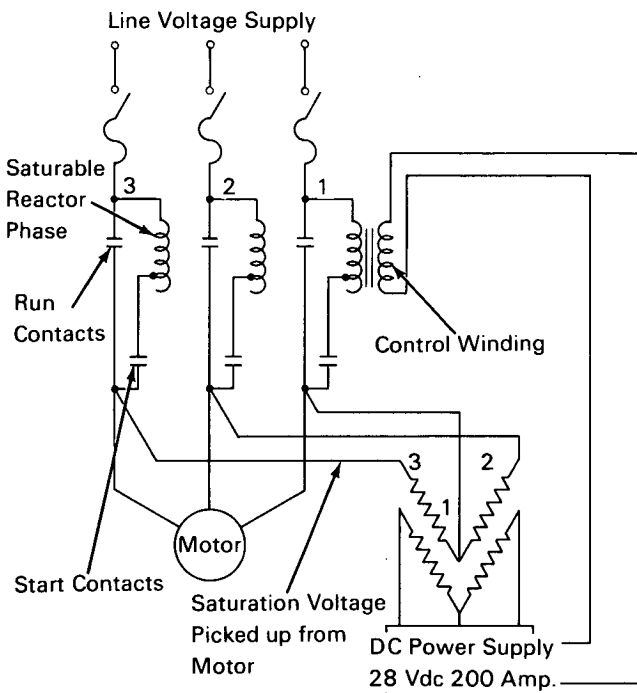

Advantages of the "soft-start" saturable reactor include simplicity and low cost. Supply line fluctuations are reduced and voltage regulators, which supply power to sensitive instrumentation, may be eliminated.

Note:

No additional documentation is available. Specific questions, however, may be directed to:

Technology Utilization Officer
Marshall Space Flight Center
Code A&TS-TU
Huntsville, Alabama 35812
Reference: B71-10013

Patent status:

No patent action is contemplated by NASA.

The solution:

A saturable reactor starter (see fig.) which uses the back electromotive force (EMF) generated by the motor to limit and control the starting current.

Source: Neil G. Currie of
North American Rockwell Corp.
under contract to
Marshall Space Flight Center
(MFS-18921)

Category 01