

Jan. 29, 1963

J. DIMEFF

3,076,065

HIGH-SPEED LOW-LEVEL ELECTRICAL STEPPING SWITCH

Filed Aug. 2, 1960

2 Sheets-Sheet 1

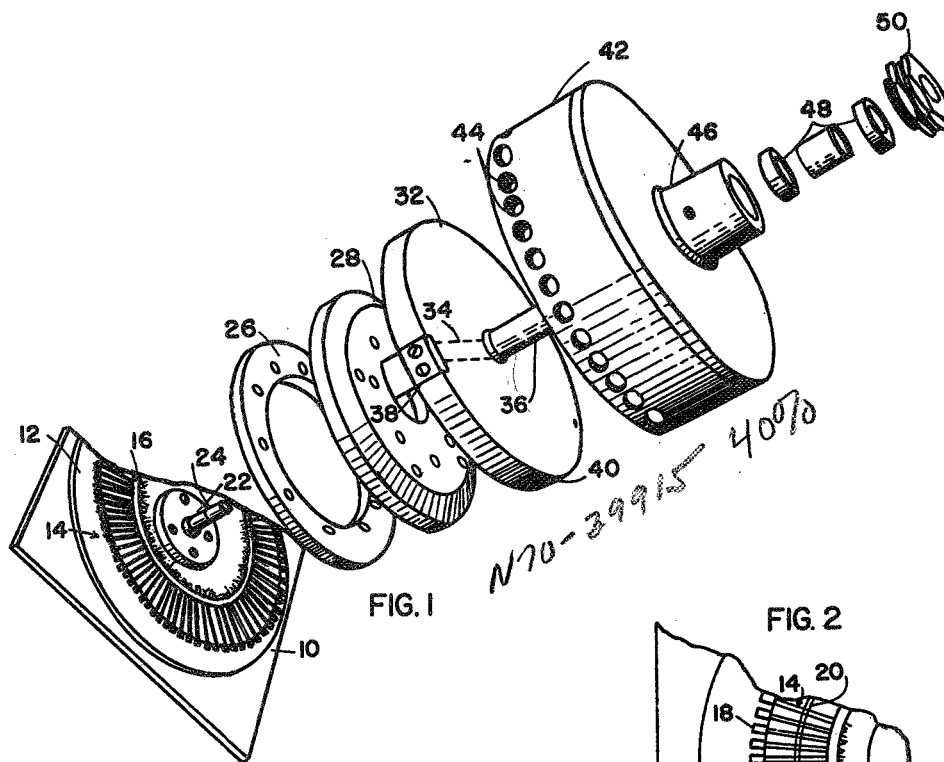

FIG. 1

N70-39915 40%

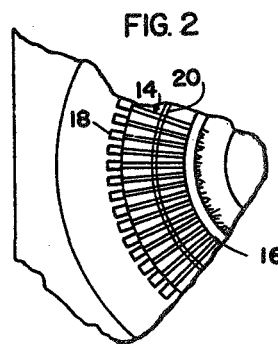

FIG. 2

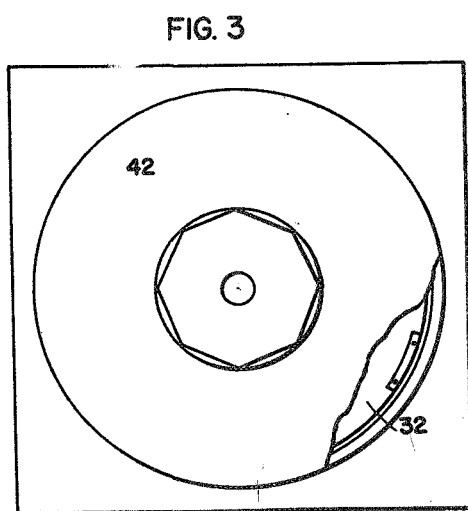

FIG. 3

INVENTOR.

JOHN DIMEFF

BY

R. D. Orr
W. F. Ross

ATTORNEYS

084

Jan. 29, 1963

J. DIMEFF

3,076,065

HIGH-SPEED LOW-LEVEL ELECTRICAL STEPPING SWITCH

Filed Aug. 2, 1960

2 Sheets-Sheet 2

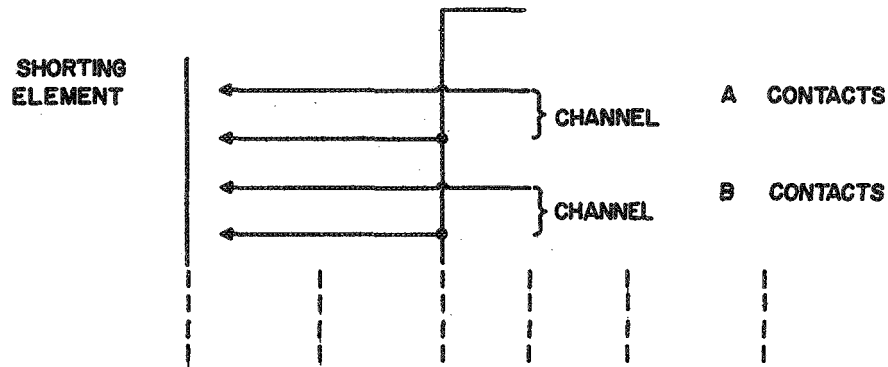

FIG. 4

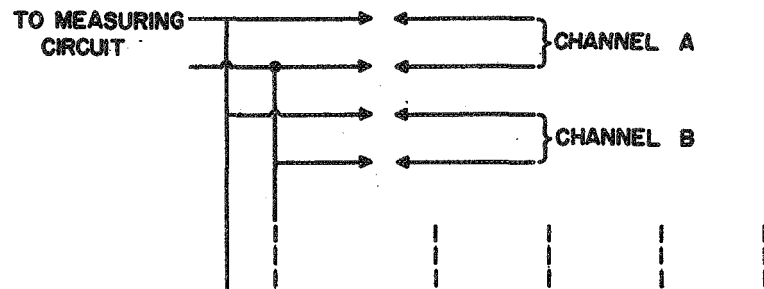

FIG. 6

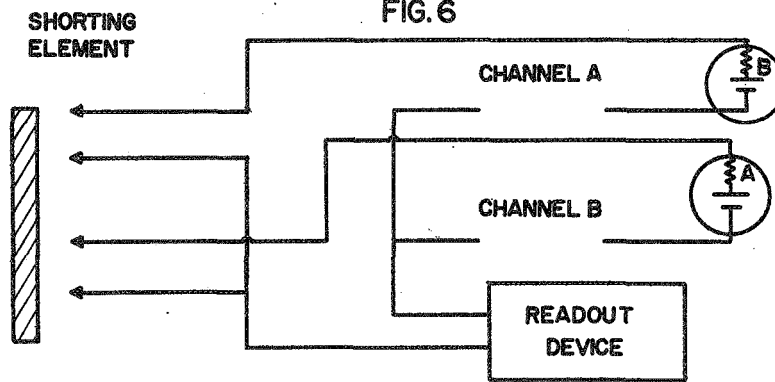

FIG. 5

INVENTOR.
JOHN DIMEFF
BY *[Signature]*
H F Pasa
ATTORNEYS

1

2

3,076,065
**HIGH-SPEED LOW-LEVEL ELECTRICAL
 STEPPING SWITCH**

John Dimeff, San Jose, Calif., assignor to the United States of America as represented by the Administrator of the National Aeronautics and Space Administration
 Filed Aug. 2, 1960, Ser. No. 47,121
 7 Claims. (Cl. 200-19)

(Granted under Title 35, U.S. Code (1952), sec. 266)

The invention described herein may be manufactured and used by or for the Government of the United States of America for governmental purposes without the payment of any royalties thereon or therefor.

This invention relates to a high-speed stepping switch, more particularly, it relates to a high speed commutating switch for low level voltage inputs. Prior art switching devices of the high-speed type involve the use of magnetic drive devices (as in the telephone cross bar switches); contacts in which the velocity of the moving vector past the stationary contact is related mechanically to the rate of switching (as in the telephone stepping switches); or devices which use a mercury jet to establish contact or deform a cylinder which in turn establishes contact with the stationary connections. These prior art devices are subject to the disadvantage that because of kinetic energies, friction heating and magnetic coupling they typically generate thermoelectric or electromagnetic noise voltages in their related circuits and are limited, therefore, to operation at slower speed where these noise voltages are small, or are limited to operation at higher input voltage levels where signal magnitudes are large enough to obscure the inherent noise levels.

It is therefore an object of this invention to provide a high-speed commutating switch for low voltage inputs, that is, voltages of the order of zero to one hundred microvolts.

It is another object of this invention to provide a high-speed commutating switch to connect to and provide a sample of each of a series of low level voltages connected to its various inputs.

It is a further object of this invention to provide a high-speed stepping switch for low level voltages which operates without the introduction of appreciable electrical error voltages from heat, friction and other sources, or without appreciable noise while being switched from one channel to another at high speed.

The invention is best described by reference to the accompanying drawings; hereby made a part of this application and in which,

FIG. 1 is an exploded view of the device;

FIG. 2 is a fragmentary section of the base plate of the devices showing the contact pairs in detail;

FIG. 3 is a top plan view of the assembled device partially cut away;

FIG. 4 is a schematic circuit diagram illustrating the manner in which various channels are switched;

FIG. 5 is a schematic diagram similar to that of FIG. 4 showing the inputs as transducers, and showing the manner of connecting inputs to a readout device, analog computer, and recording device in a typical application of the invention, and

FIG. 6 is a schematic diagram showing the switching arrangement for a modification of the invention.

Referring now to FIG. 1, a base plate 10 is shown provided with plate 12 on which are mounted symmetrical contact pairs 14 of conductors, each pair representing an input channel. The conductors are made of gold plated copper, gold, or other suitable material, and they have sufficient stiffness and rigidity to be supported horizontally as respects the mounting point. They are mounted by means of insulating support ring 16, which is super-

imposed upon base plate 10, with their terminals extruding inwardly as shown for connection to the individual output channels of voltage to be measured. Each contact pair 14 is connected at its ends by insulating nylon actuating tips 18. The tips hold the wires out of contact with each other. A circular shorting bar 20 (see FIG. 2) of conductive material is secured on the base plate beneath the contact pairs between the point at which the pairs are mounted and the nylon tips. Auxiliary plate 22 is mounted on the plate 12 centrally thereof, supporting a stationary air supply pipe 24 extending upwardly therefrom. For supporting the contact pairs in the proper position, contact clamping ring 26 of nonconducting material, such as, nylon, is placed over the contact pairs and secured to the base plate 10 by bolting shield 28 to the base plate with bolts which extend through shield 28 and clamping ring 26 and between contact pairs 14 into the base plate 10. The contact pairs 14 are spaced from the base plate 10 and shorting bar 20 by the superimposed support ring 16. The extremities of the contact pairs are then free to move toward the base plate 10 and make contact with the shorting bar to complete a circuit; however, have restrained movement in the opposite direction beyond the normal rest position by the clamping bar 26 which overlies the inner portions of the contact pairs. Shield 28 also serves to protect the contact pairs from air currents. When the clamping ring 26 and the shield 28 are in position the outer edge of the shield 28 lies between the tips 18 and the point at which the contact pairs are mounted. Rotor 32 is mounted to rotate above shield 28 as will be described later. The rotor 32 is provided with an internal air channel 34 shown in phantom leading from hollow spindle or shaft 36 to air nozzle actuator 38. The air nozzle actuator 38 is fastened to the rim 40 of rotor 32 by bolts or screws as shown. The diameter of rotor 32 is greater than that of shield 28 and is such that the actuating nozzle is directly above the nylon contact points 18 when the device is assembled. When rotor 32 is assembled in operating position over shield 28, pipe 24 extends upwardly within hollow spindle 36. An O ring, not shown, between the outer surface of pipe 24 and the inner surface of the hole through rotor 32 through which pipe 24 extends into hollow spindle 36 prevents the passage of air around the outside of pipe 24 and over the surface of shield 28. The O ring is located below air channel 34. The spindle 36 is closed at its upper end (not shown) so that air entering pipe 24 under pressure is forced through internal air channel 34 and out through the air nozzle actuator 38 on to nylon contact tips 18. To complete the assembly, a disc-shaped cover plate or housing 42 is mounted securely to the base plate by bolts or otherwise. The cover plate 42 is of sufficient height so that when bolted into position its internal top surface clears the top surface of rotor 32 so that the rotor will rotate without touching it. The cover plate 42 is provided with air access holes 44 to permit the escape of air ejected through air nozzle actuator 38. The hollow spindle 36 is mounted for rotation so that it is in the proper position to rotate with respect to shield 28 without touching it and also in proper position so that air nozzle actuator 38 is at the required height above tips 18. The hollow spindle passes up through support ring 46 the bearing and spacer assembly 48 and nut 50 protruding on beyond nut 50 so that it can be driven by direct drive or otherwise. The bearing and spacer assembly 48 has a total combined thickness to provide positioning of rotor 32 in the proper position. The assembly is secured in place by means of nut 50. The rotor may be driven by any conventional means.

Referring now to schematic circuit diagrams 4 and 5, the manner of sequentially switching the separate channels into a recording device by means of the pairs of

3

conductors leading from each channel is shown. Typically, an individual electrical circuit is connected to the input of a measuring device by two contacts when the switch is operated. Multiple pairs of conductors, each pair representing a channel, are connected to the contact pairs at the insulating support ring 16. In the case of a circuit in which only one connection is required, the use of two contacts is accomplished as shown schematically in FIG. 4, in which connection between an individual channel and the measuring instrument is made by common and simultaneous connection of their similar contacts to a shorting element. When readings are required, rotor 32 is rotated at a predetermined speed while air is forced into the switch through pipe 24 and out air nozzle actuator 38. The stream of air contacting the nylon tips 18 causes sequential contact of each of the contact pairs 14 with the shorting bar. The resilient contact pairs which are supported out of contact with the shorting bar immediately spring away from the shorting bar when the air stream has passed on. The result is the contact of each contact pair with the shorting bar and instantaneous release therefrom after the air stream has passed on so that each channel is sequentially switched into the recording assembly to permit the voltage output of the channels to be recorded by means of the readout device, analog digital computer and recording device as shown in FIG. 5.

Referring to FIG. 6, there is shown a schematic diagram of a modification of the invention in which two separate similar contacts may be individually connected to the two similar electrical leads of the measuring instrument when this is required.

The above construction is designed to minimize the kinetic and thermo-energy that must be dissipated in the contacts on closure by, (a) the separate determinability of the speed at which the actuating mechanism is moved and the speed at which the contacts must rub in completing the circuit, (b) the low mass of the deflecting system, (c) the thermal separation of the contacts from the point at which the closing force is applied by a low thermal conductivity plastic, and (d) the shielding of the actual contacts from air currents generated by the motion of the actuator. The effect of the unavoidable minimum kinetic and thermal energy associated with the contact closure is minimized by, (a) providing a high degree of physical similarity in the parts, (b) constructing the contacts (stationary and movable) of a material of high thermal diffusibility, (c) constructing the stationary contacts to provide a high rate of conduction from one internal point to another, and (d) mounting contacts (stationary and movable) so as to maximize the rate of heat conduction to the body of the switch.

From the above description it is seen that there has been provided (a) a circuit arrangement involving two symmetrically arranged contacts for use in a high-speed, multichannel, single-pole switch, in which electrical error signals generated in one contact oppose and cancel error signals in the other contact, (b) a rotating mechanical actuator for a switch in which the contact is made by mechanical motion of a member separated from the rotating member and having separately determinable velocity and energies, (c) an arrangement for closure of a switch contact in which kinetic energy of the actuating device is expended at a point on the contact mechanism which is thoroughly insulated from the contact points and which therefore minimizes the flow of thermal energy from the actuating point to the electrical contact points, and (d) an arrangement for a sequential switch in which a nonconducting fluid stream is used for an actuating device.

It will be apparent from the above description that many modifications are possible in the light of the above teaching. It is, therefore, to be understood that within the scope of the appended claims the invention may be practiced otherwise than as specifically described herein.

4

What is claimed is:

1. A high speed commutating switch for sequentially measuring the voltage from a plurality of low-voltage inputs comprising a plurality of pairs of conductors connected to the voltage sources to be measured, a conducting element disposed intermediate the extremities of said pairs of conductors, and means engaging one of the extremities of said contact pairs for sequentially contacting each of said contact pairs to the conducting element and sequentially disconnecting them.

2. A high speed commutating switch for sequentially connecting a plurality of input voltages to a recording device, comprising multiple contact pairs of conductors, each pair connected at one extremity to an input to be measured, each conductor of said pairs being separated at the other extremity by insulating material, said contact pairs being circularly arranged, a conductive element disposed intermediate the extremities of and in proximity to said contact pairs, first means engaging said insulating material for sequentially connecting each of said contact pairs with said conductive element, and second means for sequentially disconnecting said contact pairs.

3. The switch of claim 2 in which said means for connecting said contact pairs with the conductive element is an air current.

4. A high speed commutating switch for sequentially connecting a plurality of voltage inputs to be measured to a recording device, comprising, a base plate, a plurality of contact pairs of conductors mounted on said base plate in circular arrangement at one extremity of the pair, the other ends of the pairs of conductors being connected by a tip of nonconducting material, a circular shorting element immediately beneath said contact pairs approximately midway between the point at which they are mounted and the tips, said contact pairs being spring biased out of contact with said contact shorting element, a rotor mounted to rotate above said rotor directly above said nonconducting tips, means for forcing air under pressure out of said actuating nozzle, said rotor adapted to be rotated at a predetermined speed by power means; whereby as said rotor is rotated air from the nozzle causes sequential contact of each contact pair with the shorting bar and the spring biased condition of said contact pairs effects immediate release of said contact, and the contact pairs sequentially contacting said shorting bar being adapted to provide signals for measuring and recording equipment.

5. A high speed commutating switch for sequentially connecting voltage inputs to be measured to a recording device, comprising, a rectangular base plate; a raised portion on said base plate; a shorting bar on said raised portion; an insulating ring on said raised portion; a plurality of contact pairs of conductors affixed by one end to said insulating ring in circular arrangement; a non-conducting tip connecting the other ends of said contact pairs and holding them separated, said contact pairs being spring biased out of contact with said shorting bar; a centrally positioned auxiliary plate on said raised portion; an air pipe supported in said auxiliary plate and extending inwardly therefrom; an insulating circular clamping ring clamped over said contact pairs immediately outward from said insulating ring; a dish shaped clamping shield adapted to enclose said contact clamping ring mounted over said ring and having a beveled surface on its outer edge; a circular rotor adapted to fit over said shield for rotation, said rotor being dish shaped, and having a diameter greater than that of said shield; an air nozzle actuator secured to the rim of said rotor so that its outlet is directly over said contact points, said rotor having a hollow spindle extending upwardly from its center and enclosing said air pipe when assembled, said spindle being closed at its upper end, said rotor being provided with an air channel connecting said hollow

5

spindle and said air actuating nozzle whereby air forced through said pipe is forced out said nozzle onto said contact points; a dish shaped cover plate provided with air exits at the bottom of its outer edge adapted to fit over the assembly of base plate, shield and rotor and of sufficient depth so that its internal top surface clears the top surface of said rotor, said top plate being provided with a central orifice and a supporting ring thereover having a bearing surface therein, said hollow spindle extending upwardly through said supporting ring; said spindle and rotor adapted to be driven by power means, and the contact pairs sequentially contacting said shorting bar being adapted to provide signals for measuring and recording equipment.

6. The switch of claim 4 wherein shield means is positioned between said rotor and said contact pairs whereby the area of engagement of said contact pairs

6

with said shorting bar is shielded from air currents generated by said rotor.

7. The switch of claim 4 wherein said rotor and contact pairs are housed within a cover plate fixed to said base plate, said cover plate having holes in the vicinity of said nozzle to permit escape of air facilitating heat dissipation.

References Cited in the file of this patent

UNITED STATES PATENTS

2,365,218	Rogers	Dec. 19, 1944
2,501,431	Ausman et al.	Mar. 21, 1950
2,773,665	Berger	Dec. 11, 1956
2,773,951	Finlay	Dec. 11, 1956
2,808,549	Vandeventer	Oct. 1, 1957
2,852,636	Block et al.	Sept. 16, 1958
2,855,473	Rabinow	Oct. 7, 1958