

1170-36846

April 27, 1965

JAMES E. WEBB  
ADMINISTRATOR OF THE NATIONAL AERONAUTICS  
AND SPACE ADMINISTRATION

3,180,264

COUPLING FOR LINEAR SHAPED CHARGE

Filed Sept. 10, 1962

2 Sheets-Sheet 1

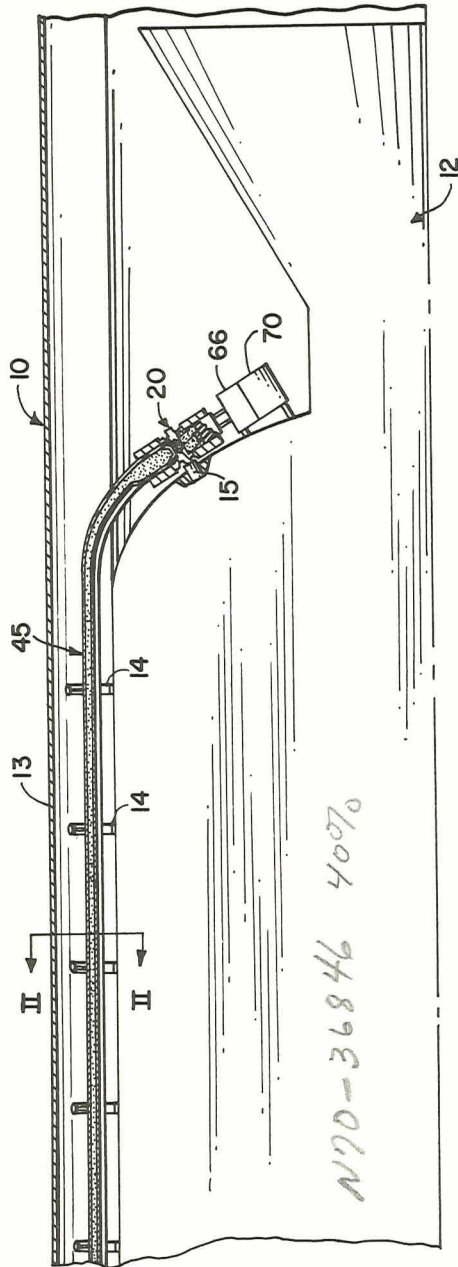

FIG. 1

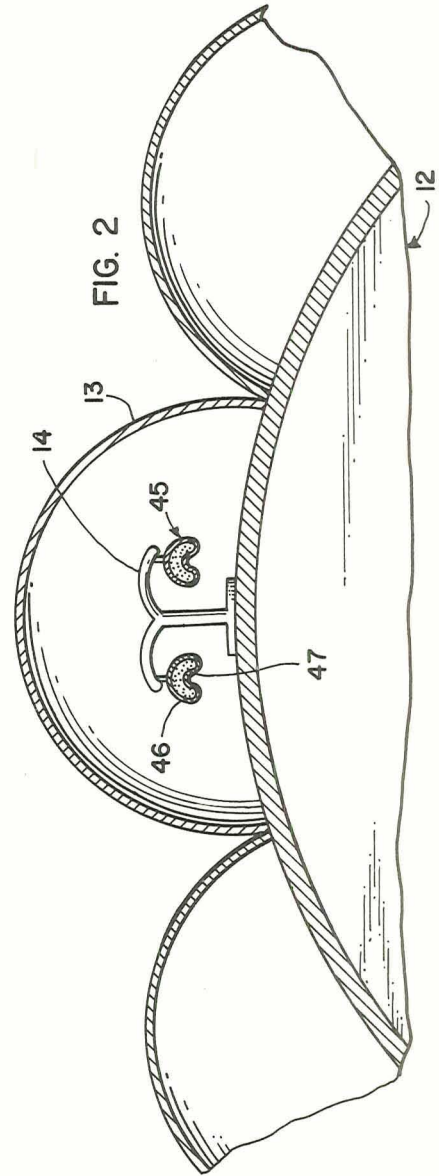

FIG. 2

INVENTOR  
HOMER T. ARMSTRONG

BY

*G. W. O'Brien*

ATTORNEY

523



UTILITY FORM 602

N70-36846 (ACCESSION NUMBER) (THRU)

06 (PAGES)

0 (CODE)

33

April 27, 1965

JAMES E. WEBB  
ADMINISTRATOR OF THE NATIONAL AERONAUTICS  
AND SPACE ADMINISTRATION

3,180,264

Filed Sept. 10, 1962

COUPLING FOR LINEAR SHAPED CHARGE

2 Sheets-Sheet 2

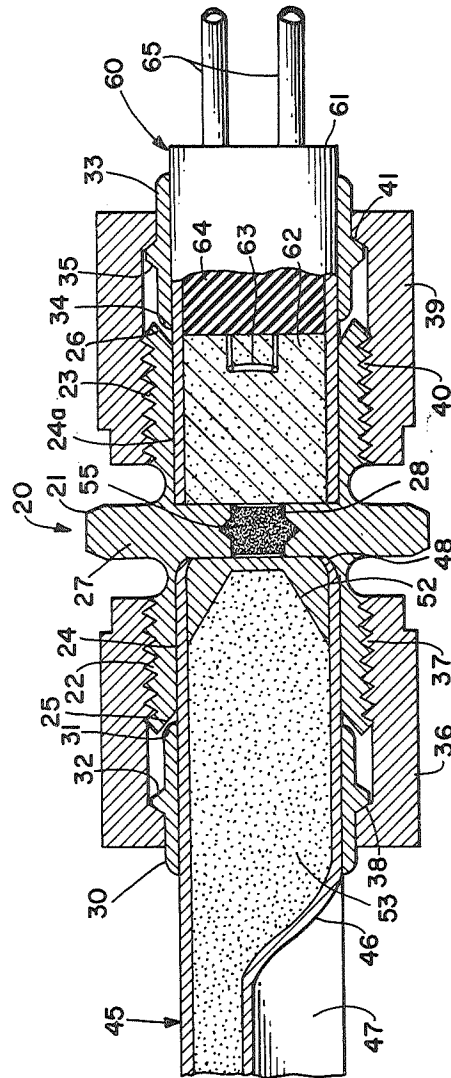

FIG. 3

INVENTOR  
HOMER T. ARMSTRONG

BY

ATTORNEY

1

2

3,180,264

## COUPLING FOR LINEAR SHAPED CHARGE

James E. Webb, Administrator of the National Aeronautics and Space Administration, with respect to an invention of Homer T. Armstrong, Arlington, Tarrant County, Tex.

Filed Sept. 10, 1962, Ser. No. 223,003  
13 Claims. (Cl. 102-49)

The invention described herein may be manufactured and used by and for the Government of the United States of America for governmental purposes without the payment of any royalties thereon or therefor.

This invention relates to a space vehicle abort system, and more particularly to a coupling for a linear shaped charge in the abort system.

Space vehicles upon occasion of malfunction must be destroyed. The common method of destroying the vehicle is that of rupturing the pressure chamber of the propulsion unit by some mechanism. When the propulsion unit is in operation and the pressure chamber is ruptured, explosion occurs due to the tremendous pressure confined within the chamber resulting in the destruction of the space vehicle. Various mechanisms have been employed to rupture the propulsion unit, one of the most common being the shaped charge. In the abort system, the shaped charge is arranged to lie adjacent the propulsion unit such that when detonated the rupturing process is fast and sure. Due to its physical location with respect to the propulsion unit the explosive used in the shaped charge must be of a nonvolatile nature to prevent detonation thereof by the heat generated within the propulsion unit. It is, therefore, necessary to utilize additional mechanism or mechanisms to ignite the shaped charge explosive. This is normally accomplished by the utilization of a booster charge and a safe-arm squib. Prior art methods of arranging the shaped charge, booster charge, and squib into an operative arrangement has necessitated a custom-made mechanism. In other words, it has previously been necessary to design a structure each time a shaped charge is used. Obviously, such an operation is not good engineering practice nor economically justifiable.

The present invention overcomes the difficulties of prior arrangements by the utilization of a simple coupling device which is used to join the shaped charge, booster charge, and squib into a compact unit. The coupling is designed such that the shaped charge is received at one end and the squib at the other end. The booster charge is housed by the coupling intermediate the ends of the shaped charge and the squib. The coupling is amenable to mass production and is of a nature such that with simple modifications it can be universally adapted to different sized shaped charges and squibs.

In view of the foregoing, it is an object of this invention to provide a device for coupling a shaped charge to a mechanism for detonating the shaped charge.

Another object of this invention is to provide a coupling which facilitates the assembly of the various components of a space vehicle abort system.

Yet another object of this invention is to provide a coupling for joining together a shaped charge and squib, the coupling operating as a retainer for an intermediate booster charge.

Still another object of this invention is to provide a universal-type coupling which can be utilized to join various sized shape charges and squibs.

A further object of this invention is to provide a device for controlling the powder density of the shaped charge which can be used in combination with a coupling for a shaped charge and squib.

Yet another object of this invention is to provide a

coupling for connecting a shaped charge to a squib which is of a simple design and is therefore economical to manufacture.

These and other objects and advantages of the invention will become more apparent upon reading the specification in conjunction with the accompanying drawings.

In the drawings:

FIG. 1 is a segmental view of a propulsion unit, partly in cross section, showing the abort system and coupling somewhat enlarged for purposes of clarity;

FIG. 2 is a cross sectional view taken along the section lines II—II of FIG. 1, also enlarged for clarity;

FIG. 3 is a cross sectional view of the coupling with a shaped charge and squib joined thereto taken along the longitudinal axes of the coupling.

Basically, this invention relates to an abort system which utilizes a standardized coupling arrangement for joining together the various components of the system. The shaped charge is of the linear type and suspended from and along a considerable length of the propulsion unit pressure chamber. One end of the shaped charge is received by a bore formed in the coupling. This end of the coupling has a series of external threads which are engaged by the threads of a nut. A sleeve surrounds the shaped charge and has a shoulder which is engaged by the nut. A surface of the sleeve coats with a surface formed on the end of the coupling such that when the nut is tightened the shaped charge is clamped to the coupling. The opposite end of the coupling is of the same basic design and is utilized to clamp the squib in place. An intermediate wall or partition separates the ends of the shaped charge and squib and also operates as a retainer for a booster charge. When the squib is ignited, it detonates the booster charge which in turn fires the shaped charge. The squib may be ignited by various mechanisms such as an electrical element or a percussion cap.

Referring now more specifically to the details of the invention, FIG. 1 illustrates the abort system designated generally by the reference numeral 10.

The abort system 10 includes the propulsion unit 12 which is partially shown and may be of existing designs. Surrounding the propulsion unit are a series of shell like conduits 13 (FIG. 2). The conduits 13 provide means for the guidance and control system as well as other electrical, hydraulic, or pneumatic plumbing. Also included in at least one of the conduits 13, and in some instances two or more of the conduits, are generally T-shaped hangars 14. The hangars 14 are positioned at spaced intervals throughout the length of the propulsion unit pressure chamber. Linear shaped charges 45 (to be explained more fully hereafter) are suspended from the hangars and directed such that when fired they will sever or rupture the wall of the propulsion unit. The hangars 14 are connected to the wall of the propulsion unit in a conventional manner such as by welding. A coupling support bracket 15 is also secured to the propulsion unit 12 in a conventional manner such as by welding. The coupling support bracket 15 (FIG. 1) is of a conventional design and for purposes of illustration may be a split collar which separates to receive the coupling and when assembled rigidly secures the coupling in position with respect to the propulsion unit 12.

The coupling per se is designated generally by the reference numeral 20 and is best illustrated in FIG. 3. It has a body or what may be termed a union 21. The union 21 has external threads 22 and 23 which are cut in the respective ends thereof. A bore is formed through the union 21 having enlarged ends 24, 24a and a reduced central area 28. As shown in FIG. 3, the bores 24 and 24a extend into the union approximately  $\frac{3}{4}$  the distance to the center from either end of the union. This leaves a wall or partition 27 intermediate the ends of the union on

3

which the reduced portion of the bore or chamber 28 is formed. The chamber 28 has a groove formed in the peripheral surface thereof to facilitate the retention of a booster charge to be explained more fully hereafter. The ends of union 21 have tapered surfaces 25 and 26, directed downwardly and inwardly. These surfaces cooperate with the sleeves 30 and 33 now to be described.

Sleeve 30 is a generally cylindrical shaped member which surrounds the end of the shaped charge 45, as illustrated in FIG. 3. The sleeve has wedge-shaped ends 31 which are slanted at approximately the same angle as tapered surface 25 for purposes which will be explained more fully hereafter. A raised flange 32 is positioned on the outer periphery of the sleeve 30 and is adapted to cooperate with a coupling nut as will be shown presently. The sleeve 33 is substantially identical in design to that of the sleeve 30, having wedge-shaped ends 34 and a flange 35. Since these members are essentially identical, they are interchangeable. The thicknesses of the sleeves 30 and 33 as viewed in cross section may be varied to change the inside diameter thereof, providing a means whereby shaped charges or squibs of varying diameters may be coupled. The coupling 20 thus has the nature of a universal type of fitting by merely varying the inside diameter of the sleeves. Although coupling may be accomplished in this manner, it is preferred that the inside diameter of the sleeves be essentially that of the bore 24.

The nut 36, having internal threads 37, engages the threads 22 of the union 21. An angular groove is cut in the inside diameter of the nut 36 to form the shoulder 38. The shoulder 38 engages the flange 32 of sleeve 30 as shown in FIG. 3. This provides a means whereby when the nut 36 is tightened or advanced toward the center of the union the sleeve is carried therewith to provide a wedging or clamping action in a manner which will be explained more fully in the operation of the invention. The nut 39 is similar to the nut 36 having internal threads 40 and a shoulder 41. The shoulder 41 operates upon the flange 35 of sleeve 33 in a manner similar to that mentioned immediately above.

The shaped charge 45 is of a tubular construction and may be formed from a metal such as aluminum. It has a cylindrical end 46 which is adapted to be received by the coupling 20 and a shaped groove 47 which is otherwise formed throughout the longitudinal extent of the tube. As shown in FIG. 2 the shaped groove 47 is directed in a manner such that when fired it will cut the casing of propulsion unit 12. Two linear shaped charges 45 are shown suspended from the hangar 14 in FIG. 2; however, it is to be understood that within the broadest aspect of the invention one or more shaped charges can be used.

An inverted, conical-shaped press plug 52 may be placed in the cylindrical end 46 of the shaped charge and held in position by crimping 48. The press plug 52 is utilized to control the density of the explosive powder 53 which fills the shaped charge. The crimping 48 provides a means for fixing the press plug in position, but does not interfere with the coupling action. The explosive 53 is a conventional detonating powder which is commercially available.

As shown in FIG. 3, a booster charge 55 is retained within the chamber 28 of partition 27. The booster charge 55 may be an explosive commonly known as RDX, a primary or more sensitive explosive than the shaped charge explosive 53. As previously mentioned, the chamber 28 is grooved to provide a means for retaining the booster charge 55 in the coupling 20. The RDX powder is pressed into chamber 28 to form a cake completely filling chamber 28; or may be placed in the chamber 28 with a hardening agent which when set retains the powder in the coupling. This arrangement may be modified by removing the partition 27 and making the bore 24 of the same diameter throughout. With this arrangement, a plug of RDX is disposed intermediate the ends of the shaped charge 45 and squib 60, now to be described.

4

The squib 60 may be of any type which is commercially available, but is preferably of the type which is ignited by an electrical charge to facilitate its use in the particular environment of a space vehicle. For purposes of illustration, such a squib will be briefly described. The squib 60 has a casing 61 the end of which butts the booster charge 55, it being filled with a commonly known detonating powder 62. The igniting element 63, shown here as an electrical element, is embedded in the detonating powder 62 and supported by insulation 64. The igniting element 63 is electrically connected to wires 65 which in turn lead to a power supply 66 shown diagrammatically in FIG. 1. The power supply 66 is of a conventional nature such as a dry cell battery.

In order that the abort system 10 may be energized from the ground, a remote control 70, shown diagrammatically, is connected to the power supply 66. The remote control may include a receiver which upon receiving a signal from the ground closes a switch which will ignite the squib.

#### Operation

In operation, one or more shaped charges 45 may be suspended from the hangars 14 which are dispersed at equally spaced intervals along the propulsion unit 12 as shown in FIG. 1. The cylindrical end 46 of the shaped charge is positioned such that it may be received by the coupling 20. Before the cylindrical end 46 of the shaped charge is placed in the bore 24 of the coupling, the nut 36 and sleeve 30 are passed over the cylindrical end of the shaped charge. The sleeve 30 should have a sliding fit with the shaped charge 45. Under certain circumstances, this may require the selection of a sleeve having the proper inside diameter. The cylindrical end 46 of the shaped charge is then inserted in the bore 24 until it butts the partition 27 or a booster charge plug as the case may be. The nut 36 is threaded on the union 21. As the nut 36 advances its shoulder 38 engages the sleeve flange 32 and carries the sleeve along. Eventually, the wedge surface 31 of the sleeve engages the tapered end 25 of the union and coacts therewith. As the nut is further advanced or tightened, the sleeve 31 is compressed or constricted due to the wedge arrangement resulting in a clamping action. The end of the shaped charge 45 is thereby clamped in the coupling 20.

Normally the booster charge 55 has been previously installed in the coupling 20, particularly if it is of the design shown in FIG. 3. If it is a plug insert, it may be inserted in the opposite end at this point or may have been placed in the coupling previously, depending on the situation.

Assuming the wires 65 of squib 60 are properly connected to the power source 66, the squib 60 is now ready for coupling. Initially the nut 39 and sleeve 33 are passed over the squib casing 61. The end of the squib 60 is then inserted in the bore 24a until it assumes an abutting relationship with respect to the partition 27. The nut 39 is then screwed on to the union 21 and tightened. The sleeve 33 coacts with the end of the union 21 in a manner similar to that explained above causing the sleeve 33 to grip the squib 60 and thereby clamp it in position.

If several shaped charges 45 are utilized, each one is coupled to a squib in the manner previously described. A single power source 66 and remote control 70 is usually sufficient to energize one or several shaped charges.

If a space vehicle is launched and it is necessary to destroy the vehicle due to some malfunction, a command signal is sent from the ground to the remote control 70. This signal is received by the remote control 70 and through appropriate mechanism, the power supply 66 is energized. This results in a flow of current to the igniting element 63 which activates the powder 62. The igniting powder 62 is highly volatile and ignites rather easily. The booster charge 55 is fired by the burning of powder 62. The booster charge 55 provides a rather violent reaction which in turn detonates the more stable detonating

5

powder 53 of the shaped charge. When the shaped charge 45 is detonated, a majority of its explosive force is directed against the casing of the propulsion unit and is of sufficient strength so as to cut or rupture the casing. Due to the great pressure built up in the propulsion unit combustion chamber, a violent reaction takes place when its casing is ruptured resulting in the disintegration of the entire propulsion unit and thereby the destruction of the space vehicle.

From the above description it can be seen that an abort system is provided which has a minimum number of component parts which are arranged to best facilitate the destruction function. The utilization of the coupling to connect the shaped charge to the squib provides a quick and efficient means of assembly. The coupling is further susceptible to mass production and of a flexible design which permits its use with commercially available squibs and shaped charges. Otherwise, as stated, the coupling eliminates the necessity of a custom made abort system for each space vehicle. The coupling also operates as a protective element in the form of a heat shield for the squib. The coupling further provides a means for properly aligning the shaped charge, booster, and squib to increase the reliability of the abort system. Since these elements are essentially integrated by the coupling, the excessive vibration often encountered on lift-off has little or no effect on the system. The installation of an abort system is greatly simplified by utilizing the coupling, the shaped charge being joined to the squib by tightening two nuts and securing the coupling to its support bracket.

What is claimed and desired to be secured by Letters Patent of the United States is:

1. A quickly detachable coupling for a shaped charge adapted to be placed in an abort system or the like comprising: a union; a wall partially separating ends of said union; a booster charge retained by said wall; a shaped charge received by said union; a flareless sleeve surrounding said shaped charge; and a nut engaging said flareless sleeve and said union for rigidly connecting said shaped charge to said union; said union being immediately attachable or removable from said abort system upon tightening or loosening said nut.

2. A quickly detachable connector for a shaped charge adapted to be placed in an abort system or the like comprising: coupling means; shaped charge means; said coupling means receiving at one end said shaped charge means; first readily releasable clamping means for fixing said shaped charge means with respect to said coupling, detonating means received by the other end of said readily releasable clamping means; and second coupling means for securing said detonating means to said coupling means in the proximity of said shaped charge means; said coupling being immediately attachable to or removable from said abort system upon tightening or loosening said readily releasable first and second clamping means.

3. A quickly detachable connector for a shaped charge adapted to be placed in an abort system or the like as in claim 2 wherein said clamping means includes a sleeve; and a nut engaging said sleeve and said coupling forcing said sleeve to grip said shaped charge means.

4. A quickly detachable connector for a shaped charge adapted to be placed in an abort system or the like as in claim 2 wherein said detonating means is a squib; and electrical means associated with said squib for firing it remotely.

5. A quickly detachable connector for a shaped charge adapted to be placed in an abort system or the like as in claim 2 wherein said coupling has a rib for retaining a booster charge between said shaped charge means and said detonating means; and booster means retained by said rib.

6. A quickly detachable connector for a shaped charge adapted to be placed in an abort system or the like as in claim 2 wherein the end of the shaped charge means retained by said coupling has a press plug for providing the

6

proper powder density; and a housing forming a part of said shaped charge means and surrounding said press plug; and shaped charge crimping for fixing said press plug with respect to said shaped charge means.

7. A quickly detachable coupling adapted to be placed in an abort system or the like comprising: a union externally threaded at opposite ends; said union having a bore receiving at one end a shaped charge and at the other end a squib; a web formed in said bore separating said shaped charge and said squib, said web retaining a booster charge; sleeves surrounding said shaped charge and said squib; tapered surfaces formed on the ends of said union and cooperating with said sleeves, and nuts engaging said sleeves and said union external threads whereby when said nuts are tightened they force said sleeves against said tapered surface compressing said sleeves to clamp said shaped charge and squib in said coupling; said union being immediately attachable to or removable from said abort system upon tightening or loosening said nut; said union being universally adaptable to various size shaped charges by varying the size of said sleeves.

8. A quickly detachable coupling adapted to be placed in an abort system and the like as in claim 7 wherein said sleeves have flanges; said flanges being engaged by shoulders formed on said nuts.

9. A quickly detachable coupling adapted to be placed in an abort system or the like as in claim 7 wherein said sleeves have wedge-shaped surfaces complementary to said tapered surfaces formed on said union.

10. An abort system comprising: a propulsion unit; hangars supported by said propulsion unit; shaped charge means suspended from said hangars and extending along said propulsion unit; quickly detachable coupling means carried by said propulsion unit; said coupling means receiving at one end said shaped charge means; first readily releasable clamping means for fixing said shaped charge to said coupling, detonating means received by the other end of said coupling means, second readily releasable clamping means for fixing said detonating means to said coupling means in the proximity of said shaped charge, said detonating means when fired igniting said shaped charge thereby severing said propulsion unit which destroys itself.

11. An abort system as in claim 10 wherein said detonating means include a booster charge carried by said coupling and a squib clamped in said coupling; electrical means for igniting said squib, and remote control means for energizing said electrical means.

12. An abort system as in claim 10 wherein said coupling means include a union; said union having a bore receiving at one end said shaped charge means and at the other end said detonating means; sleeves surrounding said shaped charge means and said detonating means; and nuts engaging said sleeve and said union whereby when tightened said sleeves are compressed to clamp said shaped charge means and detonating means to said union.

13. An abort system comprising: a propulsion unit, shaped charge means directed against said propulsion unit; detonating means; quickly detachable coupling means detachably connecting said shaped charge means to facilitate assembly and disassembly of said abort system to said detonating means; and means for igniting said detonating means.

References Cited by the Examiner

UNITED STATES PATENTS

2,638,323	5/53	Bannon.	
2,679,380	5/54	Sweetman.	
2,934,014	4/56	Smith et al.	102-70
2,996,985	8/61	Kratzer	102-49 X

SAMUEL FEINBERG, Primary Examiner.

ARTHUR M. HORTON, Examiner.

5  
10  
15  
20  
25  
30  
35  
40  
45  
50  
55  
60  
65  
70  
75