

Sept. 28, 1965

D. M. SCHUSTER

3,209,360

ANTENNA BEAM-SHAPING APPARATUS

Filed Sept. 25, 1961

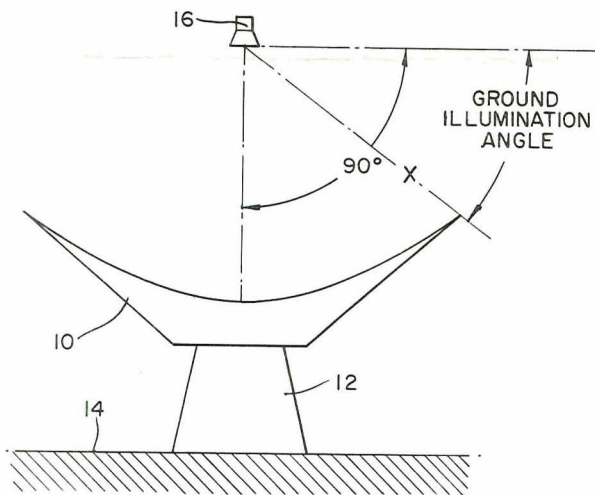

FIG. 1.

FIG. 2.

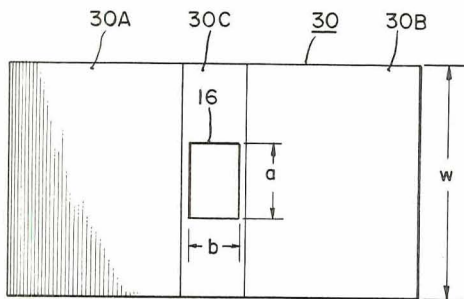
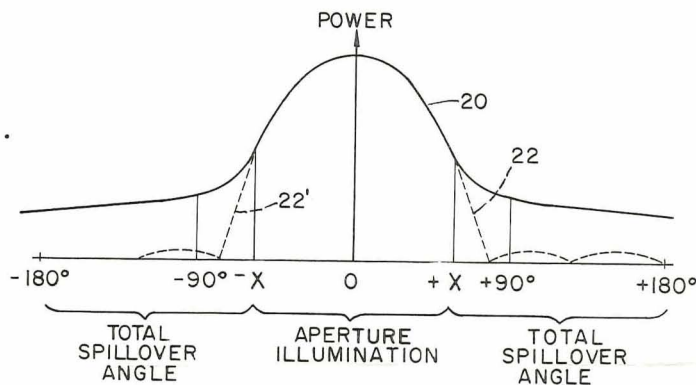

FIG. 3.

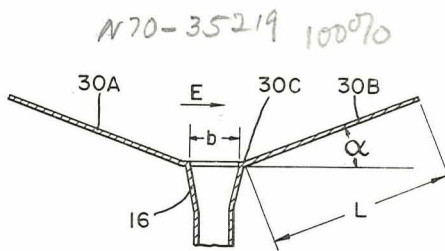

FIG. 4.

DANVER M. SCHUSTER
INVENTOR.

BY

Lyon & Lyon

ATTORNEYS.

N70-35219

FACILITY FORM 602	(ACCESSION NUMBER)	(THRU)
	3 (PAGES)	0 (CODE)
	✓ (NASA CR OR TMX OR AD NUMBER)	09 (CATEGORY)

403

1

3,209,360

ANTENNA BEAM-SHAPING APPARATUS

Danver M. Schuster, Altadena, Calif., assignor, by mesne assignments, to the United States of America as represented by the Administrator of the National Aeronautics and Space Administration
 Filed Sept. 25, 1961, Ser. No. 140,443
 2 Claims. (Cl. 343—781)

This invention relates to antennas of the type having a reflector dish and, more particularly, to improvements therein.

A typical paraboloidal antenna has a waveguide horn positioned at the focus for exciting the antenna and also for receiving any signals reflected therefrom. It is known that a considerable amount of power is wasted in the region outside of the paraboloidal-dish-illumination angle. This may be termed spillover power. A significant amount of power (at least eight to ten percent of the total) falls within the region known as the ground-illumination angle. The ground-illumination angle is the region included between a plane passing through the mouth of the horn perpendicular to the antenna axis and a line which connects the center of the horn mouth to the edge of the paraboloidal dish. Since ground-temperature radiation is usually the largest contributor to the antenna temperature of a receiving antenna, it is important to reduce the amount of spillover power in the ground-illumination region.

An object of this invention is the provision of structure for reducing the percentage of power received by a waveguide horn from the ground-illumination region.

Another object of this invention is the provision of a simple and improved structure whereby the efficiency of a paraboloidal-type antenna is increased either for receiving or transmitting.

These and other objects of the invention may be achieved in an arrangement whereby a conductive ground plane is positioned around the mouth of the wave-guide for preventing the H-plane component of the undesired power from being radiated into the ground-illumination region. The ground plane is also tilted at an angle in order to effectuate cancellation of the E-plane wave-pattern portion of the undesired radiation.

In an application for patent by Danver M. Schuster and David L. Nixon for Antenna Beam-Shaping Apparatus, filed September 25, 1961, Serial No. 140,509, which is assigned to a common assignee, there is shown and described a beam-shaping arrangement suitable for use with both linearly and circularly polarized waves. This invention is suitable for use with linearly polarized waves.

The novel features that are considered characteristic of this invention are set forth with particularity in the appended claims. The invention itself, both as to its organization and method of operation, as well as additional objects and advantages thereof, will best be understood from the following description when read in connection with the accompanying drawings, in which:

FIGURE 1 shows, for the purpose of illustration, an antenna of the general type with which this invention is employed;

FIGURE 2 is a graph showing, for comparative purposes, the energy distribution for the antenna of the type shown in FIGURE 1, without this invention and with this invention;

FIGURE 3 is a plan view of an embodiment of the invention; and

FIGURE 4 is a side view of the invention.

Reference is now made to FIGURE 1, which is a schematic view of the general type of antenna for which

2

this embodiment of the invention is intended. Such an antenna usually comprises a parabolic-dish reflector 10, supported on a base 12, which is positioned on the ground 14. A feed horn 16 is positioned approximately at the focus of the parabolic antenna. For the purposes of subsequent discussion herein, consider a line which is on the axis between the center of the parabolic dish 10 and the feed horn 16 as an axis or reference line; and the angle made between a plane perpendicular to the axis through the mouth of the feed horn and the reference line is 90° , and the angle made between the reference line and the tip of the antenna dish is an angle X_0 . The angle between X_0 and 90° is known as the ground-illumination angle. The angle between X_0 and 180° is the region in which spillover of the horn power occurs. A significant amount of received power comes from the ground-illumination angle over which the ground radiates thermal noise power into the horn, to cause noise signals which interfere with the desired signals reflected from the antenna dish.

Considering FIGURE 2, there is shown a plot of the distribution of the power radiated or received by the type of antenna shown in FIGURE 1 versus the angle made with the reference plane. The power-distribution curve 20 indicates a maximum power on the axis, or the zero-degree line, and then tapers off on either side of this line. The actual useful power is the power included between $+X_0$ and $-X_0$, which is known as the aperture illumination. The regions between $+X_0$ and $+90^\circ$ and $-X_0$ and -90° indicate the ground-illumination power. The power shown between $+X_0$ and $+180^\circ$ and $-X_0$ and -180° is the total spillover power. By employing structure as shown by this invention, the amount of the total spillover power is reduced substantially to the extent shown by the dotted lines 22, 22'. Effectively, the power radiated in the total spillover angle, and to a large extent within the ground-illumination angle, is attenuated considerably. This, of course, results in the thermal noise power being reduced considerably, whereby the antenna temperature is reduced. The antenna efficiency is improved because the power formerly wasted in spillover is now utilized in aperture illumination.

Referring now to FIGURE 3 and to FIGURE 4, in accordance with this invention, there is provided a large, flat ground plane 30 around the mouth of the horn 16. This ground plane may be made of any suitable conductive metal. This ground plane 30 effectively comprises three panels, two side panels 30A, 30B, which are tilted at some angle α with respect to a center panel 30C, which is effectively in the plane of the mouth of the horn 16. The use of a large, flat ground plane which is not bent at some angle α eliminates unwanted side and back radiation for the H-plane pattern, but not for the E-plane pattern. In the H-plane, the E-vector for the wide angle and the diffracted fields is everywhere parallel to the ground plane. One of the boundary conditions of electromagnetic theory requires that a tangential E-field go to zero at a conducting surface. Thus, when the diffracted field is reflected from the ground plane, it reverses phase, so that the total E-field is zero at the surface of reflection. At a small distance farther away, the diffracted and wide-angle fields will be out of phase and cancel.

Tilting the ground plane in the direction of the E-plane, as is done with panels 30A and 30B, produces a shielding effect, as far as the E-radiation pattern is concerned. The length L of the ground plane must be sufficient to reduce diffraction around the end of the ground plane. This has been found to be on the order of three wavelengths at the frequency at which the antenna is operated. The length L can also show a resonance effect for medium to small ground planes. The angle of tilt, $90^\circ - \alpha$, should be chosen to be about equal to the edge-illumination

3

angle, X_0 , of the dish. The width across the flat surface should be at least two to three times the wavelength at the frequency at which the antenna is operated. A width across the flat surface of four wavelengths was utilized in a test model.

This invention provides an improvement in the beam pattern, as represented by the dotted lines 22, 22' in FIGURE 3. This device is only suitable for use with linearly polarized signals. Effectively, it constitutes a large, flat ground plane for the H-plane and a tilted ground plane in the E-plane.

There has accordingly been described and shown herein a novel and useful arrangement for attenuating the power radiated from a dish-type antenna which causes deleterious effects whereby the operation of the antenna is considerably improved.

I claim:

1. The improvement for an antenna of the type having a reflector dish and a wave-guide horn for radiating energy at said reflector dish and for receiving energy therefrom, and wherein there is unwanted energy which radiates from said horn and does not reach said reflector dish, said improvement comprising ground-plane means adapted to be mounted about the mouth of said horn for eliminating side and back radiation for the H-plane component of said unwanted energy, said ground-plane means also being bent in the direction of the E-plane for eliminating the E-plane component of the side radiation of said unwanted energy.

2. The improvement for an antenna of the type having a reflector dish and a wave-guide horn for radiating energy at said reflector dish and for receiving energy therefrom, and wherein there is unwanted energy which radi-

4

ates from said horn and does not reach said reflector dish, said improvement comprising means for attenuating said unwanted energy including a ground plane adapted to be mounted at the mouth of said horn, said ground plane having a center portion extending in the plane of the mouth of said horn and two side portions bent in the same direction at an angle away from said center portion in the direction of the E-plane, each said side portions having a length on the order of three wavelengths of said energy, a width on the order of two to four times the wavelength of said energy, the angle at which said side portions are bent away from said center portion being substantially equal to the edge-illumination angle of said dish.

References Cited by the Examiner

UNITED STATES PATENTS

2,270,965	1/42	Peterson	343—912 X
2,283,935	5/42	King	343—783 X
2,470,016	5/49	Clapp	343—914 X
2,591,486	4/52	Wilkinson	343—786
2,617,937	11/52	Van Atta	343—786
2,636,987	4/53	Dorne	343—708
2,799,017	7/57	Alford	343—742 X
2,825,062	2/58	Chu et al.	343—781 X
2,840,819	6/58	McClellan	343—781

FOREIGN PATENTS

1,196,052 5/59 France.

ELI LIEBERMAN, *Acting Primary Examiner.*

HERMAN K. SAALBACH, *Examiner.*