

June 15, 1965

A. VARY

3,189,726

HIGH TEMPERATURE HEAT SOURCE

Filed Jan. 17, 1963

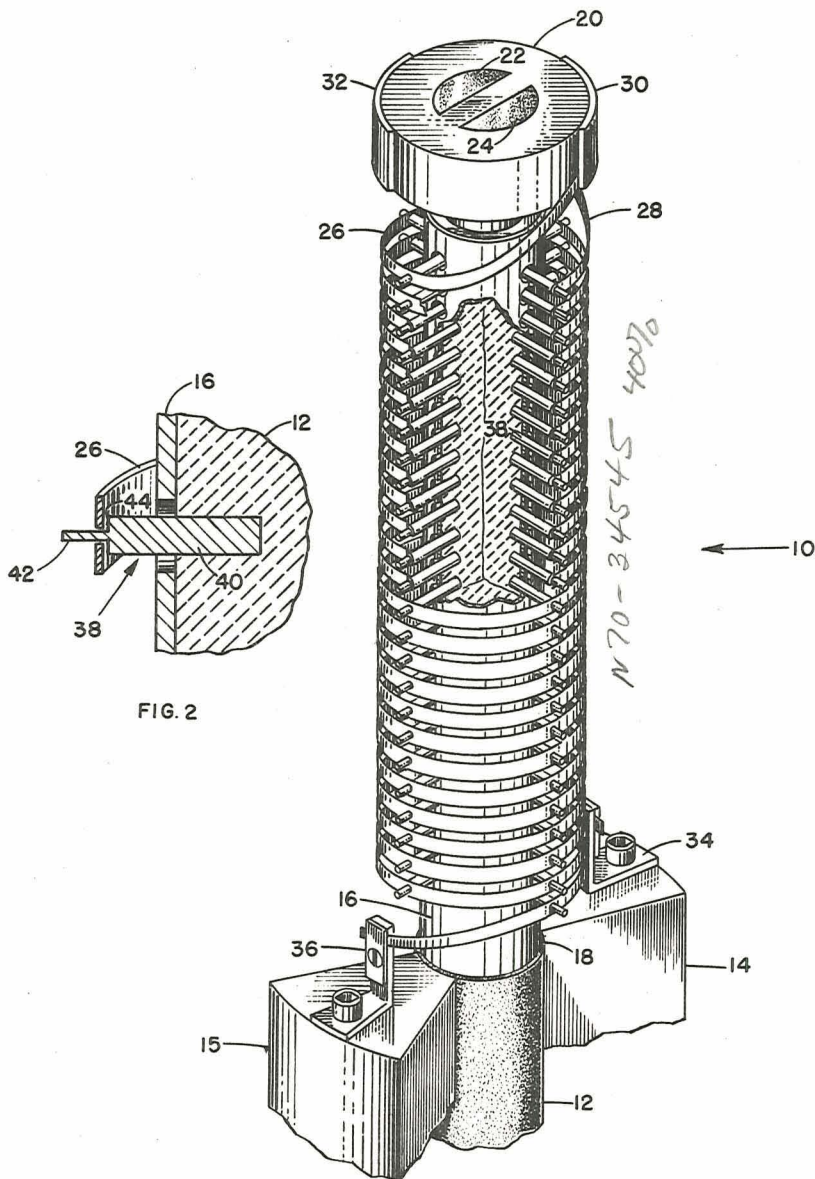

FIG. 2

FIG. 1

INVENTOR
ALEX VARY

BY *G. D. Stein*
Gene E. Shook ATTORNEYS

FACILITY FORM 602

N70-34545 (ACCESSION NUMBER) (THRU)

3 (PAGES) (CODE)

(NASA CR OR TMX OR AD NUMBER) (CATEGORY)

33

1

3,189,726

HIGH TEMPERATURE HEAT SOURCE

Alex Vary, North Olmsted, Ohio, assignor to the United States of America as represented by the Administrator of the National Aeronautics and Space Administration

Filed Jan. 17, 1963, Ser. No. 252,259

2 Claims. (Cl. 219-347)

(Granted under Title 35, U.S. Code (1952), sec. 266)

The invention described herein may be manufactured and used by or for the Government of the United States of America for governmental purposes without the payment of any royalties thereon or therefor.

The present invention is concerned with a high temperature source of thermal radiation and is primarily directed to means for heating emitter electrodes in thermionic devices. This invention is particularly concerned with a heat source which requires a low electrical current for operation and has a very low resultant magnetic field.

Various high temperature heat sources are presently available, and each type has certain disadvantages. For example, electron beam heating is not readily utilized for heating large surfaces and usually integrates the emitter into the heater circuitry. Wire heater elements are not only difficult to support but also restricted in size, and the temperature difference between the wire and object being heated is quite large. Tungsten, tantalum, and molybdenum ribbon elements have been used, but the required support mechanisms have made it necessary to limit the operating temperatures and to use heavy currents. Tubular heaters utilize heavy currents while plasma arcs likewise require heavy currents and have high magnetic fields. Induction heaters have the inherent disadvantage of high electromagnetic fields.

The aforementioned problems arising from the use of the above-listed devices of the prior art have been solved by the heater of the present invention which comprises a high temperature heat source that utilizes a pair of spaced heating elements in the form of ribbons that are curved to a helical configuration about a common center line. This provides a broad radiating surface which enables the object being heated to approach very closely the temperature of the ribbons. A plurality of support members extend radially outward from this common center line for slidably engaging the heating elements at spaced intervals to maintain them at a desired radial distance from the common center line while accommodating thermal expansion. These support members further prevent sagging of the heating elements at elevated temperatures while providing restraint against axial and circumferential displacement.

It is, therefore, an object of the present invention to provide a high temperature heat source having means for reducing the adverse effects of thermal expansion and stresses while maintaining the integrity of the material at high operating temperatures under continuous use.

Another object of the invention is to provide a highly efficient heat source with a resultant magnetic field of negligibly small magnitude.

Other objects and advantages of the invention will be apparent from the specification which follows and from drawings in which like numerals are used throughout to identify like parts.

In the drawings:

FIG. 1 is a perspective view, with parts broken away, illustrating the various structural features of a high temperature heat source constructed in accordance with the present invention; and

FIG. 2 is an enlarged sectional view of a portion of the heat source shown in FIG. 1 showing the detailed arrangement of the supports for the heating elements.

2

Referring now to the drawings, there is shown a high temperature heat source 10 that is constructed in accordance with the invention. The heat source 10 utilizes a centrally disposed support in the form of a ceramic post 12 that extends upwardly from a source of electrical current such as a pair of spaced bus bars 14 and 15 as shown in FIG. 1. A tubular radiation shield 16 such as a refractory metal sleeve fits over the center post 12 and extends upwardly from a shoulder 18 thereon that is adjacent the bus bars 14 and 15. The shoulder 18 positions this sleeve and prevents its axial displacement toward the bus bars 14 and 15. As shown in FIG. 2, the center post 12 contacts the inner surface of the radiation shield 16 which, in turn, protects the center of the heat source 10 from the high temperatures of the surrounding structure and increases heater efficiency by reflecting heat outwardly.

A generally circular cap 20 of an electrically conducting material is mounted on the uppermost portion of the center post 12 as shown in FIG. 1. A pair of upwardly directed protrusions 22 and 24 on the center post 12 extend through mating contoured openings in the cap 20 to prevent its rotation about the axis of the heat source 10.

According to the present invention, a pair of elongated heating elements 26 and 28 are curved to a helical configuration about the center post 12 and extend from the cap 20 to the bus bars 14 and 15. A pair of spaced clips 30 and 32 engage the upper ends of the elements 26 and 28 as shown in FIG. 1. The clips 30 and 32 are removably mounted on the cap 20 at diametrically opposed positions by screws or other suitable means and maintain the ends of the elements 26 and 28 in electrical contact with each other. The lower ends of the elements 26 and 28 are secured to angle brackets 34 and 36 respectively which, in turn, are mounted on the bus bars 14 and 15.

The elements 26 and 28 are in the form of ribbons of an electrically conducting material such as tungsten, tantalum, molybdenum or other refractory metals. These ribbons have a broad outer surface for maximum heat radiation as their temperatures are elevated by the passage of an electrical current furnished by the bus bars 14 and 15. This current is conducted up one of the ribbons, such as 26, from the bus bar 14 to the clip 30 where it passes to the other ribbon 28 at the clip 32 through the cap 20. The current is then conducted downwardly to the bus bar 15 through the other ribbon, and the resultant magnetic fields about the ribbons that are produced by the passage of this current cancel one another. Because the electrical potential of the bus bars 14 and 15 is relatively low, in the order of approximately fifty volts, the ribbons may be spaced relatively close together without arcing thereby providing maximum flux cancellation and heat radiation surface area.

An important feature of the invention is the provision of a plurality of elongated supports 38 which engage the heating elements 26 and 28 at intervals spaced closely enough to prevent sagging. The supports 38 are of an electrically conducting material such as tungsten, tantalum, molybdenum and other refractory metals and are rigidly mounted in the center post 12 as is shown in FIG. 2. Each support 38 includes a cylindrical body 40 extending radially outward from a common center line along the axis of the center post 12 through a clearance hole in the radiation shield 16. The diameter of each clearance hole is adequate to eliminate electrical shorting and to electrically isolate the radiation shield 16 from the supports 38.

A tip 42 extends outwardly from the body 40 of each support 38 through the adjacent heating element 26 or 28 as shown in FIGS. 1 and 2 to provide restraint against axial and circumferential displacement of these elements.

Each of the heating elements 26 and 28 is free to slide along the tip 42 in the direction of the axis of the support 38 to accommodate thermal expansion of the heating element. The tip 42 is cylindrical and of reduced diameter which forms a shoulder 44 at the intersection of the tip 42 with the body 40. A slight clearance is normally provided between the heating element and this shoulder as shown in FIG. 2. Movement of the helically curved ribbons in a radial direction relative to their common center lines along the tip 42 is limited by its engagement with the shoulder 44. This positions each segment of the heating elements 26 and 28 at a predetermined radial direction from the common center line within a limited range of variation.

While only one embodiment of the invention has been shown and described, various structural modifications may be made to the disclosed heat source without departing from the spirit of the invention or the scope of the subjoined claims. For example, while FIG. 1 shows the supports 38 engaging the ribbons 26 and 28 at spacings of ninety degree arcs, it is contemplated that these arcs may be made smaller or larger depending upon the material of the ribbons and the size of the heat source 10. Also while only two ribbons have been shown, it is contemplated that three bus bars carrying three-phase current may be connected by three separate ribbons, each of which constitutes a leg of a balanced three-phase circuit thereby providing maximum magnetic flux cancellation.

What is claimed is:

1. High temperature heat source, comprising a centrally disposed member, shielding means mounted on said centrally disposed member for reflecting heat outwardly, spaced heating elements helically curved about said shielding means and spaced outwardly therefrom, and a plurality of supports extending radially outward from said centrally disposed member through said shielding means to prevent the sagging of said heating elements and for restraining said heating elements from axial and circumferential displacement, each of said supports having an outwardly directed

tip portion in sliding engagement with one of said heating elements thereby enabling said heating element to move radially outward from said centrally disposed member along the axis of said support to accommodate thermal expansion and a shoulder portion adjacent the innermost end of said tip portion for engaging said heating element to limit the sliding movement thereof toward said centrally disposed member.

2. In a high temperature heat source of the type having an apertured heating element curved to a helical configuration about a center post, the improvement comprising

rigid members extending radially outward from the center post toward the heating element, each of said rigid members having an outwardly directed tip portion extending through one of the apertures in the heating element for providing restraint against axial and circumferential displacement of the heating element while accommodating thermal expansion of the same by enabling the heating element to slide along said tip portion, and each of said rigid members having a shoulder portion adjacent the innermost end of said tip portion for engaging the heating element to limit the sliding movement thereof toward the center post.

References Cited by the Examiner

UNITED STATES PATENTS

1,342,312	6/20	Steinberger	174—138 X
1,373,895	4/21	Leonard	219—343
1,432,411	10/22	Payne	338—318
1,433,960	10/22	Levin	338—282
1,883,927	10/32	Ipsen et al.	219—542
1,921,543	8/33	Schonfeld	338—297 X
1,976,522	10/34	Rose	140—71.5
2,217,296	10/40	Shaw	219—542 X
2,551,039	5/51	Nelson	219—349
2,795,765	6/57	Stroble	174—138 X
3,108,174	10/63	Hynes	338—319 X

RICHARD M. WOOD, *Primary Examiner.*