

Oct. 9, 1962

A. J. MEYER, JR., ET AL

3,057,597

MODIFICATION AND IMPROVEMENTS TO COOLED BLADES

Filed Aug. 20, 1959

5 Sheets-Sheet 1

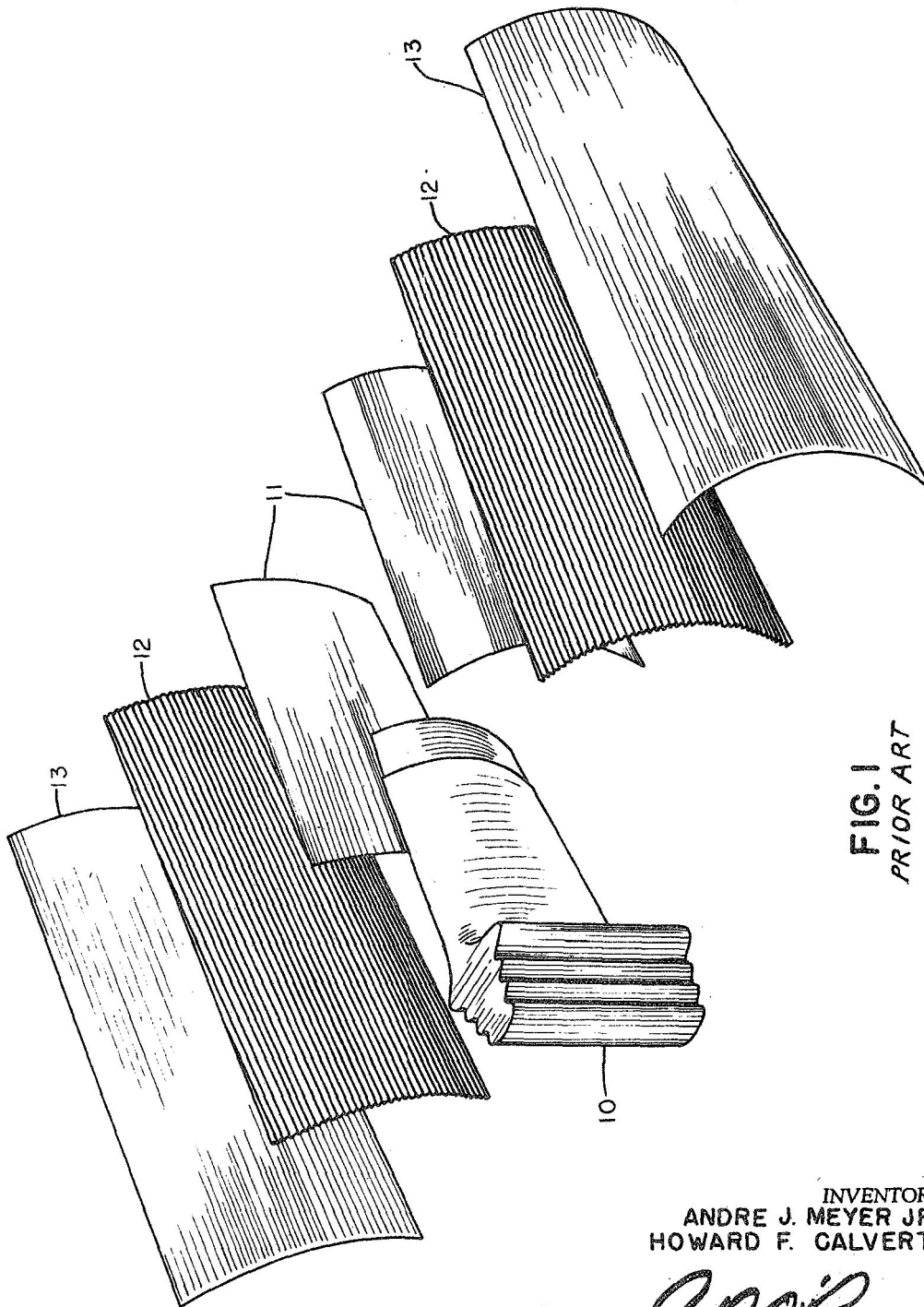

FIG. 1
PRIOR ART

INVENTORS
ANDRE J. MEYER JR
HOWARD F. GALVERT

BY

ATTORNEY

FACILITY FORM 602

N70-33264

(ACCESSION NUMBER)

(THRU)

7

0

(PAGES)

(CODE)

21

(NASA CR OR TMX OR AD NUMBER)

(CATEGORY)

Oct. 9, 1962

A. J. MEYER, JR., ET AL

3,057,597

MODIFICATION AND IMPROVEMENTS TO COOLED BLADES

Filed Aug. 20, 1959

5 Sheets-Sheet 2

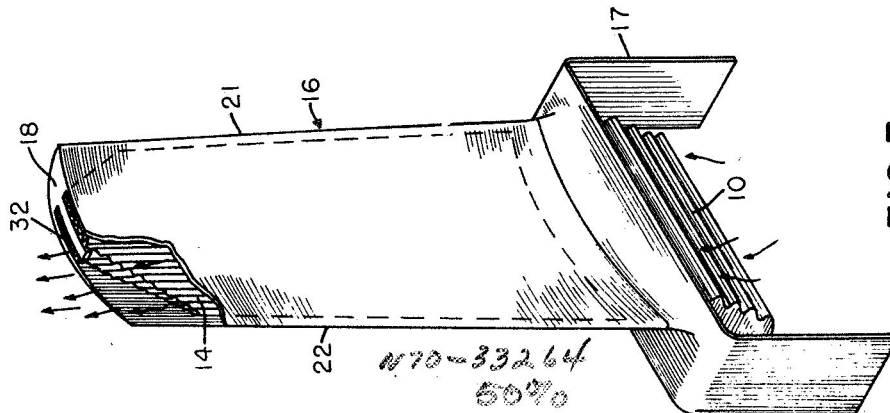

FIG. 3

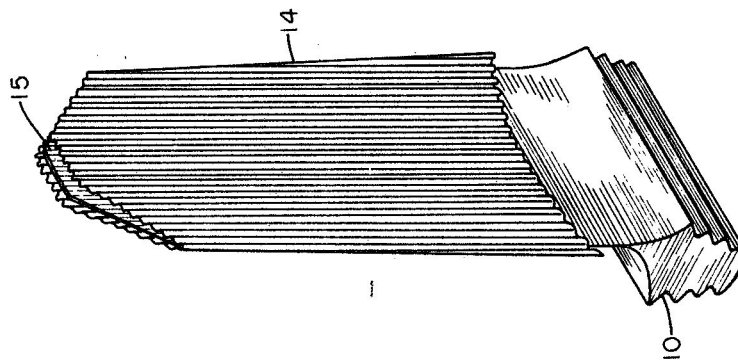

FIG. 2

INVENTORS
ANDRE J. MEYER JR
HOWARD F. CALVERT

BY

[Signature]
ATTORNEY

Oct. 9, 1962

A. J. MEYER, JR., ET AL

3,057,597

MODIFICATION AND IMPROVEMENTS TO COOLED BLADES

Filed Aug. 20, 1959

5 Sheets-Sheet 3

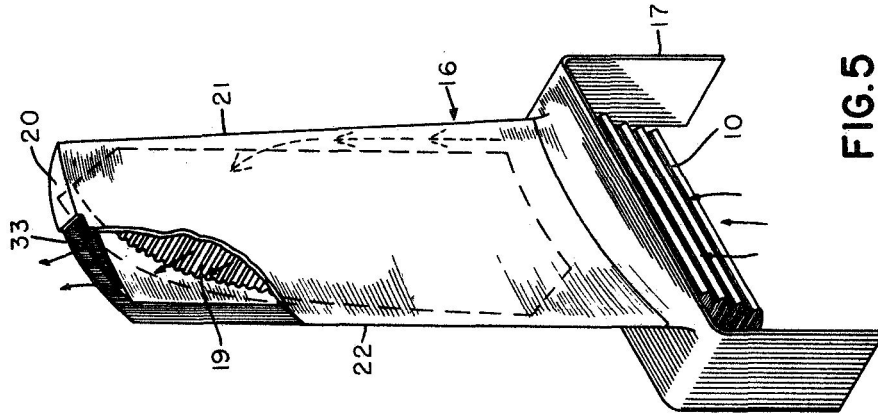

FIG. 5

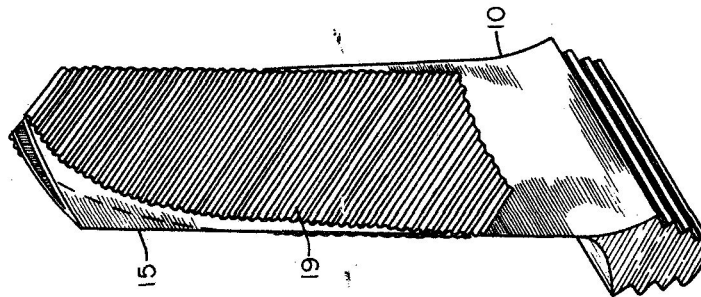

FIG. 4

INVENTORS
ANDRE J. MEYER JR
HOWARD F. CALVERT

BY

Q. D. O'Brien
ATTORNEY

Oct. 9, 1962

A. J. MEYER, JR., ET AL

3,057,597

MODIFICATION AND IMPROVEMENTS TO COOLED BLADES

Filed Aug. 20, 1959

5 Sheets-Sheet 4

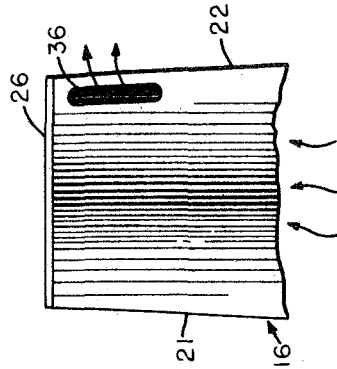

FIG. 8

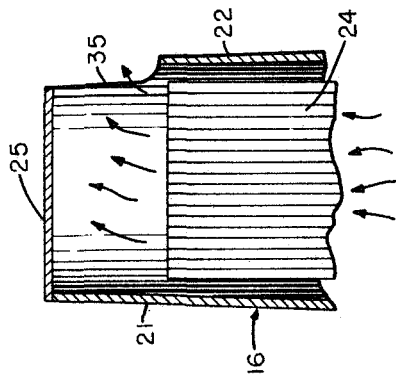

FIG. 7

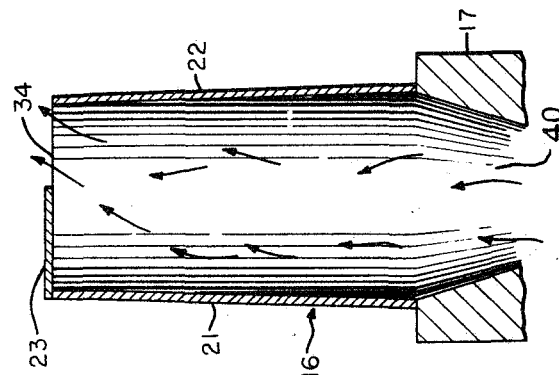

FIG. 6

INVENTORS
ANDRE J. MEYER JR
HOWARD F. GALVERT

BY

A. J. Meyer Jr.
ATTORNEY

Oct. 9, 1962

A. J. MEYER, JR., ET AL

3,057,597

MODIFICATION AND IMPROVEMENTS TO COOLED BLADES

Filed Aug. 20, 1959

5 Sheets-Sheet 5

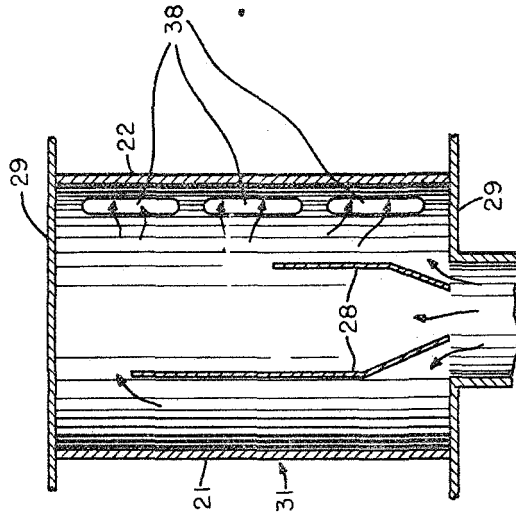

FIG. 10

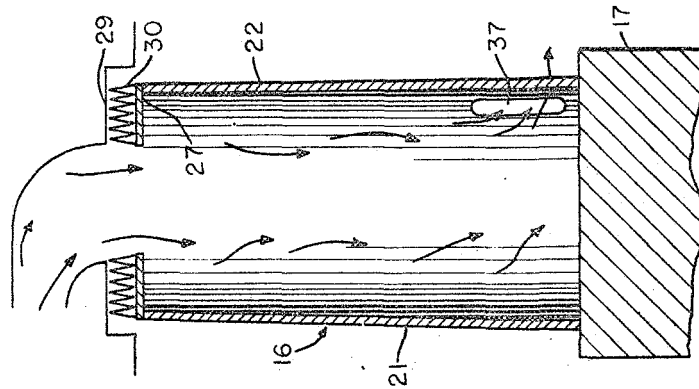

FIG. 9

INVENTORS
ANDRE J. MEYER JR
HOWARD F. CALVERT

BY

A. J. Meyer Jr.
ATTORNEY

1

3,057,597

**MODIFICATION AND IMPROVEMENTS
TO COOLED BLADES**

Andre J. Meyer, Jr., Newport News, Va., and Howard F. Calvert, Elyria, Ohio, assignors to the United States of America as represented by the Administrator of the National Aeronautics and Space Administration

Filed Aug. 20, 1959, Ser. No. 835,146

4 Claims. (Cl. 253—39.15)

(Granted under Title 35, U.S. Code (1952), sec. 266)

The invention described herein may be manufactured and used by or for the Government of the United States of America for governmental purposes without the payment of any royalties thereon or therefor.

The present invention relates to turbine rotor blading or stationary guide vanes and more particularly to air-cooled turbine blades and vanes wherein the cooling medium is exhausted into the main hot gas stream which propels the turbine.

Previous to the present invention, in air-cooled turbine configurations, the expended cooling air was exhausted along the entire chord at the rotor blade or guide vane tip. Experimental measurements and examination of blades after operation in a turbine show that the static pressure of the hot gases in the leading edge tip region of the airfoil section of the vane or blade is sometimes greater than the static supply pressure of the cooling medium. Under these conditions, hot gases actually flow into the leading edge section of the hollow airfoil section and the cooling air is prevented from reaching and cooling the blade material of the leading edge region. As a result, the hotter material along the blade leading edge fails prematurely, thus shortening the life of the turbine assembly.

An object of this invention is to cause the cooling medium to depart the blade in a region where the static pressure of the main hot gas stream is always less than the cooling medium supply pressure and to prevent hot gases from entering the airfoil section where the external pressure is greater than the internal coolant pressure.

Another object of the invention is the effective cooling of the entire leading edge of the rotor blades and the guide vanes in the turbine assembly.

A further object of the invention is to prevent the blade leading edge from failing prematurely due to inadequate cooling.

Still another object of the invention is the providing of a tip cap partially covering the normally open end of the rotor blade so as to let the cooling air to the leading edge discharge into a lower pressure region.

A still further object of the invention is the provision of internal-corrugation configurations which are designed either to have high internal surface area at the leading edge or to direct a maximum amount of cooling air to the leading edge.

Other objects and many attendant advantages of the present invention will be apparent from the following detailed description when taken together with the accompanying drawings in which:

FIG. 1 is an exploded pictorial view of components of a conventional uncapped semistrut corrugated air-cooled turbine blade.

FIG. 2 is a strut enveloped by a vertical corrugated member.

FIG. 3 is FIG. 2 covered with an outer shell that has a tip cap.

FIG. 4 is a strut enveloped by a slanted-corrugated member.

FIG. 5 is FIG. 4 covered with the outer shell that has a tip cap.

FIG. 6 is a cross-sectional view of a hollow airfoil shell in section mounted on a rotor showing the tip cap

2

in place and an opening for exhausting the cooling medium to the gas stream.

FIG. 7 is a cross-sectional view of an airfoil shell having internal vertical corrugated finning and an exhaust opening along the trailing edge.

FIG. 8 is a side view of a modification of the blade tip which has an exhaust opening adjacent to the trailing edge.

FIG. 9 is a cross-sectional view of a rotor blade shell wherein the cooling medium is brought in the shell through the tip and exhausted along the trailing edge near the blade base.

FIG. 10 is a cross-sectional view of a stationary guide vane with two internal partitions to direct the coolant and a plurality of exhaust openings.

Referring now to the drawings, wherein like reference characters designate like or corresponding parts throughout the several views, there is shown in FIG. 1 a conventional strut, generally designated 10, two inner shells 11, two vertical corrugations 12, and two outer shells 13. This is believed to be representative of the blades known in the art prior to applicant's invention.

Referring now to FIGS. 2 and 3, a vertical corrugated shell 14, the tip corners of which are removed so as to provide a small plenum chamber for the expended cooling air to exhaust into before moving through the blade tip, covers the strut 10 and inner shell 15 in FIG. 2, whereas a completed unit is shown in FIG. 3, having a rotor 17 and a tip cap 18 which is attached to or integrally formed with blade shell 16 by any appropriate means, leaving an exhaust opening 32.

Referring now to FIGS. 4 and 5, a slanted corrugated shell 19 covers the strut 10 and inner shell 15 in FIG. 4, whereas a completed unit is shown in FIG. 5, having a rotor 17 and a tip cap 20 integrally attached to and partially covering the outer blade shell 16, leaving an exhaust opening 33.

The slanted corrugation arrangement induces a maximum cooling flow rate to the leading edge. This is accomplished, as seen in FIGS. 4 and 5, by having the base of the corrugated member extending to the trailing edge so that no cooling air can enter there, thus the coolant is forced into the vacant space created in the region towards the leading edge and is directed toward the trailing edge by the corrugations.

In the normal operation of the turbine, the main hot gas flows from right to left in FIGS. 2 to 5 and from left to right in FIGS. 6 to 10. These hot gases would normally enter the turbine blade with high static pressures in the leading edge 21 region of the blade. As work is removed by the turbine rotor and/or pressure is converted into higher velocities in passing between or around the airfoil sections, the static pressure becomes quite low in the trailing edge 22 region. In a self-contained unit such as an aircraft jet or turbopropeller engine, the cooling air is also pumped by the main compressor that moves the main gas stream and therefore is never higher in pressure than the pressure entering the turbine. In fact, due to the arduous path of the cooling air up to and through the guide vanes or turbine blades, the cooling air pressure as it leaves the airfoil is appreciably less than the turbine inlet main stream gas pressure. Furthermore, to conserve on the amount of cooling air expended in cooling the turbine parts and thus to maintain good engine efficiency, the cooling air supply is usually throttled to still lower pressures. To provide good coolant flow to all internal parts of the hollow airfoil shells, the cooling air must all be exhausted at locations where the ambient pressure is less than the cooling air supply pressure. Furthermore, the high pressure inlet hot gases must be prevented from entering the lower pressure interior of the hollow shells. These ob-

jectives are accomplished by the tip caps and the exhaust openings on the trailing edge.

Referring now to FIGS. 6, 7, and 8 which are illustrative of three variations of possible tip cap and opening arrangements, in FIG. 6, the tip cap 23 extends from the leading edge 21 partially covering the hollow blade shell 16 which is attached to the rotor 17 and an exhaust opening 34 is provided on the blade tip extending to the trailing edge 22. An inlet aperture 40 is provided in the base of the blade for admitting the coolant thereto.

In FIG. 7, the blade shell 16 encloses vertical corrugations 24 and the tip cap 25 extends from the leading edge 21 to a point short of the trailing edge 22, the exhaust opening 35 comprising the corner formed by the tip cap 25 and the trailing edge 22. In FIG. 8, the tip cap 26 wholly covers the tip of the hollow blade shell 16 extending from the leading edge 21 to the trailing edge 22, while the exhaust opening 36 is situated on the hollow shell 16 adjacent the corner formed by the trailing edge 22 and the tip cap 26.

Referring now to FIG. 9, the cooling medium is caused to flow radially inward toward the axis of rotation from stationary piping through shroud 29. The sealing mechanism 30 may be any usable gas seal which effectively prevents the coolant from flowing directly into the main gas stream without first traversing the hollow blade 16 and also prevents hot gases from the main gas stream from flowing into the coolant passages. The tip cap 27 may be individual on each blade and straddled by the seal mechanism 30 or may be a continuous hoop affixed to the blade tips. The coolant, entering from the direction of the leading edge 21, and passing through the shell 16 may be discharged through openings anywhere along the trailing edge 22 or may traverse the full span of the blade and escape from the opening 37 shown positioned adjacent to the rotor 17.

Although in both FIGS. 8 and 9 only a single exhaust opening is shown, a multiplicity of openings along the trailing edge will accomplish the same purpose.

Referring finally to FIG. 10, the gas tight attachment of the hollow guide vane shell 31 to the two stationary shrouds 29 takes the place of a cap. The openings 38 along the trailing edge 22 of the shell are used to vent the expended cooling medium into the main fluid stream. Partitions 28 are inserted inside shell 31 to direct coolant to the remote corners of the shell before the coolant is vented to the main stream.

Obviously, many modifications and variations of the present invention are possible in the light of the above teachings. It is, therefore, to be understood that within the scope of the appended claims the invention may be practiced otherwise than as specifically described.

What is claimed is:

1. A cooled turbine blade having a leading edge and a trailing edge, said blade comprising: a base for operably connecting said blade to a turbine rotor; said base having at least one air inlet; a strut extending outward from said base; a corrugated member mounted on such strut and having slanted corrugations extending from said leading edge diagonally outward towards said trailing edge; an outer shell for encasing said corrugated member; said outer shell having an inner surface in engagement with

said corrugated member to form a plurality of air passages extending outwardly from said air inlet; a cap at the tip of said outer shell remote from said base and extending from said leading edge toward said trailing edge; said cap having an end edge spaced from said trailing edge to form an exhaust aperture adjacent said trailing edge; said corrugated member having an inner edge adjacent said base, an outer edge adjacent said cap, a forward edge directed toward the leading edge of said turbine blade, and a rearward edge directed toward said trailing edge; a portion of said corrugated member at the intersection of said outer edge and said forward edge being in engagement with the forwardmost portion of said inner surface of said outer shell immediately adjacent said leading edge, and a portion of said corrugated member at the intersection of said lower edge and said forward edge being spaced from said forwardmost portion of said inner surface to form a plenum chamber between said air inlet and said passages; and a portion of said corrugated member at the intersection of said lower edge and said rearward edge being in engagement with the rearwardmost portion of said inner surface of said outer shell immediately adjacent said trailing edge, and a portion of said corrugated member at the intersection of said outer edge and said trailing edge being spaced from said rearwardmost portion of said inner surface to form a plenum chamber between said passages and said exhaust aperture.

2. A cooled turbine blade having a leading edge and a trailing edge, said blade comprising: a base for operably connecting said blade to a turbine rotor; said base having at least one air inlet; a strut extending outward from said base; a corrugated member mounted on said strut; an outer shell for encasing said corrugated member; said outer shell having an inner surface in engagement with said corrugated member to form a plurality of air passages extending outwardly from said air inlet; a cap at the tip of said outer shell remote from said base and extending from said leading edge towards trailing edge; said cap having an end edge spaced from said trailing edge to form an exhaust aperture adjacent said trailing edge; a centrally disposed portion of said corrugated member extending to said exhaust aperture and an adjacent portion of said corrugated member being spaced from said cap to form a plenum chamber between a portion of said air passages and said exhaust aperture.

3. A cooled turbine blade, as in claim 2, wherein said corrugated member has corrugations extending radially outward from said base towards said exhaust aperture.

4. A cooled turbine blade, as in claim 2, wherein said corrugated member has slanted corrugations extending from said leading edge diagonally outward toward said trailing edge.

References Cited in the file of this patent

UNITED STATES PATENTS

2,514,105	Thomas	July 4, 1950
2,647,368	Triebnigg et al.	Aug. 4, 1953
2,750,147	Smith	June 12, 1956
2,888,243	Pollock	May 26, 1959