

December 1970

Brief 70-10700

# NASA TECH BRIEF



NASA Tech Briefs announce new technology derived from the U.S. space program. They are issued to encourage commercial application. Tech Briefs are available on a subscription basis from the National Technical Information Service, Springfield, Virginia 22151. Requests for individual copies or questions relating to the Tech Brief program may be directed to the Technology Utilization Division, NASA, Code UT, Washington, D.C. 20546.

## Lamp Modulator Provides Signal Magnitude Indication

A modulator for use with standard incandescent lamps provides a visible indication not only of the presence but also of the magnitude of an audio signal

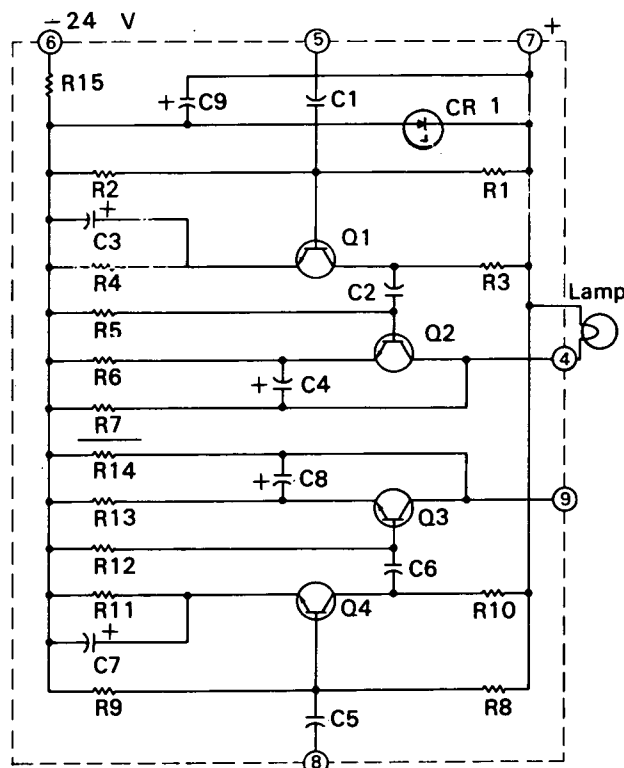

All resistors are  $1/4$  W  $\pm 5\%$  unless otherwise specified. Contacts 1, 2, 3, 10, 11, and 12 are omitted on printed circuit board.

Figure 1. Modulator's Circuit; Schematic

carrying voice or data. The device differs from previous models in that it can be made to reflect signal variations of up to 32 db. Other models operate through switch-type devices which apply full voltage

to the lamp, turning it either on or off, and poor or zero lamp modulation results.

The lamp-driver final stage of the modulator operates as follows: The operating point  $V_B$  (bottoming) of transistor Q2 (Fig. 1) is established at approximately 3.5 V. The amplifier Q-point is biased to operate at approximately 2.8 V (or close to  $V_B$ ) (Fig. 2).

The base of Q2 is anchored to the  $-20$ V supply only, thus restricting the transistor turn-on point ( $V_B$ ) to only the positive half of the operating signal. Polarized

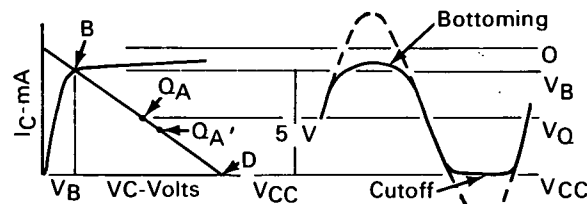

Figure 2. Load Line (Left) and Wave Form

capacitor C4, between the collector and emitter of Q2, charges to approximately 18.5 V—the steady-state voltage as generated by the keeper-current resistor R7. This capacitor must be large enough for the time constants to be greater than the total "on" time of Q2. Point  $V_B$  now controls the length of time during which C4 may discharge back through Q2, which means that the amplitude of the operating signal controls the "on" time. When the control signal turns Q2 "off," the capacitor recharges to the static conditions.

In effect, capacitor C4 attempts to integrate the on-off cycle and equate it to a mean dc voltage. The process is proportional until the maximum excursion—Q1 reaches  $V_{CC}$ , or the "cutoff" point—is reached (Fig. 2). Transistor Q1 is a standard amplification stage for providing adequate signalling to the lamp-driver stage. The circuit is insensitive to frequency.

(continued overleaf)

Another feature of the circuit is that it lengthens lamp life. Failure of a lamp filament is usually attributable to variations in filament resistance, causing localized hot spots. Consequent melting of the filament, or thermal stress at the points of stress, results in mechanical failure. The severity of the situation varies with the degree to which temperature changes from cold to hot and vice versa. By using a bypass resistor (R7 in Fig. 1) to keep the lamp filament near its operating point, the circuit reduces this temperature change and filament life is increased.

For example, the basic voltage on the No. 327 lamp in the circuit described is maintained at approximately 7 V, at which the filament is barely visible. The resistance at this level is 350 ohms. With full voltage on the lamp, the resistance is approximately 525 ohms. Consequently, the filament operates between 60% "on" (hot), rather than "off" and cold, and 100% "on" (hot).

**Note:**

Requests for further information may be directed to:  
Technology Utilization Officer  
Kennedy Space Center  
Code AD-PAT  
Kennedy Space Center, Florida 32899  
Reference: TSP70-10700

**Patent status:**

This invention is owned by NASA, and a patent application has been filed. Royalty-free nonexclusive licenses for its commercial use will be granted by NASA. Inquiries concerning license rights should be made to:

Patent Counsel  
Mail Code AD-PAT  
John F. Kennedy Space Center  
Kennedy Space Center, Florida 32899

Source: J. R. Zeman  
Kennedy Space Center  
(KSC-10565)