

December 1970

Brief 70-10692

NASA TECH BRIEF



NASA Tech Briefs announce new technology derived from the U.S. space program. They are issued to encourage commercial application. Tech Briefs are available on a subscription basis from the National Technical Information Service, Springfield, Virginia 22151. Requests for individual copies or questions relating to the Tech Brief program may be directed to the Technology Utilization Division, NASA, Code UT, Washington, D.C. 20546.

Resonant Systems for Dynamic Evaluation of Pressure Transducers

Methods for generating large amplitude, high frequency, dynamic pressures at high static pressures were studied with respect to possible use in calibrating pressure transducers at the amplitude, frequency, and pressure conditions stated. The most promising concept — simulating an inlet-modulated, gas-throttled siren type device (see fig.) — was chosen for analytical and experimental evaluation.

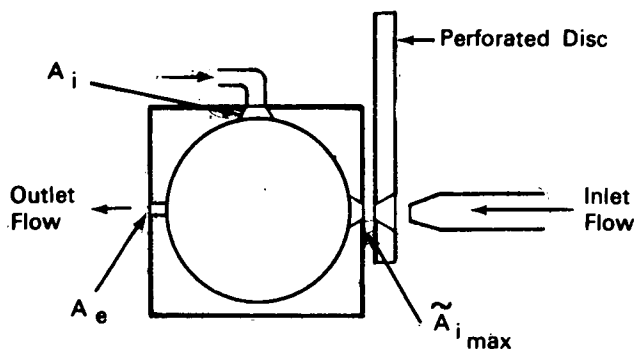

Schematic of Inlet-Modulated Sinusoidal Pressure Generator: A_e , Outlet-Throat Area; A_i , Inlet-Throat Area.

Fifty tests were conducted with a contrived inlet-modulated sinusoidal pressure generator (IM-SPG). The predicted generator performance was obtained, and the results confirmed that the concept is feasible and applicable to transducer evaluation.

However, the experiments that confirmed the calculations were made with a temporarily modified outlet-modulated sinusoidal pressure generator. Before the new technology can be made available, a true IM-SPG must be developed. The modified generator

employed produces only a limited portion of the necessary pressure-frequency range, does not have sufficient strength for the higher pressures desired, has improperly sized and shaped inlet and outlet passages, and lacks the necessary alignment and adjustment mechanisms.

It is recommended that the new IM-SPG be capable of operation at static or average-chamber pressures of from 1500 to 2000 psia, and that it be operable with either hydrogen or vacuum. Hydrogen has higher frequency and better wave-shape potentials because of its higher wave propagation speed — the speed of sound. For hydrogen operation, the IM-SPG should probably be encased in a gastight housing, and the entire system, including the gas reservoir, connecting lines, and ducting, should be covered with a forced-draft hood. A vacuum pump could be used with the housing and exhaust ducting to extend the calibrator's range, and the unit could be used to calibrate pressure transducers used in wind tunnels, jet engines, and fluidic applications.

Note:

The following documentation may be obtained from:

National Technical Information Service
Springfield, Virginia 22151
Single document price \$3.00
(or microfiche \$0.65)

Reference:

NASA-CR-72435 (N68-33640), Resonant Systems for Dynamic Transducer Evaluations

(continued overleaf)

Patent status:

No patent action is contemplated by NASA.

Source: R. E. Robinson and C. Y. Liu of
Battelle Memorial Institute
under contract to
NASA Headquarters
(HQN-10609)