

December 1970

Brief 70-10684

# NASA TECH BRIEF



NASA Tech Briefs announce new technology derived from the U.S. space program. They are issued to encourage commercial application. Tech Briefs are available on a subscription basis from the National Technical Information Service, Springfield, Virginia 22151. Requests for individual copies or questions relating to the Tech Brief program may be directed to the Technology Utilization Division, NASA, Code UT, Washington, D.C. 20546.

## Small, Efficient Power Supply for Xenon Lamps

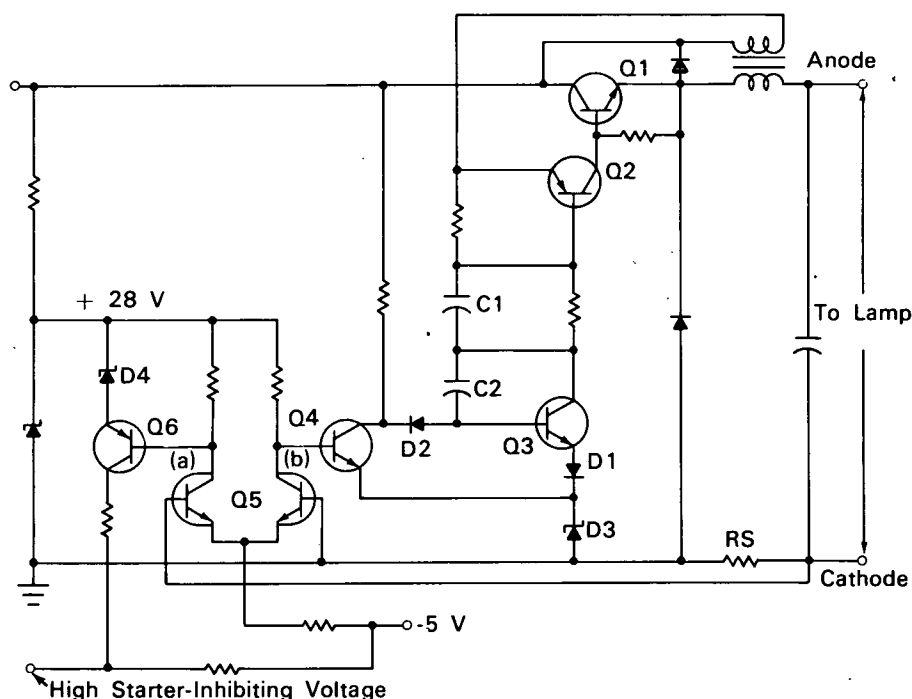

Figure 1. Schematic Diagram of Current Regulator

The unusual power demands of xenon lamps—constant voltage of 15 V when “on,” supply voltage of 40 V when “off,” and ionizing source of 25 kV pulse—can be met with a new power source, smaller and more efficient than previous models.

The device, which operates from 28 V dc, has four sections: a preregulator, a dc-to-dc converter, a current regulator, and a high-voltage starter. Although the individual sections are basically conventional, they each have specific characteristics that are somewhat unique.

The preregulator, for instance, requires fewer components than other models, and can operate at frequencies between 100 and 200 kHz with an efficiency of 90%. At high frequencies, smaller transformers and filter-capacitors can be used.

In the dc-to-dc converter, voltage feedback and current feedback are both used. The current feedback is applied from a separate transformer in series with the voltage-feedback transformer. The converter is free running with either feedback, but voltage feedback predominates at high loads and current feedback predom-

(continued overleaf)

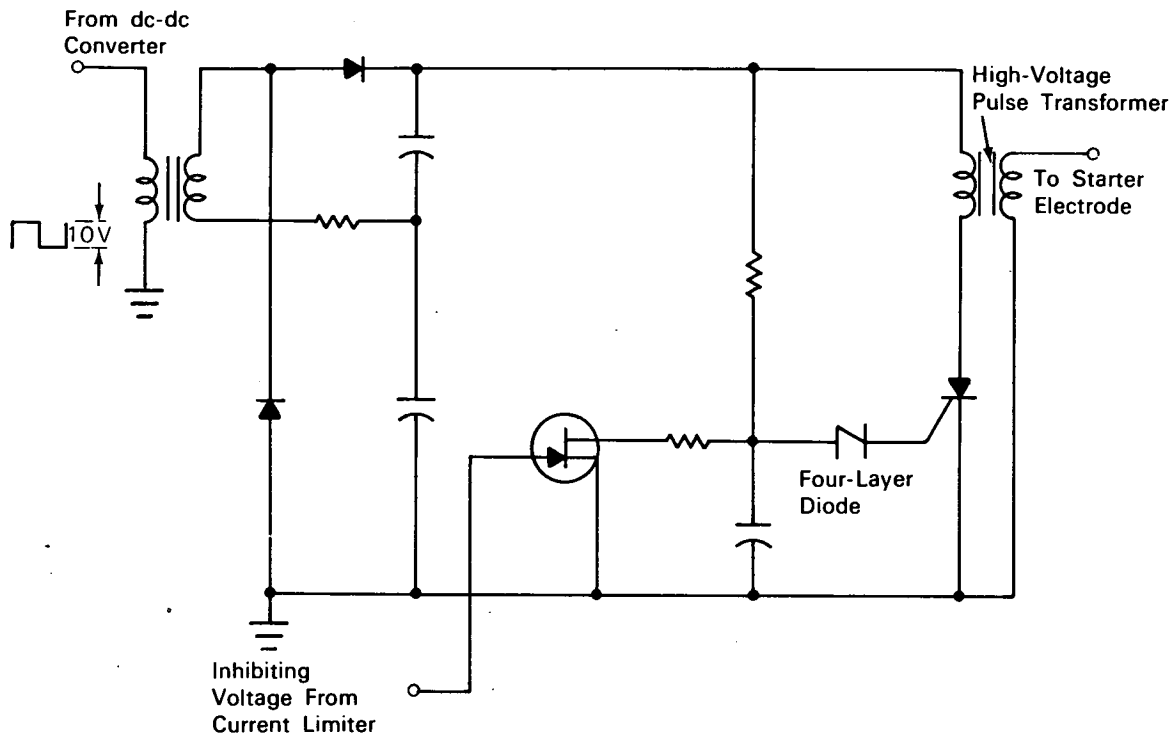

Figure 2. Schematic Diagram of Starter Circuit

inates at low loads. The unit provides 40 V for lamp operation and -5 V for control of the current regulator (Fig. 1), a ripple-type device.

Another lead from the transformer's -5 V winding provides a 10-V square wave to drive the high voltage starter. Adding secondary windings to the transformer can produce different voltages for different purposes.

The high-voltage lamp starter (Fig. 2) has a balanced voltage-doubling circuit driven by a 10-V peak-to-peak square wave supplied by the converter. The wave is transformed at 160 V peak-to-peak before the voltage is doubled. The resulting 160 V signal is stored across the voltage-doubling capacitors until the relaxation oscillator fires a silicon-controlled rectifier. The rectifier discharges the capacitor's energy through the primary of a high-voltage pulse transformer. The oscillator allows the voltage-doubling capacitors to charge and discharge until the xenon lamp lights. The starter-inhibiting circuit then provides a positive voltage

to the gate of an *N*-channel field-effect transistor. The transistor turns on and shorts the timing capacitor in the oscillator so that further firing of the rectifier is prevented.

**Note:**

Requests for further information may be directed to:

Technology Utilization Officer  
Manned Spacecraft Center, Code BM7  
Houston, Texas 77058  
Reference: TSP70-10684

**Patent status:**

No patent action is contemplated by NASA.

Source: J. E. Goodwin of  
Martin-Marietta Corp.  
under contract to  
Manned Spacecraft Center  
(MSC-13637)