

December 1970

Brief 70-10643

NASA TECH BRIEF



NASA Tech Briefs announce new technology derived from the U.S. space program. They are issued to encourage commercial application. Tech Briefs are available on a subscription basis from the National Technical Information Service, Springfield, Virginia 22151. Requests for individual copies or questions relating to the Tech Brief program may be directed to the Technology Utilization Division, NASA, Code UT, Washington, D.C. 20546.

Constant Current Load Matches Impedances of Electronic Components

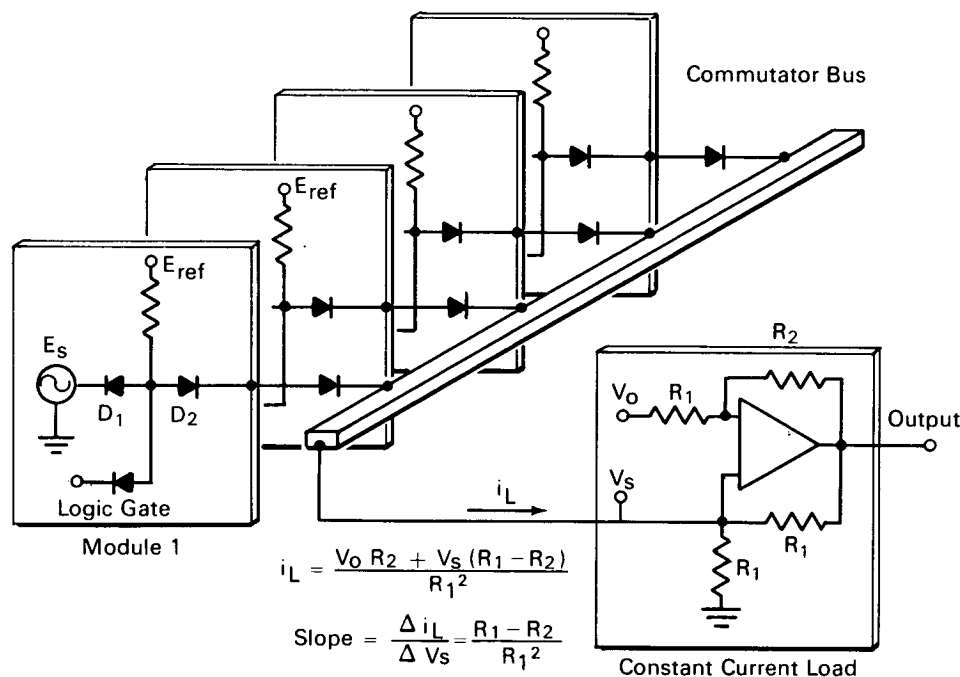

The problem:

In a time-sharing data transmission system, input signals from sensors and similar voltage sources are applied to a commutator bus. At the proper time, each signal is sampled and then stored for further processing. Accurate reproduction of the signal at the commutator output requires matching the impedances of circuit components. This technique is inadequate and time consuming when an accuracy of 5% is required.

The solution:

A constant current load with negative resistance characteristics actively compensates for impedance variations in the circuit components.

How it's done:

A representative commutator section is shown in the figure. When the signal input (E_s) to the commutator changes in a manner that unbalances the currents flowing through diodes D_1 and D_2 , the input impedance of the constant current load applied to the commutator bus also changes in the opposite direction, the voltage across the diodes changes correspondingly. The current-voltage balancing operation in effect maintains the internal impedance of the diodes at a constant value.

Notes:

1. The constant current load circuit can be used in simple telemetry systems such as annunciators,

(continued overleaf)

multistation burglar alarms and security surveillance equipment.

2. No additional documentation is available. Specific questions, however, may be directed to:

Technology Utilization Officer
Goddard Space Flight Center
Greenbelt, Maryland 20771
Reference: B70-10643

Patent status:

No patent action is contemplated by NASA.

Source: Richard Mills Alexander of
TRW Systems Group
under contract to
Goddard Space Flight Center
(GSC-10982)