



# AEC-NASA TECH BRIEF



AEC-NASA Tech Briefs announce new technology derived from the research and development program of the U.S. AEC or from AEC-NASA interagency efforts. They are issued to encourage commercial application. Tech Briefs are available on a subscription basis from the Clearinghouse for Federal Scientific and Technical Information, Springfield, Virginia 22151. Requests for individual copies or questions relating to the Tech Brief program may be directed to the Technology Utilization Division, NASA, Code UT, Washington, D.C. 20546.

## Redundant Electronic Circuit Provides Fail-Safe Control

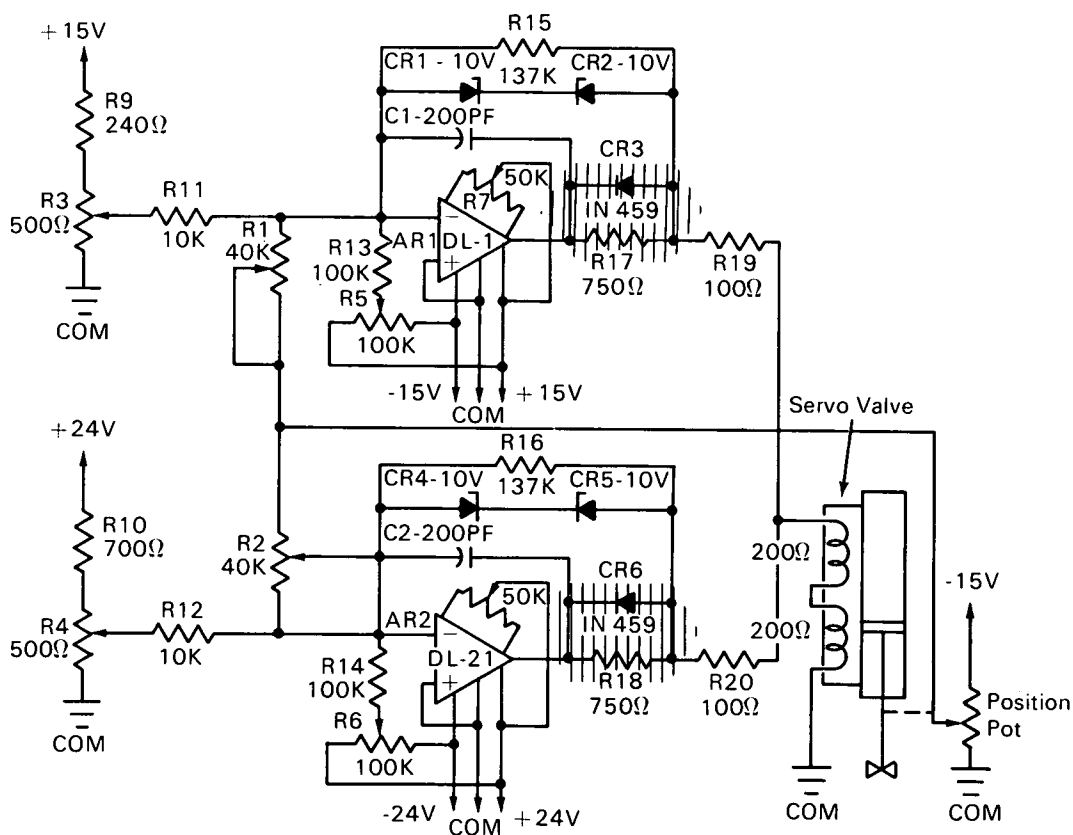

### The problem:

To design a reliable hydraulic valve controller that prevents closure of a valve when control circuits fail, and maintains valve control to a close tolerance for the more common modes of controller failure.

### The solution:

A circuit using dual control amplifiers and dual position demand potentiometers powered from separate

sources. The circuit configuration enables the output of one amplifier to override a failure in the other amplifier.

### How it's done:

The circuit shown in the figure operates in conjunction with a valve which opens upon loss of a signal, thus preventing the valve from closing when the control system fails. In operation, the resistor and

(continued overleaf)

diode combination, CR3/R17 and CR6/R18, provides two amplifiers with the capability of more "negative" output current than "positive" output current, regardless of the failure (negative and positive indicating current flow direction).

Referring to the amplifier gains in the figure, the controller will maintain the valve position within  $\pm 3\%$  of the demanded value for the following failures: (+) or (-) 24 or 15 V dc open or short; position demand from R3 and R4 open or short; and shorting of the (+) output transistor in the DL-21 or DL-1 amplifier.

The valve position error caused by one of the above failures is inversely proportional to the gain of the two control amplifiers. Therefore, if the valve gain is low, the gain of the control amplifiers may be made high, reducing the error. Conversely, a failed-closed valve system can be made by reversing any of the following: the excitation voltage connections to the valve position potentiometer; the leads to the servo valves; the excitation voltage to the two-position demand potentiometers; and diodes CR3 and CR6.

#### Notes:

1. Although the circuit accommodates the "worst" case (permanent short or open), it will also function in lesser failures such as partial opens or shorts.
2. Shorting of amplifier output to ground is a possibility (which will also be accommodated). However, this is not a "worst" case since in most circuits the "common" and "ground" are so connected that very little voltage potential can exist between them.
3. Inquiries may be directed to:  
Technology Utilization Officer  
AEC-NASA Space Nuclear Propulsion Office  
U.S. Atomic Energy Commission  
Washington, D.C. 20545  
Reference: B70-10565

#### Patent status:

No patent action is contemplated by AEC or NASA.  
Source: J. W. Archer of  
Aerojet-General Corp.  
under contract to  
Space Nuclear Propulsion Office  
(NUC-10389)