

NASA TECH BRIEF



NASA Tech Briefs announce new technology derived from the U.S. space program. They are issued to encourage commercial application. Tech Briefs are available on a subscription basis from the Clearinghouse for Federal Scientific and Technical Information, Springfield, Virginia 22151. Requests for individual copies or questions relating to the Tech Brief program may be directed to the Technology Utilization Division, NASA, Code UT, Washington, D.C. 20546.

Log Amplifier Instrument Measures Physiological Biopotentials Over Wide Dynamic Range

Logarithmic Input Stage

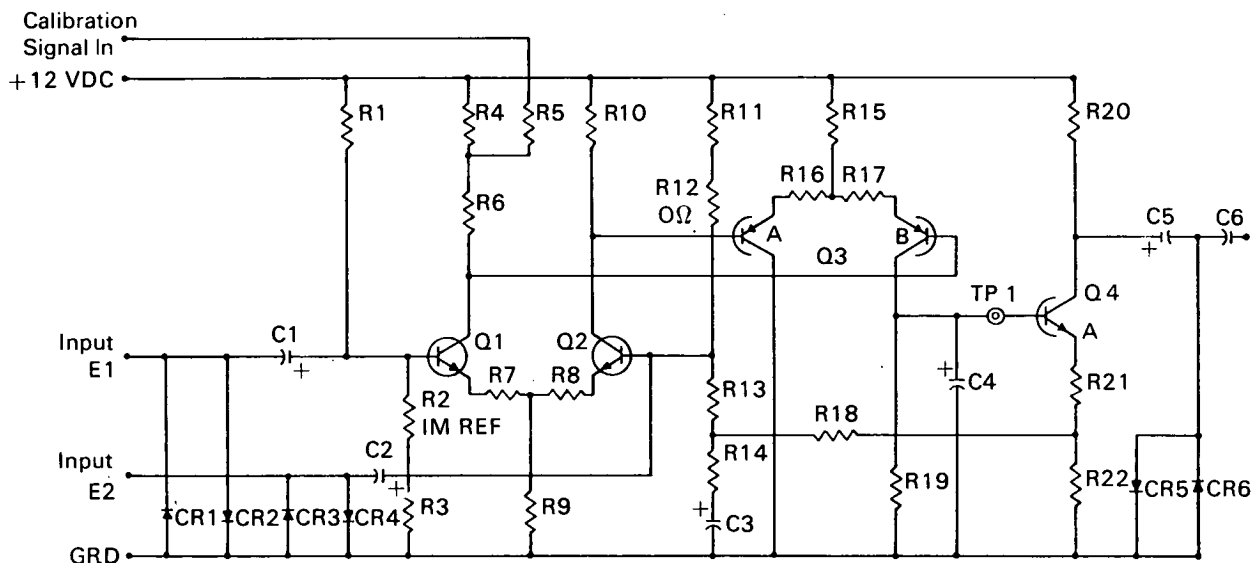

Signal Conditioner: Schematic

The problem:

The recording of biopotentials is difficult because their extreme dynamic range usually exceeds the capability of most recording devices; for example, 25 to 1 variations in amplitude are often found between the EEG potentials of animals which are awake and those which are asleep. Since these amplitude variations also exceed the input signal capabilities of most telemetry systems, a method was required to compress signal amplitudes without loss of resolution so that EEG signals from animals (asleep or awake) could be transmitted.

The solution:

Biopotential inputs are capacitively coupled to a miniature, low power, solid-state signal conditioner consisting of a two-stage differential preamplifier that has a low noise figure; the output of the preamplifier uses diodes to provide an overall gain which is nearly logarithmic.

How it's done:

The electronic circuitry developed for this application is shown in the figure. The differential-input stage is a conventional circuit employing two low-noise npn transistors, Q1 and Q2, with capacitively

(continued overleaf)

coupled inputs and appropriately placed diodes to suppress voltage overloads. The input resistance of the stage is 1 megohm. The input transistors are direct-coupled to a difference amplifier consisting of a matched pair of silicon pnp transistors, Q3. The output from the second differential stage, Q3B, is coupled directly to an npn amplifier, Q4A, which in turn provides dc feedback to the base of Q2 for Q-point stabilization of the overall amplifier, and feeds an amplified signal via a capacitor to the logarithmic diode signal compressors, CR5 and CR6.

Notes:

1. The response of the signal compressing diodes is not strictly logarithmic and is somewhat sensitive to changes in temperature. However, the pre-amplifier is intended for use where the absolute magnitude of a signal is not a critically important factor.

2. The use of low-noise npn transistors in complementary configuration with the matched pair pnp differential amplifier offers an improvement in noise and thermal stability over conventional circuits.
3. The upper limit of frequency response is determined by capacitor C4.
4. Requests for further information may be directed to:

Technology Utilization Officer
Ames Research Center
Moffett Field, California 94035
Reference: TSP70-10508

Patent status:

No patent action is contemplated by NASA.

Source: R. T. Kado of
University of California at Los Angeles
under contract to
Ames Research Center
(ARC-10032)