

October 1970

Brief 70-10469

NASA TECH BRIEF



NASA Tech Briefs announce new technology derived from the U.S. space program. They are issued to encourage commercial application. Tech Briefs are available on a subscription basis from the National Technical Information Service, Springfield, Virginia 22151. Requests for individual copies or questions relating to the Tech Brief program may be directed to the Technology Utilization Division, NASA, Code UT, Washington, D.C. 20546.

Control System for an Artificial Heart

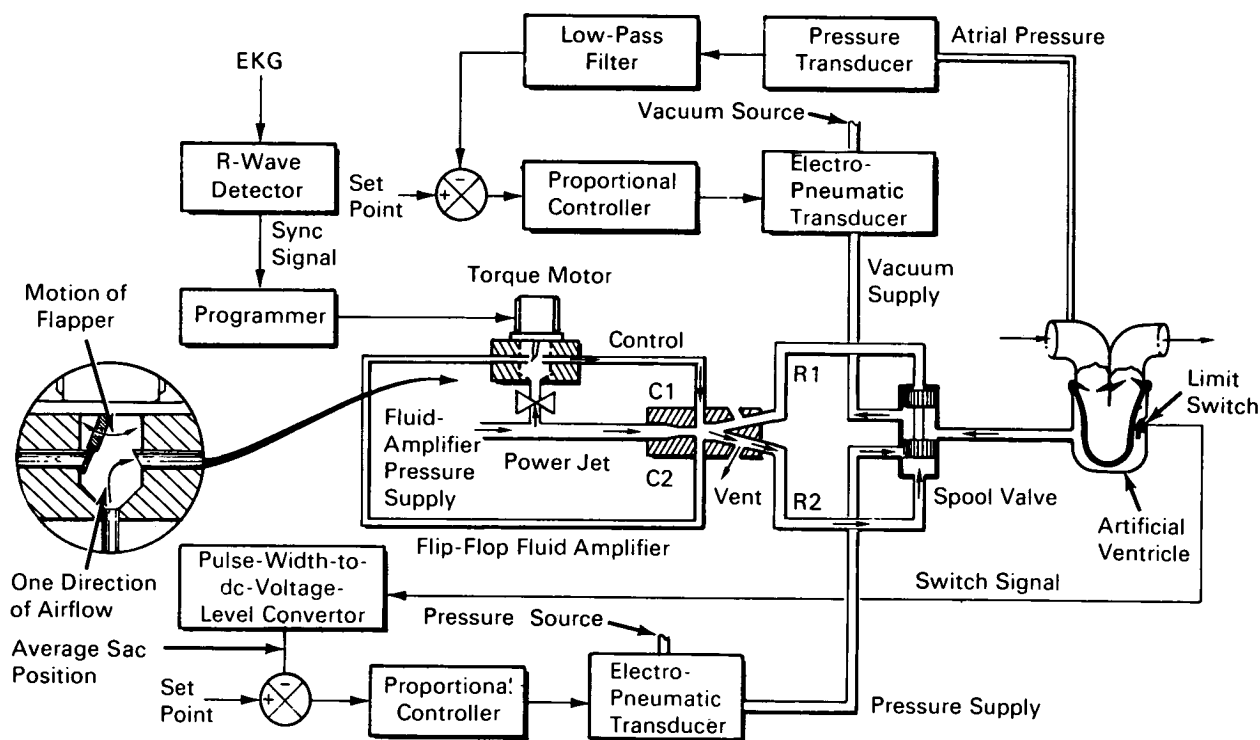

Control System for an Artificial Heart: Diagrammatic

The problem:

To drive a pneumatic, sac-type, heart-assistance blood pump with a controlled pulsatile pressure that makes the pump's rate of flow sensitive to venous (atrial) pressure, while the stroke is centered about a set operating point and the pump is synchronized with the natural heart.

The solution:

A combination of relatively inexpensive industrial pneumatic components produces a control system, for

a heart-assistance pump, having the greatest degree of simplicity consistent with the required degree of sophistication in control.

How it's done:

An R-wave detector (see fig.) senses the occurrence of the R-wave of an electrocardiogram and triggers a programmer. The programmer generates a pulse, adjustable in duration, with its leading edge adjustably delayed after the occurrence of the R-wave. The programmer drives a small torque motor that caps alter-

(continued overleaf)

nately the control ports of a fluid-amplifier. The output of the amplifier causes a spool valve to shuttle that alternately supplies gas pressure and vacuum to the blood pump to initiate the artificial heart's systolic and diastolic strokes.

The pump is controlled by manipulation of the levels of gas pressure and vacuum supplied to the spool valve over a period of several heartbeats; manipulation is by means of standard industrial process-controllers coupled to industrial electropneumatic transducers. Venous pressure is fed back to the vacuum-controller, thereby controlling the volume to which the sac fills. The output of a limit switch indicates distension of the sac. The signal from the limit switch is fed back to the pressure-controller to increase the volume of the ejection stroke until the sac barely reaches full distension at the end of filling.

All components but the R-wave detector and the programmer are standard industrial units; thus the system combines simplicity with versatility and reliability. Venous-pressure (atrial) and sac-position feedbacks provide the necessary sensitivity, of the blood's rate of flow, to venous pressure without ventricle overtravel. Thus the blood's average rate of flow can be changed to accommodate change in physiological demand, and to ensure a balance of blood volumes in pulmonary and systemic circulations.

By substitution of a free-running oscillator for the R-wave detector, and addition of a second output-pressure channel, the system can be used to control

a total-heart-replacement pump. The oscillator provides a variable pulse rate, and the two output-pressure channels provide pulsatile driving pressure for the left and right heart-replacement pumps.

Notes:

1. The following documentation may be obtained from:

Clearinghouse for Federal Scientific
and Technical Information
Springfield, Virginia 22151
Single document price \$3.00
(or microfiche \$0.65)

Reference:

NASA-TMX-1953 (N70-17953), Design and
Performance of a Heart Assist or Artificial
Heart Control System Using Industrial Pneu-
matic Components

2. Technical questions may be directed to:

Technology Utilization Officer
Lewis Research Center
21000 Brookpark Road
Cleveland, Ohio 44135
Reference: B70-10469

Patent status:

No patent action is contemplated by NASA.

Source: J.A. Webb, Jr., and V.D. Gebben
Lewis Research Center
(LEW-11057)