

September 1970

Brief 70-10452

# NASA TECH BRIEF



NASA Tech Briefs announce new technology derived from the U.S. space program. They are issued to encourage commercial application. Tech Briefs are available on a subscription basis from the Clearinghouse for Federal Scientific and Technical Information, Springfield, Virginia 22151. Requests for individual copies or questions relating to the Tech Brief program may be directed to the Technology Utilization Division, NASA, Code UT, Washington, D.C. 20546.

## Self Testing and Repairing Computer: A Concept

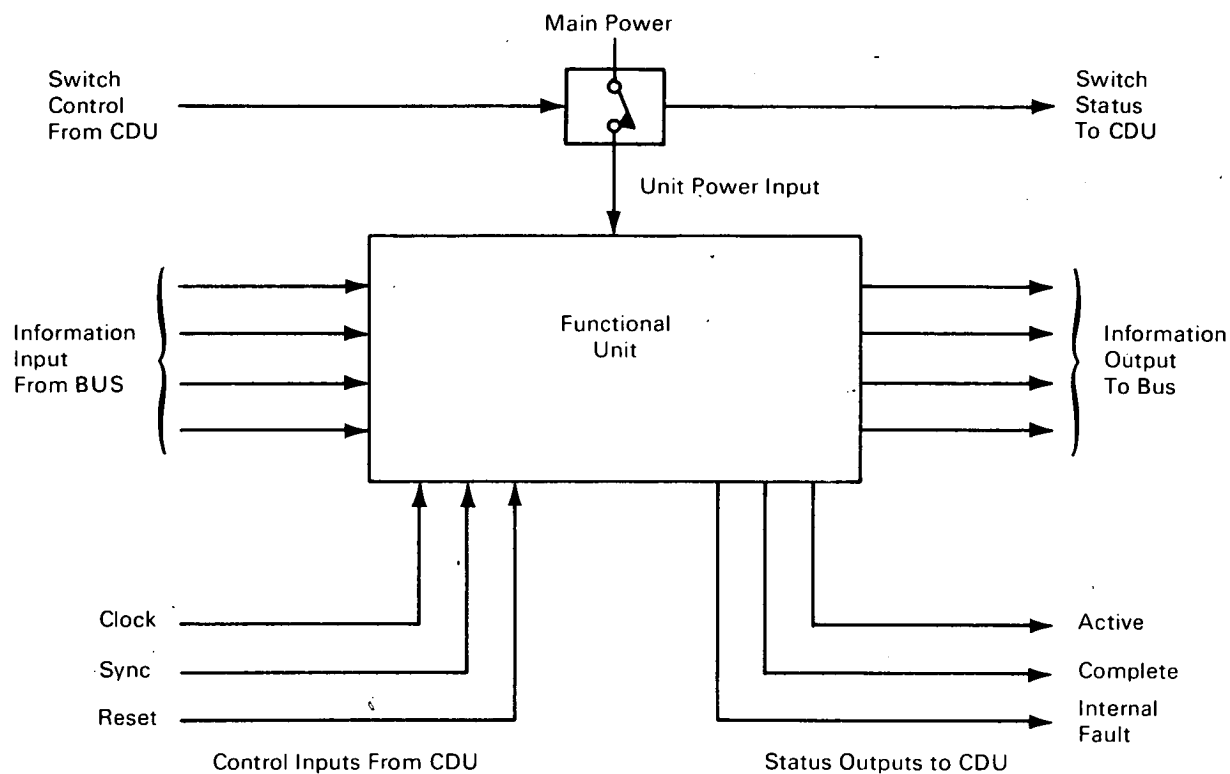

Conceptual Schematic

The immediate use for the prototype model of the self testing and repairing (STAR) computer is to investigate and reevaluate the concept of a computer that checks both the data and the instructions. Such a computer could be applied to process control computers where stopping the computer is not possible when a fault is noted, and would be valuable in airline reservation computer systems having many terminals, or in any real-time systems. The prototype of

this system now under construction is the only existing practical hardware in the computer field.

The STAR computer is made up of redundant modular function units. These function units, illustrated in the figure, are of several types and are connected to a diagnostic control unit. The most obviously needed types of function units required for some applications are (1) fixed store; (2) arithmetic; (3) memory; (4) input; and (5) output. Other units may be found neces-

(continued overleaf)

sary, for instance, system clock, or scientific data reducer units.

Fixed store function units will contain sequencing programs for guidance computations, and all emergency, diagnostic, and other internal procedures. Scientific data reduction programs may also be contained here. The program data (instructions) will be coded for detection of errors and failure. The redundancy will be in the form of reserve units; time redundancy (repeated readout) may also be used to determine if an error in a word is transient or due to component failure.

Arithmetic function units must have a provision to retain the error-detecting code in the results of arithmetical operations. Furthermore, an independent indication of which arithmetic operation has been performed is desirable with the result; in this manner, improper interpretation of the instruction by the arithmetic unit can be detected.

Memory function units are used for storage of intermediate results and other non-fixed information. Two units are likely to be used at once to avoid loss of information; an error correcting code is used also. An independent indication (to the Diagnostic Control Unit) of the address from which (or into which) information was delivered avoids errors due to incorrect address decoding.

Input function units are composed of various sensors and transducers and the radio receiver. Input data appears in digital form and is coded in an error detecting code. Such code may appear on shaft position digitizers. Validity check is available at each input. Spare input devices are available for self repair.

The radio receiver is expected to deliver coded information which can be checked for validity; a spare receiver is desirable.

Output function units are the various actuators and the radio transmitter. An independent feedback of the output information as delivered by the output units provides a check of their performance. Voting type redundancy of actuators is used. A spare radio transmitter is desirable.

The separation into function units allows most flexibility in assembling a complete STAR system; only the format of information must be retained. Thus many different systems may be put together from the set of units.

**Note:**

Requests for further information may be directed to:

Technology Utilization Officer  
NASA Pasadena Office  
4800 Oak Grove Drive  
Pasadena, California 91103  
Reference: B70-10452

**Patent status:**

Inquiries about obtaining rights for the commercial use of this invention may be made to NASA, Code GP, Washington, D.C. 20546.

Source: Algirdas A. Avizienis of  
Caltech/JPL  
under contract to  
NASA Pasadena Office  
(NPO-10567)