

September 1970

Brief 70-10409

# NASA TECH BRIEF



NASA Tech Briefs announce new technology derived from the U.S. space program. They are issued to encourage commercial application. Tech Briefs are available on a subscription basis from the Clearinghouse for Federal Scientific and Technical Information, Springfield, Virginia 22151. Requests for individual copies or questions relating to the Tech Brief program may be directed to the Technology Utilization Division, NASA, Code UT, Washington, D.C. 20546.

## Foolproof Quick-Release Locking Pin

A novel quick-release locking pin has been developed which can be withdrawn (to separate linked members) only when stress on the joint is negligible.

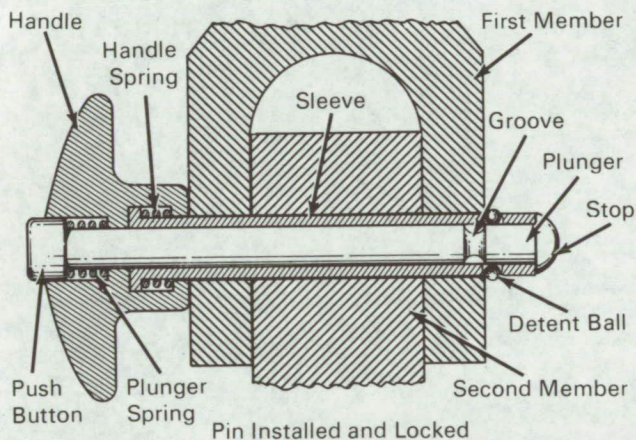

Pin Installed and Locked

The pin consists of a forward-pointing sleeve, with a spring-loaded sliding handle at its rear end, housing a sliding plunger that is urged backward (to its locking position) by a spring within the handle (see fig.). To a limited extent the plunger can slide forward against the plunger spring; the handle, backward against the handle spring. A groove near the front end of the plunger accommodates detent balls when the plunger is pushed forward by compression of its spring; when the plunger is released backward, the balls are forced outward into holes in the sleeve and so prevent withdrawal of the pin.

To install the pin, the plunger is pressed forward so that the balls fall into its groove; the pin is pressed into place, the plunger is released, and the balls lock the sleeve against withdrawal.

To withdraw the pin, the plunger is pressed forward to accommodate the locking balls and at the

same time pulls backward on the handle. If lateral stress on the pin is negligible the pin is withdrawn from the joint; if the stress is considerable, the handle spring is compressed and the plunger is forced backward by the handle so that the balls are returned to their locking position.

The allowable amount of stress on the joint at parting is adjusted by adjustment of the pressure required for compression of the handle spring. If the stresses on the joint are too great for the pin to be withdrawn in the normal manner, hammering the forward end of the plunger simply ensures that the plunger is in its rearward position, with the locking balls preventing withdrawal of the pin. A forged stop on the forward end of the plunger prevents the plunger from being driven backward.

### Note:

Requests for further information may be directed to:  
Technology Utilization Officer  
Marshall Space Flight Center  
Huntsville, Alabama 35812  
Reference: TSP70-10409

### Patent status:

This invention is owned by NASA, and a patent application has been filed. Royalty-free, nonexclusive licenses for its commercial use will be granted by NASA. Inquiries concerning license rights should be made to NASA, Code GP, Washington, D.C. 20546.

Source: T. E. Othman, E. P. Nelson  
and L. J. Zmuda of  
North American Rockwell Corp.  
under contract to  
Marshall Space Flight Center  
(MFS-18495)

Category 07