

September 1970

Brief 70-10400

NASA TECH BRIEF



NASA Tech Briefs announce new technology derived from the U.S. space program. They are issued to encourage commercial application. Tech Briefs are available on a subscription basis from the Clearinghouse for Federal Scientific and Technical Information, Springfield, Virginia 22151. Requests for individual copies or questions relating to the Tech Brief program may be directed to the Technology Utilization Division, NASA, Code UT, Washington, D.C. 20546.

Hydraulic Characteristics of Flow Through Miniature Slits

A study is reported (see documentation) of the gross hydraulic characteristics of the micro-orifices, rectangular in cross section, that are arrayed in close proximity across the face of an injector for liquid fuels; they have flow areas on the order of 10^{-4} to 10^{-5} in². The study attempted to determine the effects of geometry (dimensions and surface finish) and flow variables on the discharge coefficients and flow regimes of micro-orifices, as well as on the visible characteristics of the emerging liquid streams. The study was not all-embracing, but the key variables were identified and the parametric variations of interest to designers of injectors were developed.

Orifices tested (see fig.) had lengths (L) of nominally 0.05, 0.10, 0.20, and 1.0 in., heights (t) varying from 0.003 to 0.001 in., and a width (w) of about 0.100 in. Various surface finishes were tested, as well as various configurations of the entrance. The test fluids were distilled water, trichloroethylene, and commercial-grade n -hexane.

The discharge coefficient (c_d) proved to be sensitive to both the orifice's internal surface finish and the configuration of its entrance: smoother surfaces and rounded entrances increased c_d and so resulted in greater mass flow. Since the surface finish is related to the process by which the orifices are formed, their hydraulic characteristics may be strongly influenced by the various fabrication techniques. For a given cross section, surface finish, and entrance configuration of the orifice, c_d depends mainly on the ratio $L:t$ and is less affected by the Reynolds number (Re); low $L:t$ and high Re tend to maximize c_d .

Hydraulic flip, a form of flow instability, occurred when $L:t$ was less than about 40. The indication was that the highest values of c_d , for hydraulically stable orifices, ranged between 0.54 and 0.75 (depending

on Re) for the surface finishes and entrance conditions tested. These low values of c_d imply that rather high values of pressure drop may be entailed in maintenance of a given level of flow.

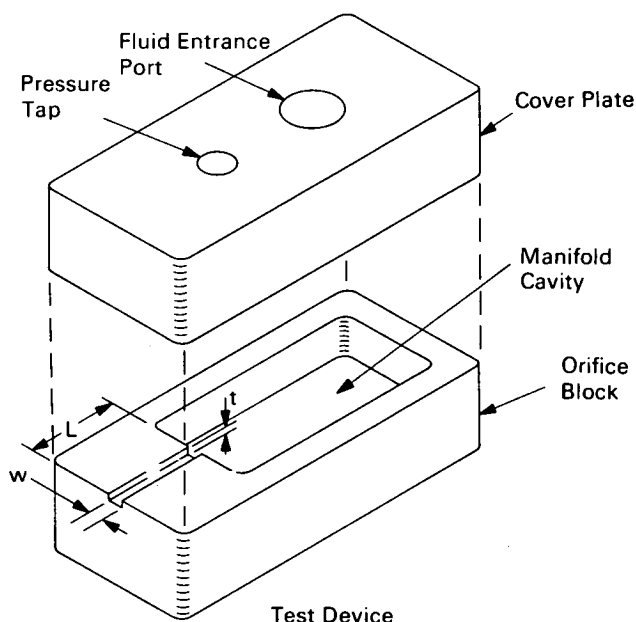

Over widely ranging conditions of operation the orifices studied showed flow that was transitional rather than laminar or turbulent. Reynolds numbers exceeding 2800 were necessary to ensure turbulent flow, whereas extremely low Re (<400) and long orifices were required for laminar flow. Thus, for most throttling operations, the relation between mass flow rate and pressure drop is expected to a somewhat involved function of Re and $L:t$.

The emerging streams proved to be highly stable, planar, and initially triangular. The apex angle of

(continued overleaf)

the triangle varied inversely with the Weber number, and the streams showed the inversions typical of sheets formed from rectangular or elliptic orifices. This difference in stream behavior (from streams from round orifices) suggests that greater care is needed in design of micro-orifice injectors (especially those involving stream impingement) than is usual for the common varieties of jet. A minimum t of 0.002 in. is recommended to prevent clogging and degradation of the stream.

Note:

The following documentation may be obtained from:

Clearinghouse for Federal Scientific
and Technical Information
Springfield, Virginia 22151
Single document price \$3.00
(or microfiche \$0.65)

Reference:

NASA-CR-105897 (N69-37690), The
Hydraulic Characteristics of Flow
Through Miniature Slot Orifices

Patent status:

Inquiries about obtaining rights for the commercial use of this invention may be made to NASA, Code GP, Washington, D.C. 20546.

Source: R.W. Riebling and W.B. Powell of
Caltech/JPL
under contract to
NASA Pasadena Office
(NPO-11354)