

September 1970

Brief 70-10392

NASA TECH BRIEF



NASA Tech Briefs announce new technology derived from the U.S. space program. They are issued to encourage commercial application. Tech Briefs are available on a subscription basis from the Clearinghouse for Federal Scientific and Technical Information, Springfield, Virginia 22151. Requests for individual copies or questions relating to the Tech Brief program may be directed to the Technology Utilization Division, NASA, Code UT, Washington, D.C. 20546.

Dual Current Readout for Precision Plating

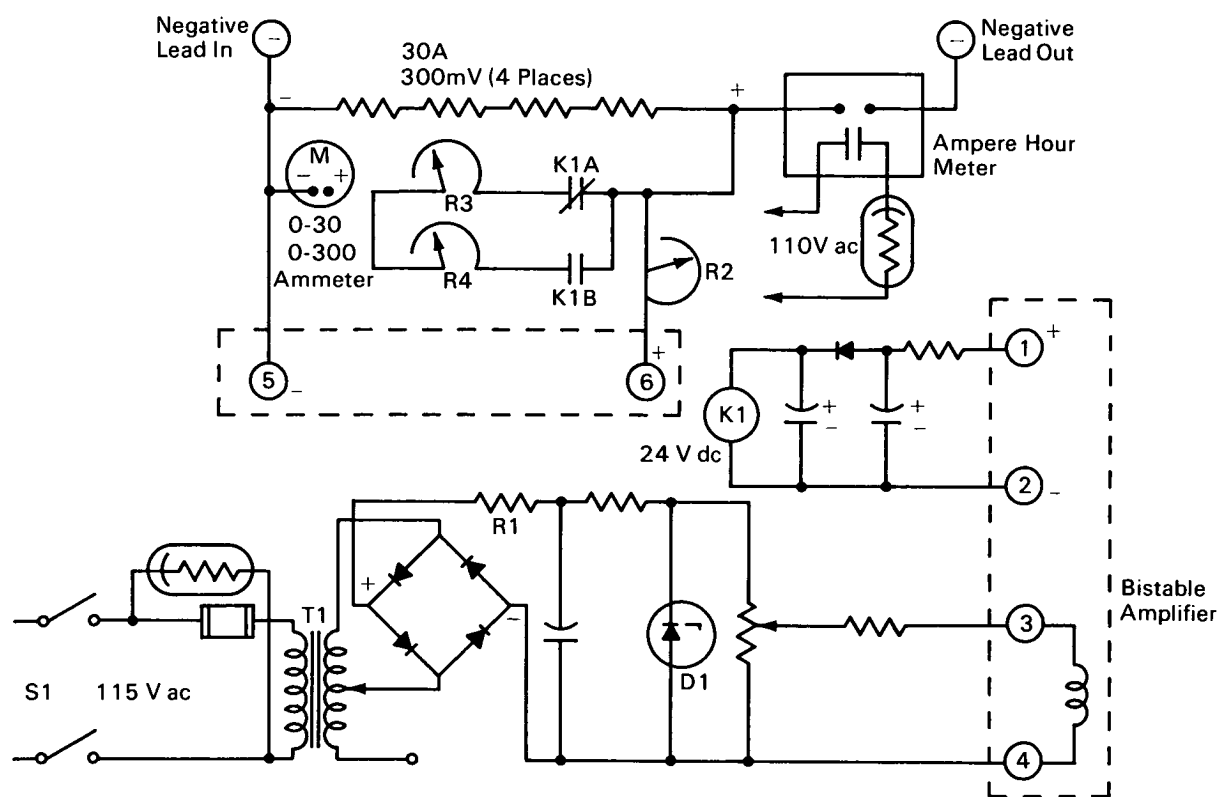

The problem:

In a precision electroplating system it is necessary to read precisely the current drawn by means of a single, dual scale (0 to 30 and 0 to 300) ammeter. In this application, the lower scale portion of the meter must be protected when the current drawn exceeds 30 amps.

The solution:

Use of a bistable amplifier to prevent damage in the low range circuitry by sensing the current and

automatically switching to the high range circuitry as the current rises above a preset level, in this case 30 amps.

How it's done:

In operation, 115 V ac is applied through switch S1 and is rectified in series with resistor R1 (See fig.). This voltage is filtered and regulated through zener diode D1 and applied to terminals 3 and 4 of the bistable amplifier. The negative lead-in is attached to the plating power supply (not shown), and the negative

(continued overleaf)

lead out is connected directly to the plating solution cathode. As current flows through the solution, it also flows through the four 30 amp, 300 mV shunts and the ampere-hour meter. Current flowing through the 0 to 30 amp circuit of the dual scale ammeter is controlled by the coil of relay K1. The two contacts K1A (normally closed) and K1B (normally open) are actuated as the plating current exceeds 30 amps. Resistor R2 controls the level of operation of the bistable amplifier by limiting the current flowing through terminals 5 and 6. As relay K1 is actuated through terminals 1 and 2 of the bistable amplifier, the dual scale ammeter is calibrated through resistors R3 and R4, which are (individually) in series with the meter. The ampere-hour meter provides current-time totals and may be reset by an external control knob.

Note:

No additional documentation is available. Specific questions, however, may be directed to:

Technology Utilization Officer
Manned Spacecraft Center, Code BM7
Houston, Texas 77058
Reference: B70-10392

Patent status:

No patent action is contemplated by NASA.

Source: W.F. Iceland of
North American Rockwell Corporation
under contract to
Manned Spacecraft Center
(MSC-15673)